

CONTENTS

Page

1. GENERAL DESCRIPTION 2

2. SPECIFICATIONS 3

3. RULES FOR SAFE OPERATION 4

4. OPERATION 5

 4.1. TURNING ON 5

 4.2. STABILISATION 6

 4.3. LISTENING 6

 4.4. DETECTION MODES 7

 4.4.1. PIG DETECT MODE 7

 4.4.2. PIG PASS MODE 8

 4.5. DETECTION DELAY 9

 4.5.1. DEBUG MODE 9

 4.5.2. LATCHED DETECTION 9

 4.5.3. LOG MEMORY 9

 4.6. SURVEY MODE 10

 4.7. SINGLE BUTTON MENU INTERFACE 11

 4.7.1. EXIT 11

 4.7.2. STATUS 11

 4.7.3. VIEW EVENTS 12

 4.7.4. DELETE ALL EVENTS 12

 4.7.5. SHUTDOWN 12

 4.7.6. MORE 12

 4.7.7. SET DETECTION DELAY / STABILISATION DELAY 12

 4.7.8. POWER MODE STD/LOW 12

 4.7.9. SET THRESHOLD 12

 4.7.10. SET DATE / TIME 13

 4.7.11. SET DETCT CRITERIA 13

 4.7.12. SET SURVEY TIME 13

 4.8. MOUNTING 14

 4.8.1. REMOTE SENSOR MOUNTING 14

 4.9. BATTERY REMOVAL 15

 4.10. EXTERNAL CONNECTIONS 16

 4.10.1. FORCE ON FUNCTION 16

 4.10.2. RELAY OUTPUT 17

 4.10.3. CURRENT LOOP OUTPUT 17

 4.11. RECOMMENDED MAGNET ARRANGEMENT 18

 4.12. MEMORY BACKUP 19

5. ROUTINE MAINTENANCE AND STORAGE 20

6. DISPOSAL 20

7. WARRANTY 20

8. ATEX / UKEX / IECEX APPENDIX 21

Revision	Updated By	Description of Update	Update Date
D	BG	CR-24-01-04-01: Content now applicable to all battery types and company logo update.	31/01/24

1. GENERAL DESCRIPTION

The IK Trax 4001D MAGSIG® is a fully ATEX, UKEX and IECEx certified, robust, non-intrusive magnetic pig signaller which detects, signals, and logs the passage of magnetic pigs at critical points along a pipeline both on land and offshore. Events are signalled as they occur via a 2.7" graphical display and high brightness LEDs positioned around the perimeter of the display.

The unit logs the time and date of up to 99 events. Logged events can be viewed locally on the graphical display, transmitted remotely over several optional interfaces, or downloaded using a laptop. The user can turn the unit ON and OFF as well as modify several settings using the single control button and intuitive menu system.

The unit can be quickly and easily attached to a pipeline using ratchet straps or steel banding. The unit is suitable for use on pipeline diameters up to 60" with wall thickness up to and in excess of 40mm (please contact IK Trax when wall thickness exceeds 25mm). Detection speed ranges from 0.01 to 20 metres per second. Window of detection is typically 0.5m either side of the unit. The detection capabilities vary depending on the background magnetic noise, pig speed, pipeline diameter, wall thickness and the quality of magnets fitted. For optimum performance it is recommended that pigs are fitted with magnets as described in Section 4.11 RECOMMENDED MAGNET ARRANGEMENT.

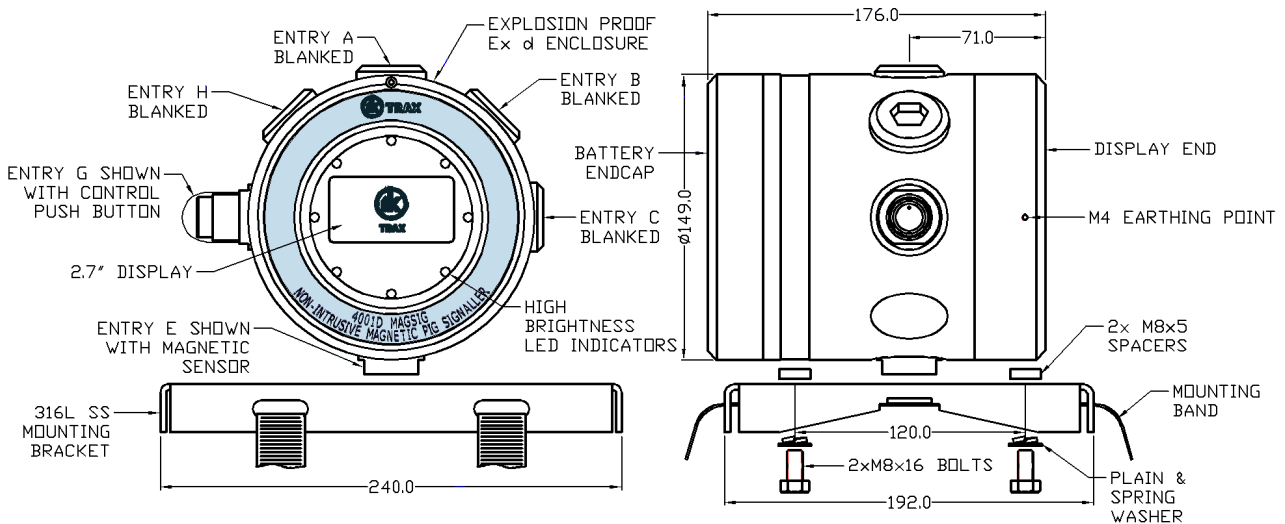

REMOTE SENSOR OPTION: The magnetic sensor can be supplied on a cable up to 10m long for use with buried pipelines or when access is limited. The protection concept for the remote sensor is intrinsically safe 'ia'.

POWER OPTIONS: The unit can be powered from internal batteries or from an external +24Vdc supply. Batteries where specified and provided can be fitted to provide backup power should the external supply fail. The unit uses 7x individual 'D' sized cells and is configured during manufacture for use with Alkaline (DURACELL ID1300) OR Lithium (SAFT LS33600) cells. The unit can only be configured for use with one cell type, to change the specified cell type, the unit must be returned to IK Trax.

ENTRY OPTIONS: The standard unit comes with 4x M20x1.5 entries with blanking elements installed. There is generous room inside the unit to make electrical connections without the need for additional junction boxes or enclosures. ATEX Exd adaptor options are available for 1/2" NPT and 3/4" NPT.

MATERIAL OPTIONS: The unit can be supplied with an epoxy coated Aluminium Alloy 6082-T6 or uncoated 316L Stainless Steel housing. Alternative coatings can be catered for.

TEMPERATURE RANGE OPTIONS: Ambient temperatures of -50°C can be accommodated by installing a heater within the electronics housing. Higher pipeline surface temperatures can be accommodated using a thermally insulated remote sensor.

2. SPECIFICATIONS

External supply	+21.6Vdc to +26.4Vdc, <1.0W
Temperature range using external supply (NO CELLS FITTED)	-40°C to +85°C
Battery/Battery type	7x DURACELL ID1300 Alkaline cells
Battery life in LISTENING/LOW POWER MODE at +20°C	160 days
Battery/Battery type	7x SAFT LS33600 Lithium cells
Battery life in LISTENING/LOW POWER MODE at +20°C	365 days
Temperature range while cells installed	Refer to Section 8 ATEX / UKEX / IECEx APPENDIX
Ingress Protection	IP66
ATEX/UKEX/IECEx code.....	II 1/2 G Ex db ia [ia Ga] IIC T4..T6X Gb
EU Type Examination Certificate Number.....	TRAC13ATEX0007X
UK Type Examination Certificate Number.....	EMA22UKEX0005X
IECEx Certificate Number	IECEx TRC 12.0017X
Weight in Aluminium.....	5.2kg
Weight in Stainless Steel	11kg
Pig Speed Range	0.01m/s to 20m/s

STANDARD OUTPUTS:

DPDT Relay Output (Volt Free Contacts).....	2A @ 30Vdc
Current Loop Output.....	15.0mA ±1.0mA (LISTENING) / 19.0mA ±1.0mA (DETECTION)

3. RULES FOR SAFE OPERATION

⚠ WARNING: The Special Conditions for Safe Use detailed in Section 8 ATEX / UKEX / IECEx APPENDIX of this manual must be observed at all times

⚠ WARNING: The purchaser of this equipment is responsible for the training and competence of operators and the manner in which it is used. This manual should be read through and understood before installation and commissioning so that the operator is familiar with the equipment. Contact IK Trax immediately should any difficulty arise in the use of this equipment.

⚠ CAUTION: If the signaller is to be placed in storage, always ensure that it is turned OFF and the batteries are removed and stored separately.

4. OPERATION

4.1. TURNING ON

To turn the unit on simply press and hold the control button until the COMPANY LOGO appears on the display and then release, this takes approximately 5 seconds. The unit may be configured to turn on automatically as per section 4.10.1 FORCE ON FUNCTION.

The COMPANY LOGO will be displayed for 5 seconds as shown by the COUNTDOWN INDICATOR located at the bottom left-hand side of the display.

A BATTERY LEVEL INDICATOR is shown at the bottom right-hand side of the display. Refer to Section 4.9 BATTERY REMOVAL for further information on battery voltages.

When the COUNTDOWN INDICATOR reaches zero, the CONTROL BUTTON is pressed, or any serial command is received, the next screen will appear.

The next screen shows the PRODUCT LOGO and firmware version at the very bottom of the screen in LNN format. When the COUNTDOWN INDICATOR reaches zero, or the CONTROL BUTTON is pressed, or any serial command is received, the next screen will appear the next screen will appear.

The next screen shows the current STATUS of all settings as per 4.7.2 STATUS. When the COUNTDOWN INDICATOR reaches zero, or the CONTROL BUTTON is pressed, or any serial command is received, the next screen will appear the unit will enter STABILISATION.

During STABILISATION the unit will not detect or log any magnetic events and the LEDs will flash every 5 seconds. When the STABILISATION counter reaches zero, the CONTROL BUTTON is pressed, or any serial command is received, the unit will start LISTENING for a magnetic event. See section 4.2 STABILISATION for more information.

While LISTENING, the screen will show the live DIFFERENCE flux readings at the top of the display and the current number of events logged. If previous EVENTS have been logged then a graphical representation of the DIFFERENCE signal of the most recent event along with the date and time of the event, will be shown. The LEDs will flash every 5 seconds. See section 4.3 LISTENING for more information.

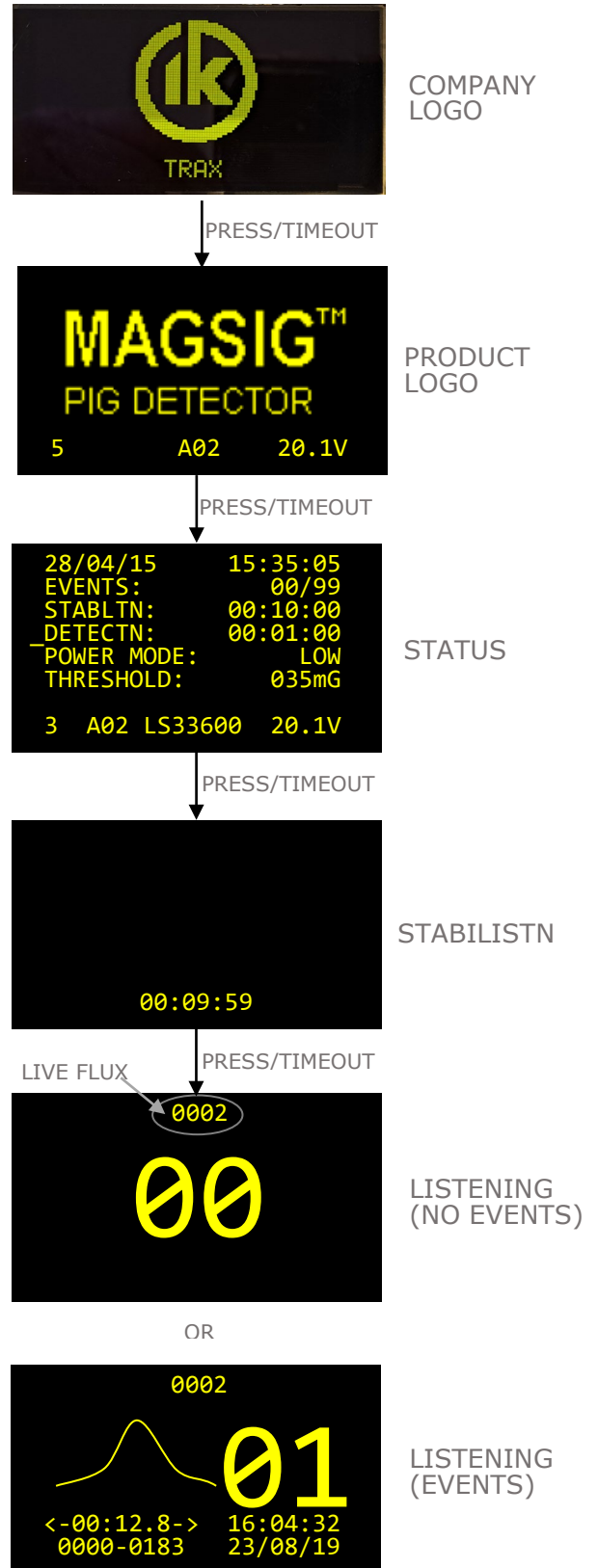

4.2. STABILISATION

The STABILISATION delay occurs at switch ON only. During the STABILISATION delay the unit will ignore all magnetic events. The LEDs will flash every 5 seconds and the relay and current loop outputs will be in the DETECTION state. The STABILISATION delay can be used during deployment to prevent any unwanted events from being logged due to movement of the unit in the earth's magnetic field and/or movement of nearby magnetic objects (such as vehicles).

The STABILISATION delay can be set to any value between 00:00:00 and 99:99:99 (in HH:MM:SS format) using the CONTROL BUTTON or via the serial link. During the STABILISATION delay a countdown timer is shown on the display and via the serial data link, once this timer reaches 00:00:00 the unit will start LISTENING. The STABILISATION delay can be bypassed by pressing the CONTROL BUTTON or by sending any serial command at any point during STABILISATION.

Remember that the STABILISATION delay occurs at switch ON only. If changes are made to the STABILISATION delay setting, then the unit should be turned OFF. The new STABILISATION delay will occur whenever the unit is next turned ON.

4.3. LISTENING

After STABILISATION the unit will display one of the screens shown opposite depending on if there have been any previous EVENTS.

If no previous events have been detected yet then this screen will show a large '00' with no graph, date or time. The LEDs above the display will flash every 30 seconds.

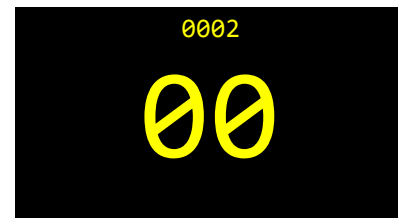

LISTENING - NO EVENTS

If previous events have been detected then this screen will show a graphical representation of that event, large digit event number, time and date of the event, time span of the event and the peak difference. The example shows EVENT #01 occurred at 13:56:42 on 28/04/11, lasted for 12.8 seconds with a peak difference of 183mGauss.

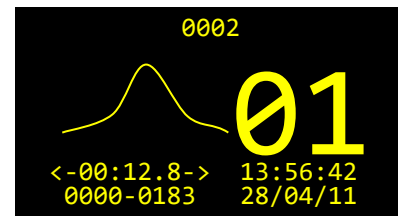

LISTENING - WITH EVENTS

The four digits at the top of these screens show the live DIFFERENCE flux readings, in a magnetically quiet environment this number can be expected to flicker between 0000 and 0005.

While LISTENING the unit continually takes RAW flux readings which are FILTERED and the DIFFERENCE between the RAW and FILTERED values calculated. If the DIFFERENCE ever exceeds the THRESHOLD setting, then the unit enters DETECTION MODE. While LISTENING, the LEDs around the display will flash every 5 seconds and the relay and current loop outputs will be in the LISTENING state. There are 4x things that may cause this screen to change:

MAGNETIC EVENT – If a DIFFERENCE flux reading greater than the THRESHOLD value is detected while the unit is LISTENING, the unit will enter DETECTION mode as per 4.4 DETECTION MODE.

LOW POWER MODE – If LOW POWER MODE has been selected, the display will turn OFF after 15 seconds to preserve the batteries. A single press of the CONTROL BUTTON will force the display ON for the next 15 seconds. If a magnetic event is detected, then the display will come on as normal and show the DETECTION screen.

CONTROL BUTTON – Pressing the CONTROL BUTTON while the display is ON will enter the DISPLAY MENU interface which is described in section 4.7 SINGLE BUTTON MENU INTERFACE of this manual.

SERIAL COMMAND – If a serial command is received via the serial data link then it will be processed before the unit continues LISTENING.

4.4. DETECTION MODES

There are two possible detection modes described in the following sections depending on how the unit has been configured as per 4.7.11 SET DETCT CRITERIA.

4.4.1. PIG DETECT MODE

PIG DETECT mode is used to detect the presence of pigs but does not attempt to confirm they have passed the signaller. This can be useful at pig launchers or receivers where depending on signaller position the pig may only move away from or approach a signaller without actually passing it.

PIG DETECT mode is basically the same as 4.4.2 PIG PASS MODE with a 0% peak.

The signaller waits in LISTENING mode.

PIG APPROACH is displayed as soon as the flux reading crosses the threshold. The time and date when the threshold was crossed is shown. The flux reading continues to show live flux readings.

PIG DETECTED is displayed and the DETECTION DELAY starts (see 4.5 DETECTION DELAY) as soon as the flux reading has stopped increasing for more than 0.5 seconds. The peak flux reading and time and date when the peak occurred is shown.

During the DETECTION DELAY the unit will keep logging readings until the internal event buffer is full or the CONTROL BUTTON is pressed. At this point the EVENT NN (event number) will appear on the screen. No other EVENTS will be detected or signalled during the DETECTION DELAY.

On completion of the DETECTION DELAY or if the DETECTION DELAY is bypassed by pressing the CONTROL BUTTON the signaller returns to LISTENING mode.

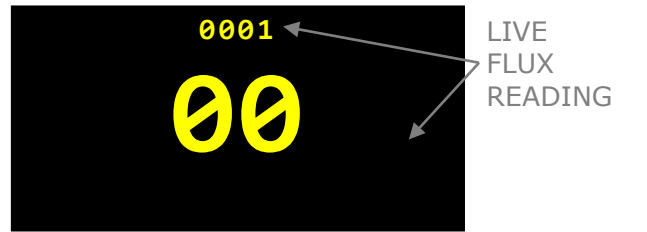

THRESHOLD MET



PEAK READING

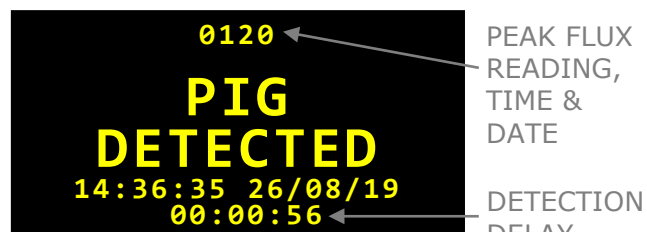

BUFFER FULL

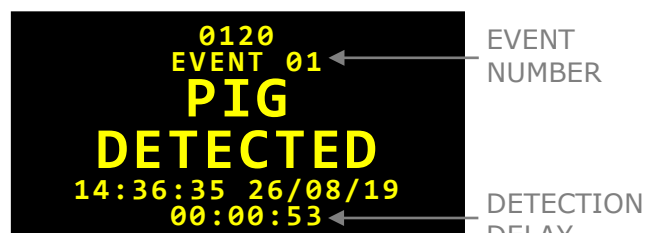

4.4.2. PIG PASS MODE

PIG PASS mode is used to confirm pigs have passed the signaller. This is achieved by only signalling PIG PASSED if the flux readings drop by a user selectable percentage below the peak reading (5%, 10%, 25% or 50%). See 4.7.11 SET DETCT CRITERIA.

The signaller waits in LISTENING mode.

PIG APPROACH is displayed as soon as the flux reading crosses the threshold. The time and date when the threshold was crossed is shown. The flux reading continues to show live flux readings.

PIG PASSED is displayed and the DETECTION DELAY starts (see 4.5 DETECTION DELAY) as soon as the flux reading has dropped by the defined amount below the peak reading. The peak flux reading and time and date when the peak occurred is shown.

During the DETECTION DELAY the unit will keep logging readings until the internal event buffer is full or the CONTROL BUTTON is pressed. At this point the EVENT NN (event number) will appear on the screen. No other EVENTS will be detected or signalled during the DETECTION DELAY.

On completion of the DETECTION DELAY or if the DETECTION DELAY is bypassed by pressing the CONTROL BUTTON the signaller returns to LISTENING mode.

If PIG APPROACH is displayed but the pig stops near the signaller without causing a sufficient peak then the signaller shall return to LISTENING 3 minutes and 24 seconds after displaying PIG APPROACH without displaying PIG PASSED or starting the DETECTION DELAY. This will be logged as an event however no event will be signalled via the LEDs or any other interface such as relays or current loop.

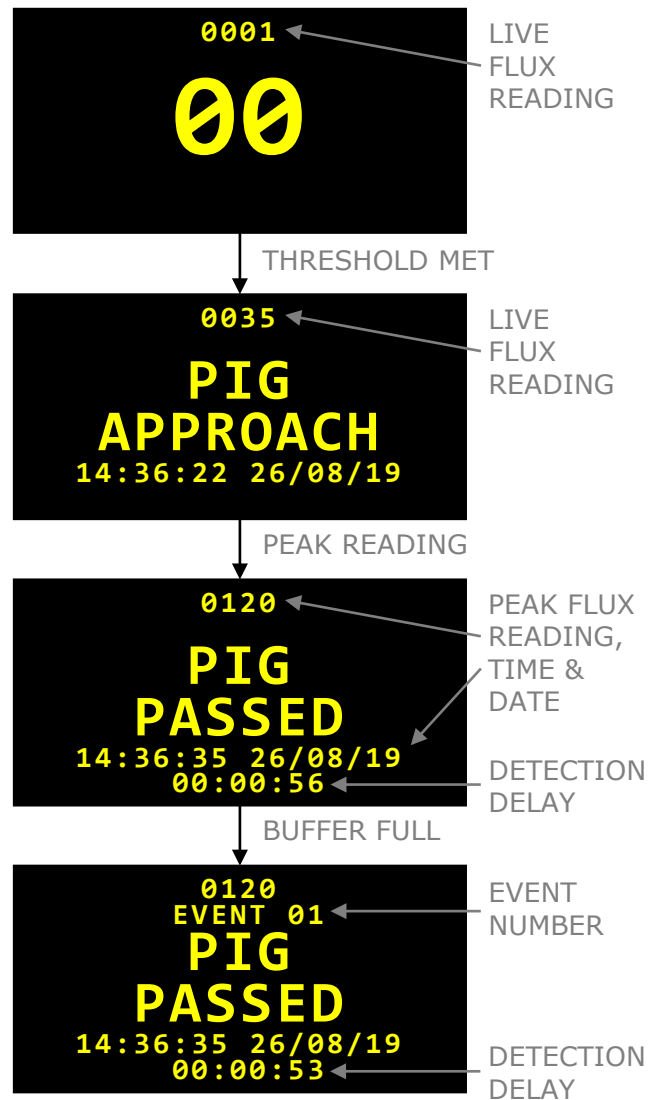

4.5. DETECTION DELAY

The DETECTION DELAY controls how long the unit will signal an event for. Usually, it will be configured to give the magnetic pig enough time to get out of range of the sensor after it has been detected to avoid re-trigger. When dealing with pig trains, the expected pig speed and separation should be used to configure a suitable value for the DETECTION delay such that the unit will not detect the same pig twice but will enter LISTENING mode in time to detect the next pig.

The DETECTION delay can be set to any value between 00:00:01 and 98:99:99 (in Hours:Minutes:Seconds format) using the CONTROL BUTTON or the 4000SD CONFIG software.

During the DETECTION DELAY the three LEDs above the display will flash every 1 second.

The DETECTION DELAY can be bypassed by pressing the CONTROL BUTTON.

4.5.1. DEBUG MODE

If the DETECTION DELAY is set to 00:00:00 then the 4001D works in DEBUG mode, DEBUG MODE text is shown on-screen and NO detections will be signalled. DEBUG MODE is exited by setting the DETECTION DELAY to 00:00:01 – 98:99:99. If DEBUG MODE is set when in LOW POWER MODE, the signaller will exit LOW POWER MODE, which must be re-entered manually once DEBUG MODE is exited.

See also 4.6 SURVEY MODE.

4.5.2. LATCHED DETECTION

If the DETECTION DELAY HH (hours) field is set to 99 then when an EVENT occurs the 4001D will latch indefinitely in DETECTION mode showing the EVENT information and flashing the 3x LEDs every 1 second. To begin LISTENING again the CONTROL BUTTON must be pressed.

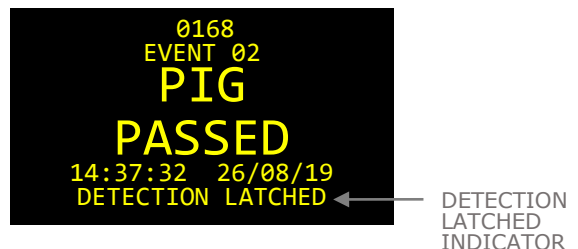

In LP mode, the screen will remain on until LISTENING resumes.

4.5.3. LOG MEMORY

The 4001D is capable of logging up to 99 events with date, time, and the peak DIFFERENCE flux reading. Each log entry is capable of recording between 6.4 seconds and 3 minutes 24.8 seconds of data depending on pig speed / detection time.

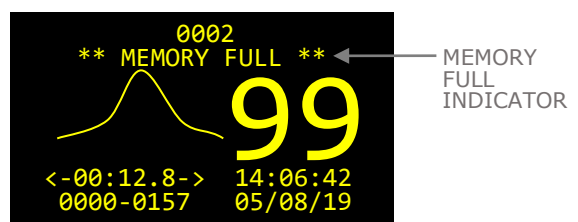

Once 99 events have been logged a MEMORY FULL warning will appear indicating that the logger memory is full, this warning will appear on PIG APPROACH, PIG PASSED and PIG DETECTED screens.

Subsequent events will be signalled but no data will be logged. Because of this behaviour it is important to erase all events prior to each deployment to ensure that the full memory space is available.

4.6. SURVEY MODE

SURVEY MODE is an extended DEBUG MODE which gives a live, scrolling, graphical representation of the gauss readings received. The signaller remains in LISTENING mode and does not signal magnetic events. SURVEY MODE can be very useful for determining the magnetic signature of a pig however is not normally used for regular pig signalling.

SURVEY MODE is entered via the POWER menu on MENU level 2. The DETECTION DELAY is not altered in SURVEY MODE and is retained when SURVEY MODE is exited.

The vertical amplitude scale defaults to 80mG and increases automatically but must be manually rescaled to the default. The horizontal time scale default to an update every 0.1s and can be set using the SET SURVEY TIME item in MENU level 3, this setting is not remembered when the unit is switched off. Oldest data is always deleted.

The MENU can be entered with a single button press of <1 second. The graph can be reset (cleared) by pressing the CONTROL BUTTON for more than 1 second and less than 5 seconds. The data displayed can be logged by pressing the CONTROL BUTTON for 5 seconds, the DEBUG status changes to LOGGED and the CONTROL BUTTON can be released. Note that the displayed data logged is at the point where the PIG STATUS changes to LOGGED and not when the CONTROL BUTTON was pressed. The logged data can be viewed using the VIEW EVENT function in MENU level 1.

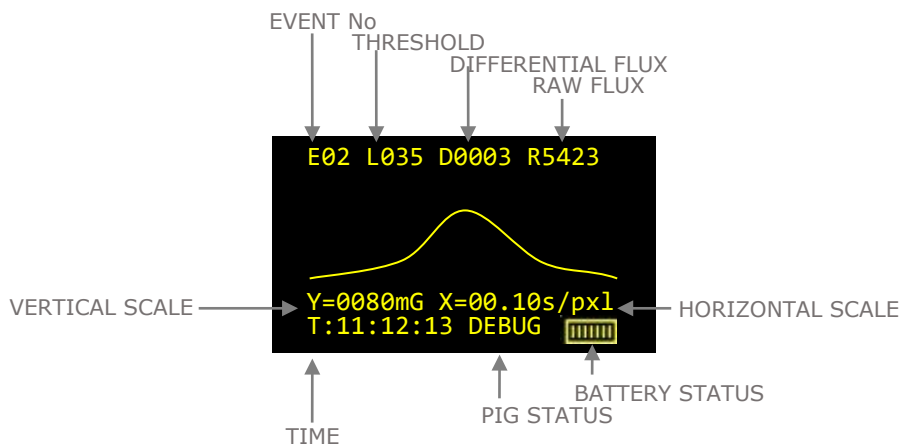

This setting can be very useful for determining the magnetic signature of a pig. However, this mode should never be used for regular pig signalling. See also 4.5.1 DEBUG MODE.

4.7. SINGLE BUTTON MENU INTERFACE

While LISTENING, the control button can be pressed to enter the menu interface. While in the menu interface, the unit will ignore all magnetic disturbances including PIG passages. From the menus the user can configure several parameters which are discussed in this section.

While in the menu system, every time the user presses the control button the CURSOR will move down one line and the COUNTDOWN INDICATOR will be reset to 5. Once the CURSOR is pointing at the desired item the user simply allows the COUNTDOWN INDICATOR to reach 0 and the selected item will be executed. This simple behaviour is used throughout the menu interface to modify settings and interact with the unit.

To modify parameters, simply follow the instructions provided on screen. All parameters are incremented by pressing the CONTROL BUTTON until they are at the desired value then allowing the COUNTDOWN INDICATOR to reach 0.

If you do not wish to modify a parameter, then simply allow the COUNTDOWN INDICATOR to reach 0 without operating the CONTROL BUTTON. The menu system is designed so that the unit will always start LISTENING again if the CONTROL BUTTON is left released for a long enough time.

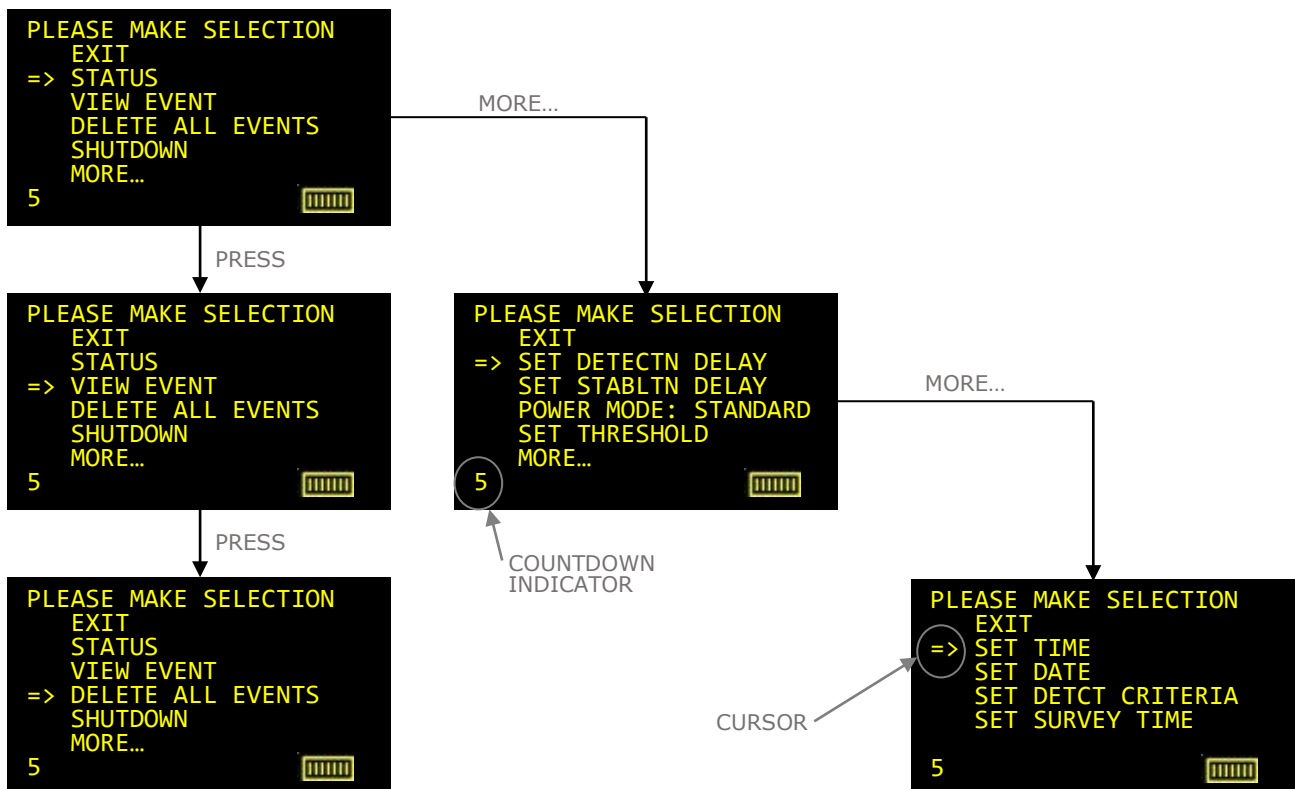

4.7.1. EXIT

The first item on every page of the menu system is EXIT. If EXIT is selected, then the unit will exit the menu system and resume LISTENING.

4.7.2. STATUS

The STATUS screen is also shown at switch ON. It shows the Date, Time and Number of logged events, Stabilisation delay, Detection delay, Power Mode, Threshold setting, Battery type and Firmware version. The STATUS screen can be halted by pressing and holding the control button. Ensure all of these settings are at the required values.

4.7.3. VIEW EVENTS

Selecting this item will allow the user to cycle through all logged EVENTS from newest to oldest. The peak DIFFERENCE flux reading, EVENT number, and EVENT date and time are shown. Pressing the CONTROL BUTTON will cycle to the next event. The CONTROL BUTTON can be held to pause at any event. If the COUNTDOWN INDICATOR reaches 0 then the unit will exit and resume LISTENING.

4.7.4. DELETE ALL EVENTS

Selecting this item will delete all logged EVENT data. A warning screen will be displayed saying “*WARNING* PRESS TO ERASE ALL EVENTS”. To erase all events, press the CONTROL BUTTON before the COUNTDOWN INDICATOR reaches 0. To cancel the erase simply allow the COUNTDOWN INDICATOR to reach 0 without pressing the CONTROL BUTTON.

4.7.5. SHUTDOWN

Selecting this item switches off the unit. The unit has memory backup and will remember all settings (such as the DELAYS and THRESHOLD) until next time the unit is switched on. It is imperative that the unit is turned off using this command rather than simply disconnecting the battery to allow any memory storage processes to terminate prior to turning OFF.

See section 4.10.1 FORCE ON FUNCTION if using the force on function.

See section 4.12 MEMORY BACKUP for memory backup limitations.

4.7.6. MORE...

Selecting this item shows the next page of the menu system.

4.7.7. SET DETECTION DELAY / STABILISATION DELAY

Refer to section 4.5 DETECTION DELAY for more information regarding the DETECTION delay.

Refer to section 4.2 STABILISATION for more information regarding the STABILISATION delay.

4.7.8. POWER MODE STD/LOW

Toggles between LOW POWER MODE, STANDARD MODE and SURVEY MODE

In STANDARD POWER MODE the display will be ON all of the time. In LOW POWER MODE the display will turn OFF after 10 seconds to preserve battery life. The detection routines are identical in each mode.

In SURVEY MODE, a graphical representation of the magnetic signal is shown along with DIFFERENCE and RAW magnetic readings. This is a DEBUG mode and hence no DETECTION will occur.

4.7.9. SET THRESHOLD

ADJUSTING THIS PARAMETER WITHOUT FIRST CONSULTING IK Trax MAY CAUSE THE UNIT TO MISS PIG PASSAGES OR GIVE FALSE DETECTIONS. Selecting this item allows the THRESHOLD level to be configured to control the sensitivity of the unit. The standard THRESHOLD value is 035mG. Reducing the THRESHOLD value increases the sensitivity. The THRESHOLD can be configured to any value between 005mG and 999mG. See section 4.3 LISTENING for a brief explanation of the THRESHOLD value.

4.7.10. SET DATE / TIME

Selecting these items allows the date and time to be adjusted. Ensure that a valid time is entered in 24hour, HH:MM:SS format and a valid date in DD/MM/YY format.

4.7.11. SET DETCT CRITERIA

This menu item allows selection of the DETECTION CRITERIA with the available options shown. The asterisk "*" shows the current selection.

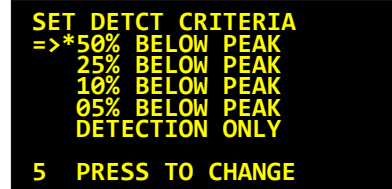

The % BELOW PEAK options allow for pig passage detection as per 4.4.2 PIG PASS MODE.

The DETECTION ONLY option allows for general pig detection as per 4.4.1 PIG DETECT MODE.

4.7.12. SET SURVEY TIME

This menu option is only available in SURVEY MODE. It allows the graph timescale to be set, default is 0.1s/pixel giving a visible graph time of 12.8 seconds. This value is not retained on power cycle.

Selectable options are:

Visible graph time	Time per pixel
00:06.4	50mS
00:12.8	100mS
00:25.6	200mS
00:51.2	400mS
01:42.4	800mS
03:24.8	1.6S

4.8. MOUNTING

Normally the unit is used to confirm whether or not a pig has passed a known point of interest in a pipeline such as a bend or valve. Ideally the unit should be mounted approximately 5m after the point of interest. If the unit is mounted too close, then it may detect the pig before the pig has passed safely through the point of interest.

If it is not possible to mount the signaller 5m after the point of interest then a test run would be advantageous to determine the typical strength of magnetic signal coming from the pig and then the detection range can be reduced accordingly by increasing the THRESHOLD value referring to section 4.7.9 SET THRESHOLD of this manual.

The unit is supplied with a mounting plate. The unit can be mounted with a ratchet strap or steel band. For either method follow the procedure below, using the manufacturer's instructions which are provided with this equipment:

1. The Special Conditions for Safe Use detailed in section 8 ATEX / UKEX / IECEx APPENDIX of this manual must be observed at all times.
2. Ensure the mounting plate is securely fitted to the housing with 2x M8x16 bolts. An M8x5mm thick washer should be sandwiched between the housing and the mounting plate.
3. Temporarily place the unit at the chosen location to ensure that the unit sits in place without rocking.
4. Loop the band through the slots provided as shown and then gradually tighten the band until the unit is held firmly. Do not use excessive force.
5. If equipotential bonding or earthing is required, then the M4 threads around the perimeter of the display endcap may be used.

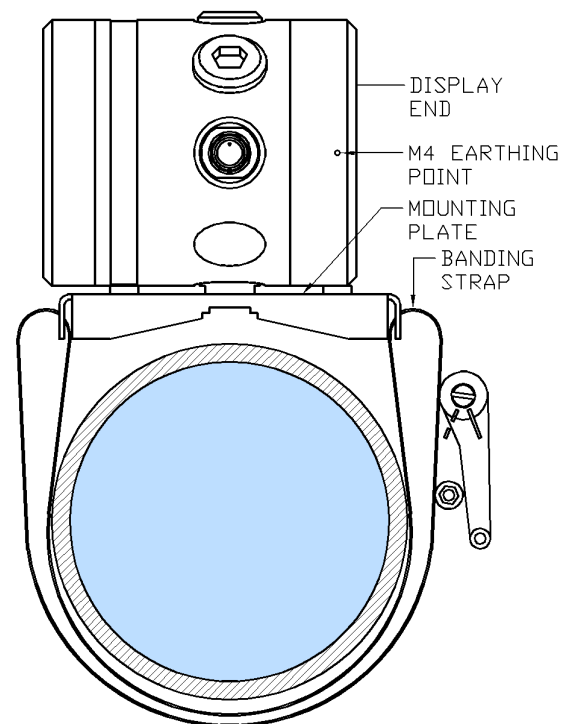

4.8.1. REMOTE SENSOR MOUNTING

If fitted, the remote sensor is mounted using the supplied mounting plate and a ratchet strap or steel band similar to the main housing

Loop the band through the slots provided on the remote sensor mounting plate as shown and then gradually tighten the band until the sensor is held firmly. Do not use excessive force.

If the pipeline surface temperature is expected to exceed +85°C then a thermally insulating pad will be supplied fitted to the remote sensor. In this case the sensor must be fitted on the lower half of the pipeline as shown to minimise convection heating.

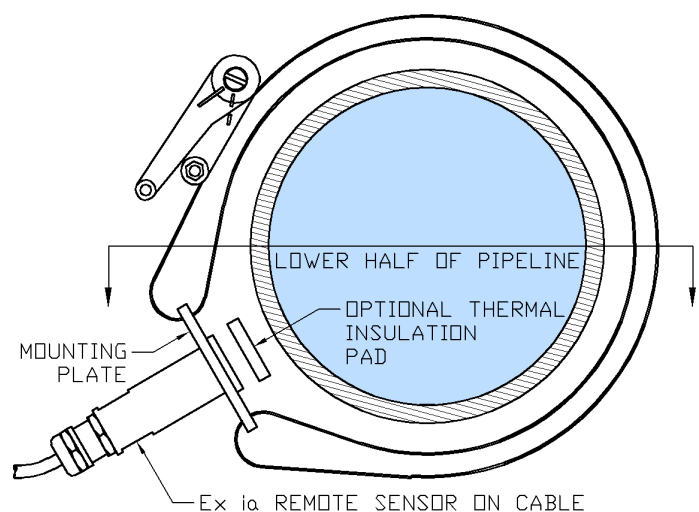

4.9. BATTERY REMOVAL

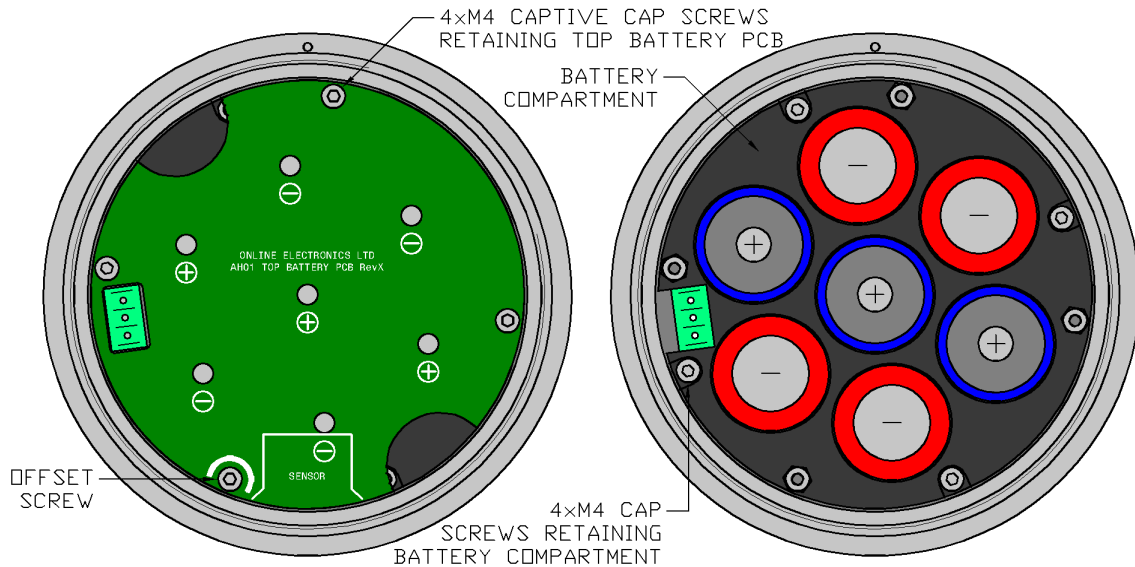

The unit will shut down when the battery voltage reaches 6.5V ALKALINE or 17.0V LITHIUM. To replace the batteries, follow the steps below:

1. The Special Conditions for Safe Use detailed in section 8 ATEX / UKEX / IECEx APPENDIX of this manual must be observed at all times. Only the cell type stated should be installed in the unit.
2. Using a 3mm AF allen key loosen the M4 locking screw located at the 12 o'clock position on the BATTERY ENDCAP 6x full turns.
3. Carefully unscrew the BATTERY ENDCAP while being prepared to take the weight when it disengages. There are 4x unthreaded holes around the perimeter of the endcap which may be used should leverage be required.
4. The TOP BATTERY PCB should now be visible as shown above. Using a 3mm AF allen key loosen all 4x captive cap screws 3x full turns each before fully disengaging all screws and removing the TOP BATTERY PCB.
5. Replace all batteries confirming that their polarity matches the information shown on the TOP BATTERY PCB. The negative end of each battery should be in contact with a spring. **REPLACE ALL BATTERIES AT THE SAME TIME. NEVER USE A MIX OF NEW AND USED BATTERIES. NEVER USE A MIX OF BATTERIES FROM DIFFERENT BATCHES. ENSURE THAT THE CORRECT BATTERY TYPE IS USED. ALWAYS OBSERVE CORRECT BATTERY POLARITY.**
6. Replace the TOP BATTERY PCB checking that the orientation is correct. Note that one of the retaining screws is offset to prevent incorrect orientation.
7. Replace the BATTERY ENDCAP and gently hand tighten. Do not use tools or over tighten otherwise the endcap will be difficult to remove. The M4 locking screw should be located close to the 12 o'clock position when the endcap is fully engaged, there should still be a small gap (<0.5mm) between the endcap and housing.
8. Using a 3mm AF allen key gently tighten the M4 locking screw. Do not over tighten, very little torque is required to lock the endcap in place.

4.10. EXTERNAL CONNECTIONS

To access external connections, follow the steps below:

1. The Special Conditions for Safe Use detailed in section 8 ATEX / UKEX / IECEx APPENDIX of this manual must be observed at all times.
2. Remove the BATTERY ENDCAP, TOP BATTERY PCB, and batteries as described in section 4.9 BATTERY REMOVAL of this manual.
3. Using a 3mm AF allen key, remove the 4xM4 cap screws which hold the battery compartment in place and remove the BATTERY COMPARTMENT to reveal the external connections as shown.

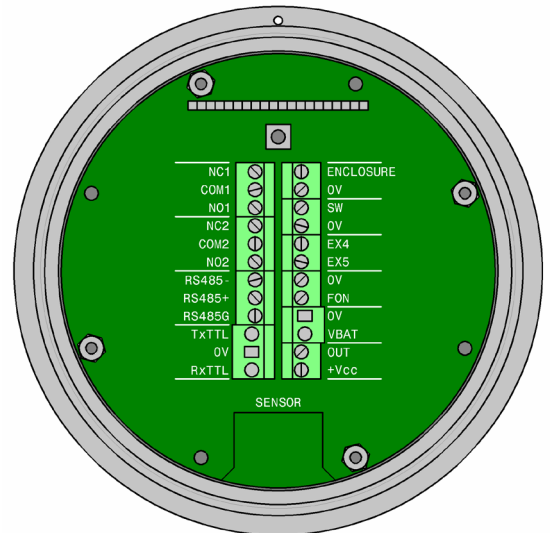

All connections are made using 5.08mm pitch removable terminal blocks which can accept up to 2.5mm² (14AWG) wire size. All connections must be made using suitable crimp ferrules. Connections are clearly labelled on the PCB and have the following functions:

- NC1/2 - Normally Closed contact of relay 1 and 2 respectively (see section 4.10.2)
- COM1/2 - Common contact of relay 1 and 2 respectively (see section 4.10.2)
- NO1/2 - Normally Open contact of relay 1 and 2 respectively (see section 4.10.2)
- RS485- - Do not use these connections
- RS485+ - Do not use these connections
- RS485G - Do not use these connections
- TxTTL - Do not use these connections
- RxTTL - Do not use these connections
- ENCL - Connected to enclosure (may be linked to 0V)
- 0V - PCB 0V connections
- SW - Switch connection (the main control button is connected across SW and 0V)
- EX4 - Do not use these connections
- EX5 - Do not use these connections
- FON - Force on function (see section 4.10.1 FORCE ON FUNCTION)
- VBAT - Positive side of battery (battery connected across VBAT and 0V)
- +Vcc - Positive side of external 24Vdc supply (supply connected across +Vcc and OUT)
- OUT - Negative side of external 24Vdc supply (supply connected across +Vcc and OUT)

Note that spring pins may be fitted at VBAT, TxTTL and RxTTL to make the connections to the BATTERY COMPARTMENT. Care must be taken to avoid damage or obstruction of these contacts. When replacing the BATTERY COMPARTMENT ensure that it is aligned correctly so that these connections are made properly.

4.10.1. FORCE ON FUNCTION

If the FON connection is linked to 0V the unit will automatically power on whenever there is 24Vdc present across +Vcc and OUT. This means that if there is an interruption to the external power supply then the unit will automatically turn on when the power supply recovers. The same power on sequence is followed as in section 4.1 TURNING ON except the control button does not need to be operated. The auto-power on feature will not operate if powered from internal batteries only.

If the unit is manually shutdown as per 4.7.5 SHUTDOWN then to re-activate the unit either temporarily remove external power or use the control button as per section 4.1 TURNING ON.

4.10.2. RELAY OUTPUT

The relay output is DPDT (Double Pole Double Throw) meaning that there are two separate sets of contacts (NC1 / COM1 / NO1 and NC2 / COM2 / NO2) which may be connected to two separate external circuits.

While in the LISTENING state (see section 4.3 LISTENING), the Normally Closed contacts of the relays will be connected to their respective Common contacts and the Normally Open contacts will be open.

While in the DETECTION state (see section 4.4 DETECTION MODE), the Normally Closed contacts of the relays will be open and the Normally Open contacts will be connected to their respective Common contacts.

4.10.3. CURRENT LOOP OUTPUT

Connect the positive side of the external 24Vdc supply to +Vcc and the negative side of the 24Vdc supply to OUT. Ensure that +21.6Vdc to +26.4Vdc is maintained at the unit connections.

While switched off the unit will consume less than 13.0mA.

While in the LISTENING state (see section 4.3 LISTENING), the unit will consume 15.0mA \pm 1.0mA.

While in the DETECTION state (see section 4.4 DETECTION MODE), the unit will consume 19.0mA \pm 1.0mA.

If the control button is pressed while in either state, then invalid (outside the ranges above) current levels may be seen.

4.11. RECOMMENDED MAGNET ARRANGEMENT

Refer to the table below for recommended quantities and type of magnets required for pipeline diameter and wall thickness. The magnets should be spaced equally around the pig body with all magnets oriented with the same poles facing outwards e.g., all north poles facing outwards (as shown) or all south poles facing outwards. It is critical that the magnets are not oriented with a mixture of north and south poles facing outwards as this may result in 'dead-spots' in the magnetic field around the pig. Magnets may be fixed to the pig body, embedded in the pig discs or embedded in foam pigs. The cost of quality magnets is insignificant compared to the potential cost of a lost pig which is more likely if unsuitable, cheaper magnets are used. Effective pig detection is dependent on several factors including:

PIPE WALL THICKNESS – The thinner the pipe wall, the stronger the magnetic signal.

PIPELINE MATERIAL – Different materials cause different attenuations to the magnetic signals. For example, 50mm of concrete will affect the signal considerably less than 50mm of mild steel.

DISTANCE BETWEEN MAGNET AND SENSOR – The closer the magnets are to the magnetic sensor, the stronger the magnetic signal.

NUMBER OF MAGNETS FITTED TO PIG – The more magnets which are placed around the pig, the more uniform and effective the overall magnetic field is.

STRENGTH OF MAGNETS – The stronger the magnets, the stronger the magnetic signal.

BACKGROUND MAGNETIC NOISE – The more magnetically quiet the surrounding area is, the more sensitive the signaller can be set without the risk of false triggers. Movement of magnetic objects close to the signaller should be avoided to prevent false triggers.

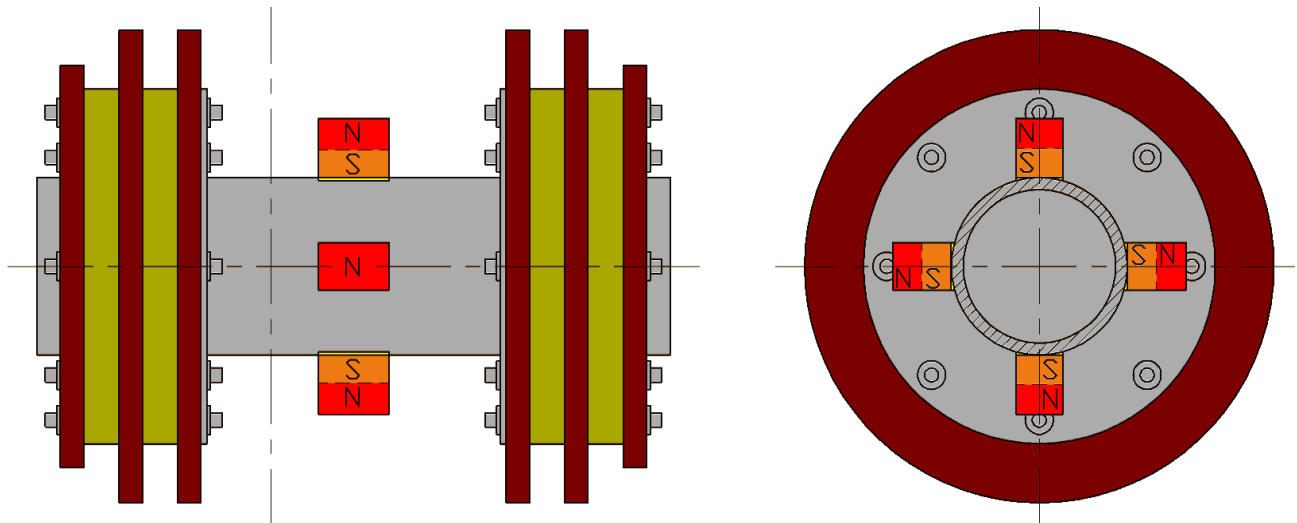

PIPELINE DIAMETER	PIPELINE WALL THICKNESS	MAGNET TYPE & DIMENSIONS	NUMBER OF MAGNETS EQUISPACED AROUND PIG
10"	10.2mm	NdFeB N35 ø20x20mm	8
10"	10.2mm	NdFeB N35 ø48x18mm	4
12"	11.3mm	NdFeB N35 ø20x20mm	8
12"	11.3mm	NdFeB N35 ø48x18mm	4
14"	12.1mm	NdFeB N35 ø20x20mm	8
14"	12.1mm	NdFeB N35 ø48x18mm	4
16"	13.2mm	NdFeB N35 ø20x20mm	8
16"	13.2mm	NdFeB N35 ø48x18mm	4

4.12. MEMORY BACKUP

The unit includes memory backup to retain date, time and user settings such as detection delay and threshold while the unit is turned off.

If the unit is turned off but main batteries or external power is left connected, then memory backup will retain these settings indefinitely.

If the unit is turned off and main batteries and external power are removed, then memory backup will retain these settings for a minimum of 50 days.

If memory backup expires then the warning message below will be displayed for 5 seconds when the units is next turned on. At this point all settings will reset to the default values shown in the table below and the user shall be prompted to set the time and date as per 4.7.10 SET DATE / TIME prior to the IK Trax logo being displayed.

Note that EVENTS will default to 99 which will allow all previously logged events to be read if required however it will not be possible to log any new events. To enable new events to be logged events must be deleted as per section 4.7.4 DELETE ALL EVENTS.

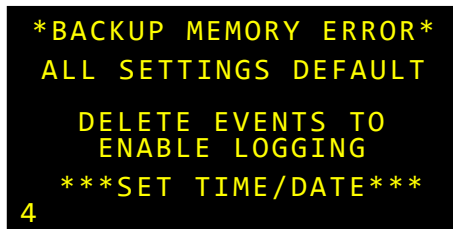

BACKUP MEMORY ERROR
ALL SETTINGS DEFAULT
DELETE EVENTS TO
ENABLE LOGGING
*****SET TIME/DATE*****
4

SETTING	DEFAULT VALUE
DATE	01/01/00
TIME	00:00:00
LOW POWER MODE	ENABLED
EVENTS	99
STABILISATION DELAY	00:01:00
DETECTION DELAY	00:01:00
THRESHOLD	35

5. ROUTINE MAINTENANCE AND STORAGE

All IK Trax products are designed to require minimum maintenance. The housing should be cleaned using fresh water and cleaning agents as necessary.

If the unit is to be placed in storage for a long period of time ensure the unit has been cleaned, turned OFF and main batteries removed. Refer to Section 8 ATEX / UKEX / IECEx APPENDIX.

6. DISPOSAL

IK Trax takes its responsibilities under the WEEE Regulations extremely seriously and has taken steps to be compliant in line with our corporate and social responsibilities. In the UK, IK Trax has joined a registered compliance scheme WeeeCare (registration number **WEE/MP3538PZ/SCH**).

Electrical and electronic equipment should never be disposed of with general waste but must be separately collected for the proper treatment and recovery.

The crossed-out bin symbol, placed on the product, reminds you of the need to dispose of it correctly at the end of its life.

When buying a new product, you will have the possibility to return, free of charge, another end of life product of equivalent type that has fulfilled the same functions as the supplied equipment. These items may be deposited at:

IK Trax
Online House
Woodburn Road
Blackburn Business Park
Blackburn
Aberdeen
AB21 0PS
UK

Alternatively, to arrange a collection of any waste electrical equipment, obligated to IK Trax please telephone WeeeCare on **0844 800 2004**.

7. WARRANTY

IK Trax products are guaranteed for one year from the date of purchase. Goods should be returned transportation prepaid to IK Trax.

There is no charge for parts or labour should any product require repair due to a manufacturing deficiency during the guarantee period.

In the event of a manufacturing deficiency the inward transportation costs will be repaid to the client.

8. ATEX / UKEX / IECEX APPENDIX

EQUIPMENT: 4001D Magnetic Pig Signaller

MANUFACTURER: **Online Electronics Ltd**
Online House
Blackburn Business Park
Woodburn Road
Blackburn
Aberdeen
AB21 0PS
UK
Tel: +44 (0) 1224 714 714
Web: www.iktrax.com

NOTIFIED BODY NUMBER: 2812 / 0891

ATEX CERTIFICATE: TRAC13ATEX0007X – Notified Body Number 2812

UKEX CERTIFICATE: EMA22UKEX0005X – Notified Body Number 0891

IECEX CERTIFICATE: IECEX TRC 12.0017X – Notified Body Number 0891

MARKINGS:  II 1/2 G Ex db ia [ia Ga] IIC T4...T6 Gb

APPLICABLE STANDARDS: EN 60079-0:2018
EN 60079-1:2014
EN 60079-11:2012
IEC 60079-0:2017
IEC 60079-1:2014
IEC 60079-11:2011
Equipment and Protective Systems Intended for Use in Potentially Explosive Atmospheres regulations 2016 (UKSI No. 1107, as amended).
Electromagnetic compatibility regulations 2016 (SI 2016 NO. 1091 as amended).

SPECIAL CONDITIONS FOR SAFE USE:

1. Do not open when an explosive gas atmosphere may be present.
2. Potential electrostatic charging hazard. The equipment should not be mounted in areas where it could be subjected to highly efficient charging mechanisms, such as fast-moving dust or particle filled air and shall only be cleaned with an anti-static or damp cloth.
3. Transducer, cable and electronics shall only be used as a complete assembly.
4. Internal and external threaded holes are provided for earthing and equipotential bonding. Protective earthing conductors employed shall be greater or equal to the size of the phase conductors, equipotential conductors shall have a minimum cross-sectional area of 4mm². The end user shall ensure conductors cannot be readily loosened or twisted. Light metals shall not be used unless special precautions are taken to guard against corrosion.
5. External power supply shall not exceed 30Vdc.
6. External power and signals shall only be supplied according to manufacturers' instructions using suitable cable and suitable Ex certified cable glands.

7. External power and signals shall only be connected using suitable crimp ferrules to prevent accidental disconnection.
8. Unused cable entries shall be sealed using suitable Ex certified blanking elements.
9. The temperature at the cable entry point may exceed +70°C. Cables suitable for use at this temperature must be used.
10. Use only ALKALINE, 1.5V, 18Ah, D cells, rated for at least 250mA continuous current (DURACELL INDUSTRIAL ID1300 recommended) OR LITHIUM THIONYL CHLORIDE, 3.6V, 17Ah, D cells, rated for at least 250mA continuous current (SAFT LS33600 recommended).
11. As part of the routine maintenance schedule, the condition of the window cement shall be periodically inspected for any degradation or discolouration of the cement that may compromise the explosion protection.
12. Temperature class is reliant on the operating ambient temperature, the internal power dissipation (Pd), and whether internal cells are fitted. Refer to the tables below for the allowable operating ambient temperatures.

Pd	External supply (NO CELLS FITTED)		
	T4	T5	T6
<1W	-40 to +85°C	-40 to +85°C	-40 to +75°C
<5W	-40 to +85°C	-40 to +85°C	-40 to +70°C
<10W	-40 to +80°C	-40 to +70°C	-40 to +55°C

Pd	DURACELL INDUSTRIAL ID1300 FITTED		
	T4	T5	T6
<1W	-20 to +54°C	-20 to +54°C	-20 to +54°C
<5W	-20 to +54°C	-20 to +54°C	-20 to +54°C
<10W	-20 to +54°C	-20 to +54°C	-20 to +54°C

Pd	SAFT LS33600 FITTED		
	T4	T5	T6
<1W	-40 to +85°C	-40 to +85°C	-40 to +75°C
<5W	-40 to +85°C	-40 to +85°C	-40 to +70°C
<10W	-40 to +80°C	-40 to +70°C	-40 to +55°C