



TRAX

Intelligent Pipeline
Technology

EMTx50 Operating Manual

Electromagnetic Transmitter



CONFIGURATION INFORMATION	
SERIAL NUMBER :	
PRODUCT CODE :	
FREQUENCY :	
PULSE LENGTH :	
REPETITION RATE :	
BATTERY LIFE AT +5°C :	

CONTENTS

Page

- 1. GENERAL DESCRIPTION 3
 - 1.1. ENDCAP OPTIONS..... 3
- 2. SPECIFICATIONS:..... 4
- 3. RULES FOR SAFE OPERATION 5
- 4. OPERATION 6
 - 4.1. TURNING ON..... 6
 - 4.2. TURNING OFF 6
 - 4.3. FUNCTION TEST 6
 - 4.4. CONFIGURATION 6
 - 4.4.1. EMTx CONFIG for Windows 7
 - 4.4.2 EMTX CONFIG FOR ANDROID 9
 - 4.5. INSTALLATION 11
 - 4.6. DEPLOYMENT 12
- 5. MAINTENANCE 13
 - 5.1. BATTERY REPLACEMENT 13
 - 5.2. BATTERY LIFETIME 15
 - 5.3. O-RING REPLACEMENT 15
 - 5.3.1. BLEEDSCREW 15
 - 5.3.2. BATTERY ENDCAP 16
- 6. STORAGE 17
- 7. DISPOSAL OF UNIT 17
- 8. WARRANTY 17
- 9. SAFETY INSTRUCTIONS..... 18

Revision	Updated By	Description of Update	Update Date
A00	ADY	CR01063: Initial release.	07/08/24

1. GENERAL DESCRIPTION

The EMTx50 EM Transmitter is an electromagnetic transmitter which can be used for pig tracking and locating functions. The transmitter operates effectively in buried pipelines, pipelines carrying gas or liquid and in pipeline bundles where acoustic transmitters are either less effective or ineffective.

The EMTx50 transmitter produces a very strong signal which can be detected through even the heaviest pipeline walls. Using the IK Trax EMTx Config application (Windows or Android) the transmitter frequency, power and pulse pattern can be configured to optimise performance and battery life. Received signal strength is dependent on several factors including pipeline diameter, pipeline material, pig design, pig speed, transmitter configuration, receiver equipment and background electromagnetic noise levels. Please contact IK Trax to discuss the most effective transmitter configuration.



1.1. ENDCAP OPTIONS

All EMTx50 transmitters comes fitted with PCB and Battery Endcaps as standard. The PCB Endcap incorporates a Bleedscrew and Bluetooth test port as a standard.

2. SPECIFICATIONS:

NOTE THAT THE SPECIFICATIONS BELOW ARE VALID FOR THE STANDARD CONFIGURATION ONLY. REFER TO PAGE 1 OF THIS MANUAL FOR THE CONFIGURATION INFORMATION SPECIFIC TO THE TRANSMITTER BEING USED.

Battery Type.....	Alkaline D Cell Pack
Lifetime at 100% power, continuous mode, +5°C (+41°F)	14 days
Lifetime at 100% power, continuous mode, +20°C (+68°F).....	18 days
Lifetime at 100% power, 0.4s ON / 2.6s OFF pulse rate, +5°C (+41°F).....	110 days
Lifetime at 100% power, 0.4s ON / 2.6s OFF pulse rate, +20°C (+68°F).....	138 days
Lifetime in other configurations	See 5.2 BATTERY LIFETIME
Frequency	adjustable 10Hz to 30Hz in 0.1Hz increments
Power	adjustable 10% to 100% in 10% increments
Pulse length.....	adjustable 0.3 second to 1.0 second in 0.1 second increments
Pulse rate.....	adjustable 1 second to 10 seconds in 1 second increments
Temperature range.....	-20°C to + 50°C (-4°F to + 122°F)
Bump rating.....	20G
Housing and Battery Endcap material.....	Ertacetal C
PCB Endcap material.....	316L Stainless Steel
O-ring material	NBR70 & NBR90
Transmitter weight in (including batteries).....	24kg (52.9lbs)
Length	558mm
External pressure rating in.....	153bar (2200psi)

3. RULES FOR SAFE OPERATION

⚠ WARNING: The Special Conditions for Safe Use as detailed in section 9 must be followed at all times.

⚠ WARNING: Any operation involving pressure is potentially hazardous. No person should use this equipment unless they are fully aware of the potential hazards of working with pressurised vessels. The purchaser of this equipment is responsible for the training and competence of operators and the manner in which it is used. This manual should be read through and understood before installation and commissioning so that the operator is familiar with the equipment. Contact IK Trax immediately should any difficulty arise in the use of this equipment.

⚠ WARNING: DO NOT open when an explosive atmosphere may be present. Always use caution when opening equipment which has been in a pressurised environment. It is possible for pressure to leak into the equipment and remain there even after external pressure has been removed. ALWAYS point the end to be opened towards a safe area and away from yourself or others. Contact IK Trax immediately if there is a suspicion that the equipment has become pressurised.

⚠ WARNING: USE ONLY IK Trax new Alkaline D Cell battery Pack. ALWAYS observe correct battery polarity. A new battery pack should be installed before each deployment.

⚠ WARNING: Do not expose to aggressive solvents or chemicals which could be harmful to the HOUSING, O-RINGS, CONNECTORS or any other parts of the equipment.

⚠ CAUTION: This equipment should only be opened in a clean laboratory environment.

⚠ CAUTION: To prevent the formation of condensation within the transmitter, allow the transmitter temperature to stabilise within the laboratory environment for a minimum of 6 hours prior to opening.

⚠ CAUTION: It is possible for liquids to become trapped in threads and/or gaps around openings. ALWAYS point the end to be opened downwards to allow any trapped liquid to drain out of and not into the equipment.

4. OPERATION

The following instructions are for a unit fitted with the standard Battery Endcap and PCB Endcap.

1. Familiarise yourself with all the rules for the safe operation of this equipment as described in Section 3 RULES FOR SAFE OPERATION.

4.1. TURNING ON

1. To turn the transmitter on, use an M6 Allen key to make up the Bleedscrew flush to the PCB Endcap, do not use excessive torque. Note that very little torque is required. Damage may occur if over tightened. The transmitter takes approximately 15 seconds to turn on.
2. Use an EM receiver such as the IK Trax EMRxEEx to confirm that the transmitter has turned on.

4.2. TURNING OFF

1. To turn the transmitter off, use an M6 Allen key to remove the Bleedscrew to the PCB Endcap. the transmitter should turn off immediately.
2. Use an EM receiver such as the IK Trax EMRxEEx to confirm that the transmitter has turned off.

4.3. FUNCTION TEST

An EM receiver, such as an IT Trax EMRxEEx Receiver is required to receive the signal from the transmitter. Refer to the relevant EM receiver manual for instruction on setup and operation of the EM receiver.

1. Place the EM receiver antenna approximately 4m away and parallel to the transmitter.
2. Activate the transmitter as detailed in Section 4.1 TURNING ON.
3. Confirm that a clear signal is received, and the pulse rate is as expected.
4. Switch the transmitter between OFF and ON a few times to ensure that the signal received reacts as expected.
5. An inherent null spot is detectable when the antenna is at 90 degrees to and pointing towards the centre of the transmitter allowing accurate positioning of a pig. Refer to the relevant EM receiver manual for further information.
6. Turn OFF the transmitter as detailed in Section 4.2 TURNING OFF.
7. If all results were as expected, then the system is functional.

4.4. CONFIGURATION

An EM Transmitter has configurable parameters that can be changed via a Bluetooth connection using either the EMTx CONFIG for Windows app or the EMTx CONFIG for Android app. Ensure that the laptop/desktop computer or Android mobile phone/tablet has Bluetooth turned on and that all devices are discoverable. If the laptop/desktop does not have built in Bluetooth, a USB Bluetooth dongle can be used; see the EMTx CONIG manual for more details. The following section assume built in Bluetooth in Windows 10 (or 11).

4.4.1. EMTX CONFIG FOR WINDOWS

1. Follow the instructions contained in the EMTx CONFIG for Windows User Manual.
2. Install the latest version of EMTx CONFIG for Windows via the IKTrax website.
3. Run the application. The Configure Tab will be highlighted by default as will Windows 10 Bluetooth connection method. Bluetooth will scan for EMTx devices as shown below.

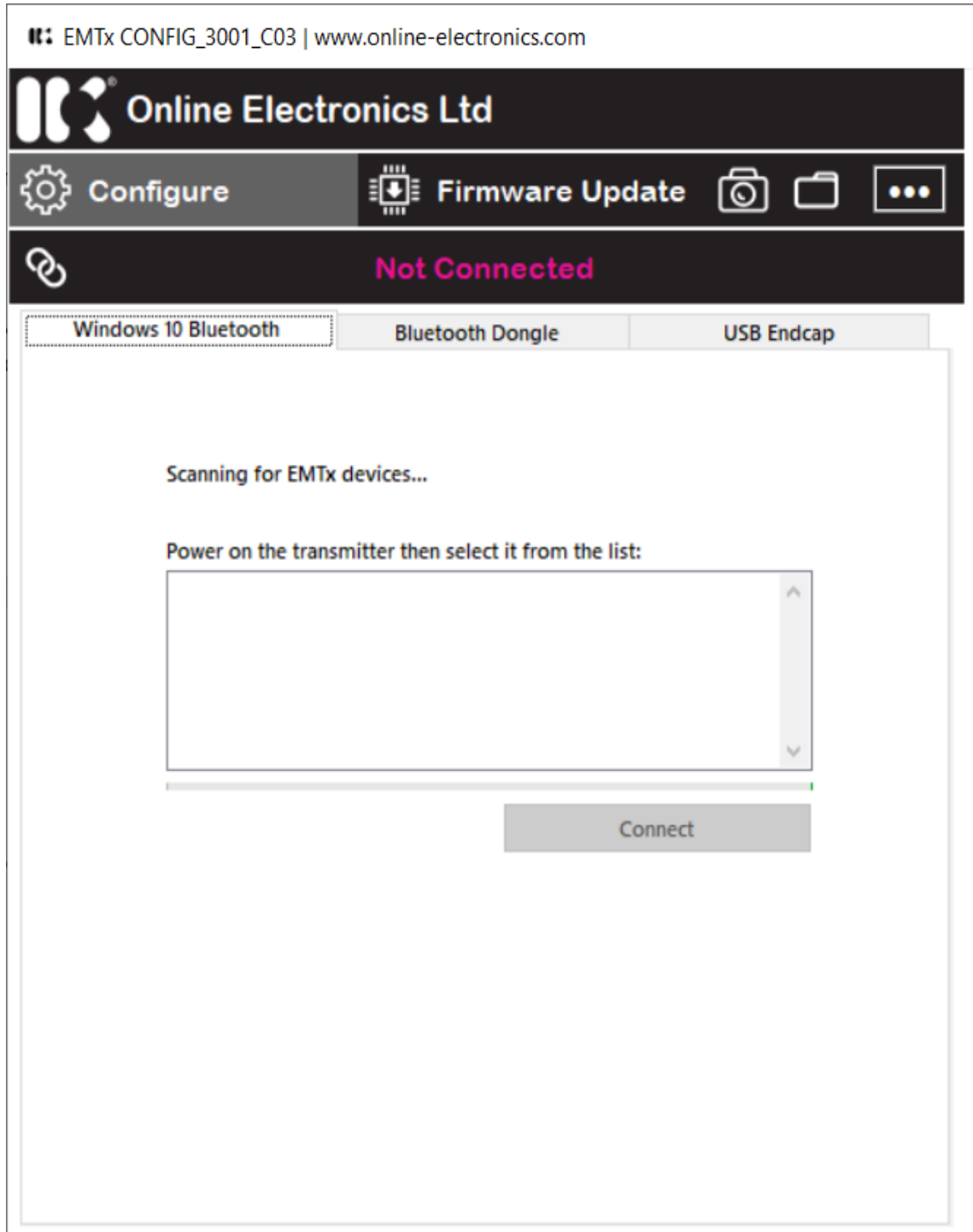

4. The transmitter, when turned on, will be discoverable on Bluetooth for 15 seconds. During this time 'Connect' to the EMTx50 as shown below

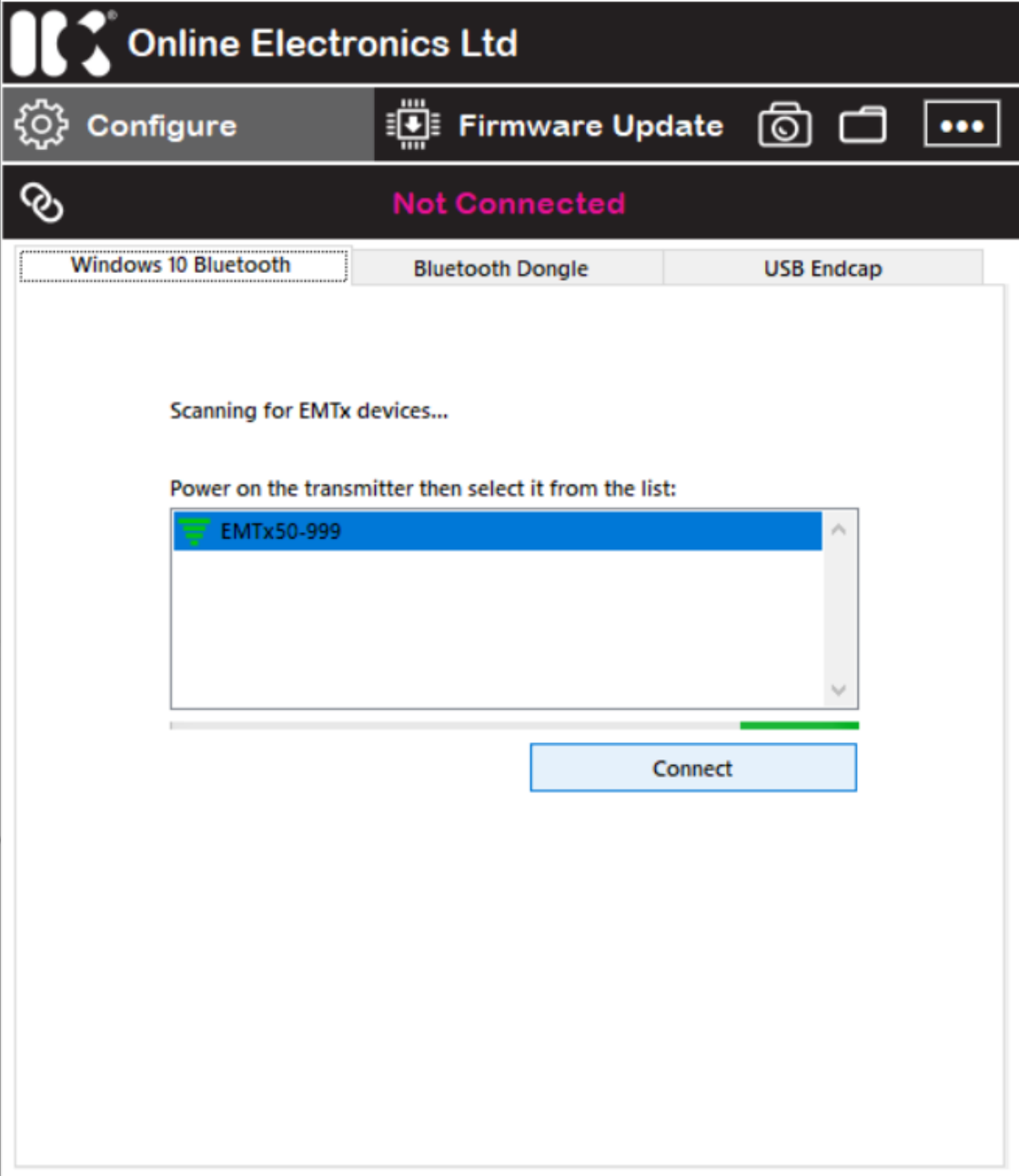

5. Once connected, the following parameters can be configured:

- Power Setting
- Pulse Rate
- Pulse Length
- Start Delay
- Frequency

EMTx CONFIG_3001_C03 | www.online-electronics.com

Online Electronics Ltd

Configure Firmware Update

EMTx Connected

Configuration Synced

Details

Model No: EMTx50U-0D285C V01	Serial No: 999	Cfg Val:
Firmware: EMTx50_3001_B01	Bootloader: EMTx50_3002_B00	21F02001

Power Setting

Battery Life at +5°C: 14.4 days

MIN  MAX 100%

Pulse Settings

Rate: Cont s Start Delay: 0 days

Length: N/A s Frequency: 30.0 Hz

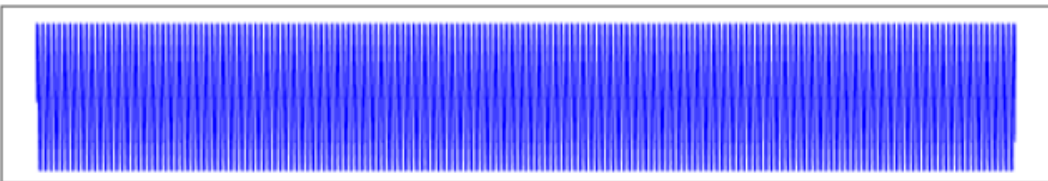

Configure Dual Rate Zoom + 6s -

Sync & Disconnect Disconnect

6. Once the changes required have been made, select 'Sync and Disconnect' for the changes to take effect. The transmitter will start to run with the new parameters. To discard all changes select 'Disconnect'. The transmitter will start running with the previous configured settings.

4.4.2 EMTX CONFIG FOR ANDROID

1. Follow the instructions in the EMTx CONFIG for ANDROID User Manual.
2. Download and install the latest version of EMTx CONFIG for ANDROID from the Google Play Store.
3. Run the application.

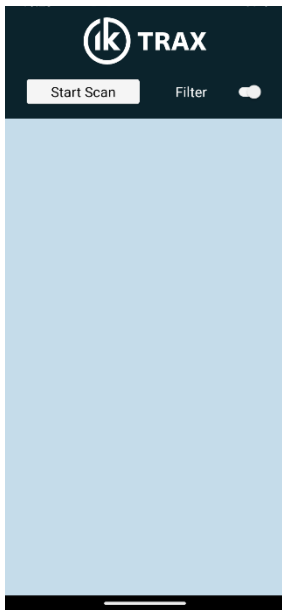

4. Click on 'Start Scan'.
5. The transmitter, when turned on, will be discoverable on Bluetooth for 15 seconds. During this time 'Connect' to the EMTx50.

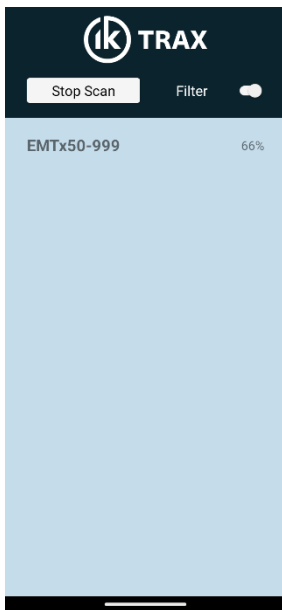

6. Once connected, the following parameters can be configured:

Transmit Frequency
Transmit Rate
Power
Activation Delay

(depending on screen size/orientation, the user may have to scroll to see all configurable parameters).

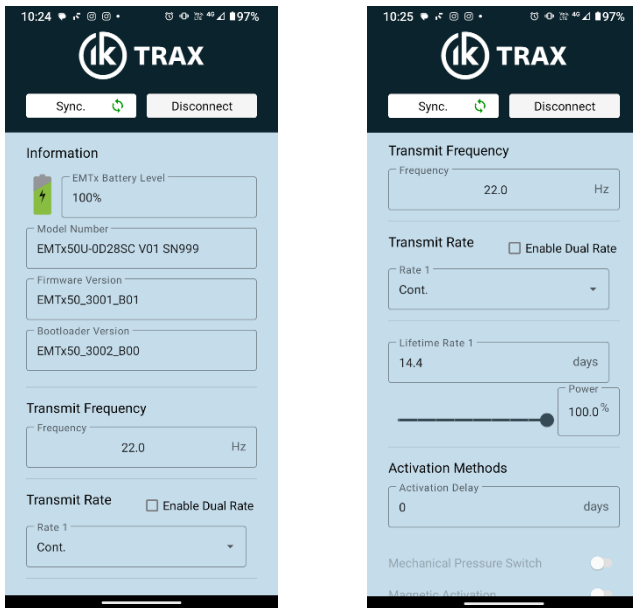

7. Once the changes required have been made, select 'Sync' and then 'Disconnect' for the changes to take effect. To discard any changes simply select 'Disconnect'.

4.5. INSTALLATION

⚠ WARNING: The Special Conditions for Safe Use as detailed in SECTION 9 must be always followed.

⚠ WARNING: The transmitter must be mounted in such a way that no movement or vibration is possible whatsoever (e.g. clamped). If the transmitter is allowed to rattle and/or vibrate within the pig then the resultant hammering effect can exceed the bump rating of the transmitter leading to damage and/or failure. This is particularly important in gas pipelines.

⚠ CAUTION: All EM transmitters will induce electrical currents in any conductive materials closely surrounding them which can result in a severe reduction in signal strength and/or battery lifetime. This effect can be minimised by reducing the amount of conducting material surrounding the transmitter and leaving as much of the transmitter exposed as possible. Any slits or apertures which can be made in the surrounding material will help. Use materials with as high resistance as possible. Non-conducting materials such as plastics will not suffer from this effect. EM transmitters must not be surrounded by low resistance metals such as aluminium (including tubes or mounting clamps) under any circumstances.

⚠ CAUTION: Any magnetic material surrounding the transmitter will tend to block the EM signal from the transmitter and reduce the received signal strength outside the pipeline. This effect can be minimised by reducing the amount of magnetic material surrounding the transmitter and leaving as much of the transmitter exposed as possible. Any slits or apertures which can be made in the surrounding material will help. Use materials with as low magnetic permeability as possible. Non-magnetic materials such as plastics will not suffer from this effect. The table below shows the typical characteristics of several potential pig and mounting materials with the best choice at the top, and the worst choice at the bottom. 316 stainless steel provides a good balance of properties and cost. An aluminium alloy would be a very poor choice because of the very low resistivity and should not be used under any circumstances.

MATERIAL	RESISTIVITY ($\mu\Omega.m$)	MAGNETIC PERMEABILITY
PLASTIC	∞	1.000
316 STAINLESS STEEL	0.75	1.008
2205 DUPLEX SS	0.80	>25.0
1005 STEEL	0.20	>100
ALUMINIUM ALLOYS	0.04	1.000

For optimum performance the transmitter should be clamped inside a plastic pig body. A alternative mounting arrangement is shown below. It uses several lengths of threaded studding to clamp the transmitter between two plates. The advantage of this arrangement is that it has limited amounts of metal around the transmitter and will therefore have limited effect on the transmitter performance. Please contact IKTRAX for further information and guidelines regarding EM transmitter mounting and installation.

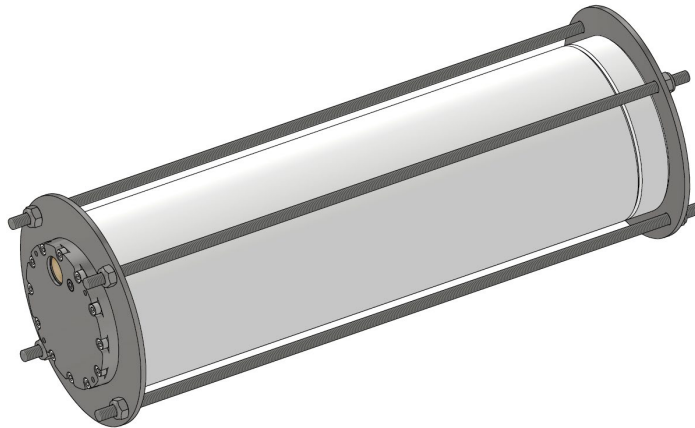

⚠ CAUTION: In extreme circumstances strong magnets in close proximity to EM transmitters may dramatically impact signal and lifetime. Where possible maintain a separation of at least 200mm between the EM transmitter and any magnets.

4.6. DEPLOYMENT

Before each deployment ensure that the following checks have been completed.

1. Ensure that the transmitter has been installed as detailed in Section 4.3 INSTALLATION.
2. Visually inspect all system components to ensure that they are secure and undamaged.
3. Refer to Page 1 of this manual for the expected battery lifetime and ensure that it is adequate for the planned operations.
4. Activate the transmitter as detailed in Section 4.1 TURNING ON.
5. Complete a Section 4.3 FUNCTION TEST.

5. MAINTENANCE

Familiarise yourself with all of the rules for the safe operation of this equipment as described in Section 3 RULES FOR SAFE OPERATION.

The EMTx50 EM transmitters are designed to require minimum maintenance. The transmitter should be cleaned using fresh water and cleaning agents as necessary (e.g. WD40). Do not use chemicals which could be damaging to the housing or O-rings.

Check flame paths / threads on the housing body and endcaps for signs of corrosion or damage. If badly pitted or damaged, consult IK Trax for advice on replacing the relevant part.

All parts which are replaced must be in accordance with the manufacturers' specifications. Failure to use such components may invalidate the certification/approval and may make the equipment dangerous.

IK Trax can supply redress kits containing a complete set of replacement battery packs, O-rings, O-ring grease and thread lubricant, contact IK Trax for more information.

5.1. BATTERY REPLACEMENT

1. Familiarise yourself with all warnings given at the start of Section 3 RULES FOR SAFE OPERATION. Refer to below diagram outlining all parts involved for battery replacement.

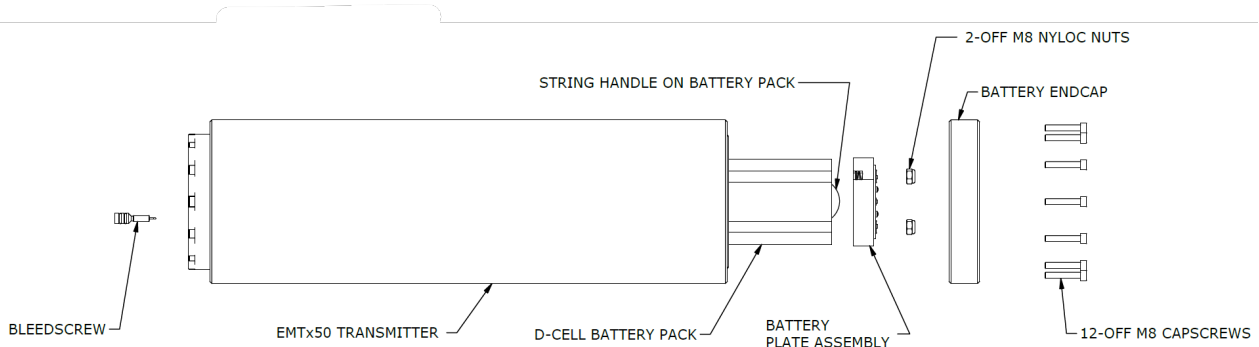

2. Remove the BLEEDSCREW from PCB ENDCAP using an M6 Allen key to turn off transmitter. Be cautious of potential trapped pressure in the enclosure and adhere to instructions given in Section 3 on how to safely remove the BLEEDSCREW.
3. Remove BATTERY ENDCAP from HOUSING by removing 12-off M8x70 Capscrews using an M8 Allen key.

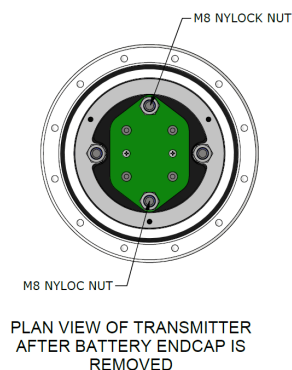

4. Examine the O-ring seals for any signs of contamination or damage, replace and/or re-grease if necessary. Refer to Section 5.3 O-RING REPLACEMENT for guidance.
5. Remove 2-off TYPE A NYLOC NUTS from the BATTERY PLATE ASSEMBLY as shown above and then remove the BATTERY PLATE ASSEMBLY from the transmitter. **Ensure that the M8 RODS do not rotate/become free during this process. Contact IK TRAX immediately if this occurs.**
6. Remove D-CELL BATTERY PACK from the transmitter by use of the string handle on the battery pack.
7. Observing correct battery pack orientation as shown above (string handle at free end of transmitter), insert new D-CELL BATTERY PACK into the transmitter until its butted against D-cell springs at the bottom of the transmitter. Note that the 4x slots on the battery pack align with 4x M8 rods in the transmitter.

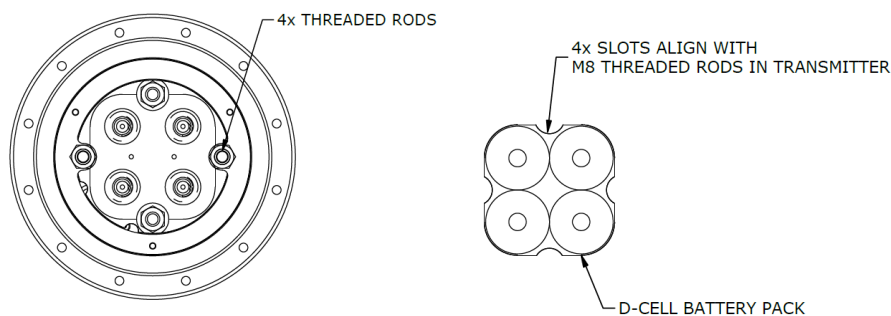

8. Once D CELL BATTERY PACK is installed, ensure when looking into the open end of the transmitter with the string handle is available for removal for future battery replacements.
9. Slide BATTERY PLATE ASSEMBLY into the transmitter with the holes engaging the inner M8 Rods (a black section of heat shrink can be seen on these rods only) and secure with 2-off M8 NYLOC NUTS. Ensure correct orientation of BATTERY PLATE ASSEMBLY, the D-cell springs on the BATTERY PLATE ASSEMBLY will contact the BATTERY PACK if installed correctly. Tighten M8 NYLOC NUTS until they contact BATTERY PLATE ASSEMBLY.
10. Examine the O-ring seal on the transmitter for any signs of contamination or damage, replace and/or re-grease if necessary. Refer to Section 5.3 O-RING REPLACEMENT for guidance.
11. Secure the BATTERY ENDCAP to the transmitter with 12-off M8x70 Capscrews and tighten to 8Nm. Ensure head of Capscrews locate in counterbored holes in BATTERY ENDCAP.
12. Examine the O-ring seal on the BLEEDSCREW for any signs of contamination or damage, replace and/or re-grease if necessary. Refer to Section 5.3 O-RING REPLACEMENT for guidance.
13. Install BLEEDSCREW into PCB ENDCAP partially to secure the Bleedscrew. Make up the BLEEDSCREW fully if the transmitter is to be switched on. Refer to section 4.1 for switching the unit on.

5.2. BATTERY LIFETIME

The operating temperature at which the transmitter is used alters the operating lifetime with colder temperatures typically shortening achievable lifetime.

Transmitter frequency effects lifetime because pulse lengths are restricted to a whole number of cycles of the transmitter frequency. The lifetimes stated in this manual are all at 22.0Hz unless stated otherwise and will not vary by more than 10% at other frequencies. The EMTx Config Windows and Android applications include the effects of frequency in their lifetime predictions.

In extreme circumstances the transmitter operating lifetime may be reduced by how the transmitter is installed on a pig. Refer to section 4.3 INSTALLATION within this manual for tips on how to achieve optimum performance from the transmitter with regards to the mounting arrangement.

The tables below show predicted lifetimes for a range of configurations. The mVpp values show the predicted signal received in open air at 1m with IK Trax reference antenna.

Please contact IK Trax to discuss any project specific requirements.

EMTx50 predicted lifetimes (days), 0.4s pulse length, +5°C						
Power Setting	Cont.	1 sec	2 sec	3 sec	4 sec	5 sec
100% (2400mVpp)	14.4	36.8	73.6	110.4	147.2	184
50% (1600mVpp)	28.9	73.6	147.2	220.7	294.3	367.9
20% (960mVpp)	72.2	184	367.9	551.9	735.8	919.8

EMTx50 predicted lifetimes (days), 0.4s pulse length, +20°C						
Power Setting	Cont.	1 sec	2 sec	3 sec	4 sec	5 sec
100% (2400mVpp)	18	46	92	138	184	230
50% (1600mVpp)	36.1	92	184	275.9	367.9	459.9
20% (960mVpp)	90.3	230	459.9	689.9	919.8	1149.8

5.3. O-RING REPLACEMENT

5.3.1. BLEEDSCREW

1. Using an M6 Allen key, remove the BLEEDSCREW from the PCB ENDCAP.
2. Referring to the figure below, remove all O-rings and clean all sealing surfaces on all parts.



3. Examine all surfaces for signs of corrosion, scoring, and other damage. If there is excessive damage the mechanical parts may need to be replaced.
4. Lightly grease all sealing surfaces using a suitable grease (e.g. DOW CORNING MOLYKOTE 111 COMPOUND).
5. Lightly grease each O-ring with a suitable grease (e.g. DOW CORNING MOLYKOTE 111 COMPOUND) before fitting.
6. Apply a small amount of an oil-based thread lubricant such as "Blue Goop" to the BLEEDSCREW threads. Refer to section 5.1 Step 13 for instruction on installing the BLEEDSCREW.

5.3.2. BATTERY ENDCAP

1. Remove BATTERY ENDCAP from HOUSING by removing 12-off M8x70 Capscrews using an M8 Allen key.
2. Referring to the figure below, remove O-ring and clean all sealing surfaces on all parts.

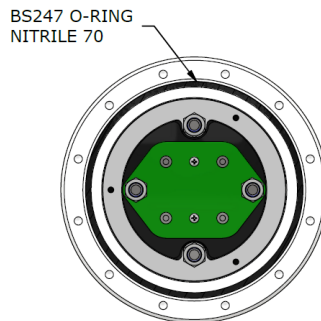

3. Examine all surfaces for signs of corrosion, scoring, and other damage. If there is excessive damage the mechanical parts may need to be replaced.
4. Lightly grease all sealing surfaces using a suitable grease (e.g. DOW CORNING MOLYKOTE 111 COMPOUND).
5. Lightly grease each O-ring with a suitable grease (e.g. DOW CORNING MOLYKOTE 111 COMPOUND) before fitting in the groove in the BATTERY ENDCAP.
6. Apply a small amount of an oil-based thread lubricant such as "Blue Goop" to the 12-off M8x70 Capscrews before fitting. Refer to section 5.1 Step 13 for instruction on installing the BLEEDSCREW.

6. STORAGE

Familiarise yourself with all of the rules for the safe operation of this equipment as described in Section 3 RULES FOR SAFE OPERATION.

If the transmitter is to be placed in storage for a long period of time remove the batteries from the transmitter and store separately.

As a minimum the BLEEDSCREW must be loosened 5 full turns to switch the transmitter off.

7. DISPOSAL OF UNIT

IK Trax takes its responsibilities under the WEEE Regulations extremely seriously and has taken steps to be compliant in line with our corporate and social responsibilities. In the UK, IK Trax has joined a registered compliance scheme WeeeCare (registration number **WEE/MP3538PZ/SCH**).

Electrical and electronic equipment should never be disposed of with general waste but must be separately collected for the proper treatment and recovery.

The crossed-out bin symbol, placed on the product, reminds you of the need to dispose of it correctly at the end of its life.

When buying a new product, you will have the possibility to return, free of charge, another end-of-life product of equivalent type that has fulfilled the same functions as the supplied equipment. These items may be deposited at:

Online Electronics Ltd
Doing business as IK Trax
Blackburn Business Park
Woodburn Road
Blackburn
Aberdeen
AB21 0PS
UK

Alternatively, to arrange a collection of any waste electrical equipment, obligated to IK Trax please telephone WeeeCare on **0844 800 2004**.

8. WARRANTY

IK Trax products are guaranteed for one year from the date of purchase. Goods should be returned transportation prepaid to IK Trax.

There is no charge for parts or labour should any product require repair due to a manufacturing deficiency during the guarantee period.

In the event of a manufacturing deficiency the inward transportation costs will be repaid to the client.

9. SAFETY INSTRUCTIONS

SPECIAL CONDITIONS FOR SAFE USE:

1. Only use a new IK TRAX D-CELL BATTERY PACK.
2. The battery pack must be installed into the enclosure in accordance with section 5.1.
3. Repair of flame paths is not permitted by the end user.
4. Do not open when an explosive atmosphere may be present.
5. Units must be installed such that ignition sources due to impact and friction sparks are excluded.
6. Where used, the bleed screw must be tightened to a torque between 4Nm and 8Nm. Do not exceed 8Nm.