



TRAX

**Intelligent Pipeline
Technology**

EMRx Onshore & EMRx Ex Operating Manual

Electromagnetic Receiver

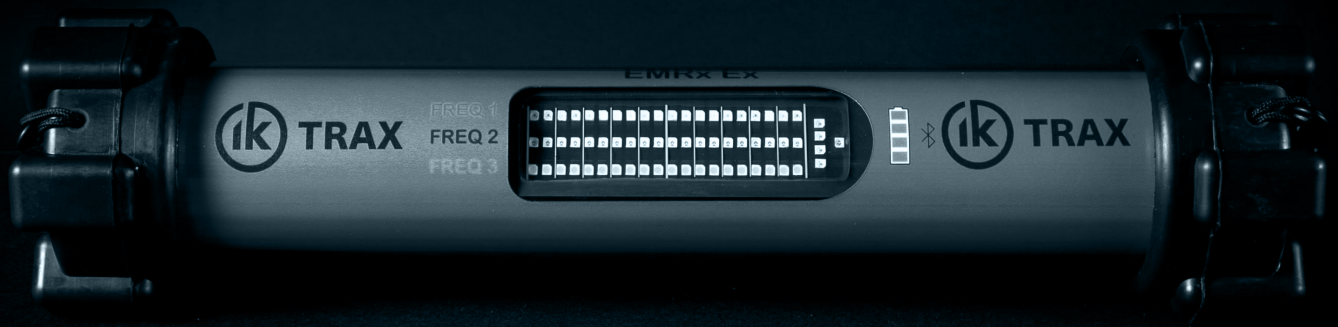

CONTENTS

Page

1.	GENERAL DESCRIPTION	4
2.	SPECIFICATIONS.....	6
2.1.	EMRx ONSHORE	6
2.2.	EMRx Ex.....	6
3.	OPERATION	7
3.1.	EMRx ONSHORE	7
3.2.	EMRx Ex (in addition to all above).....	7
3.3.	DEPLOYMENT CONSIDERATIONS AND TRACKING TIPS	8
3.4.	TURNING ON	9
3.5.	MEASUREMENT DISPLAY	10
3.6.	GAIN ADJUSTMENT.....	10
3.7.	TURNING OFF	11
3.8.	FREQUENCY AND MAGNETIC THRESHOLD	11
3.8.1.	MANUAL ADJUSTMENT	11
3.8.2.	SOFTWARE ADJUSTMENT.....	12
3.9.	FUNCTION TEST	12
3.9.1.	EM FUNCTION	12
3.9.2.	MAGNETIC FUNCTION	13
3.10.	APPROXIMATE TRANSMITTER LOCATION	13
3.11.	ACCURATE TRANSMITTER POSITION	15
3.12.	BATTERY REPLACEMENT	16
4.	EMRx ANDROID APPLICATION.....	18
4.1.	ANDROID USAGE CONSIDERATIONS	18
4.2.	ANDROID INSTALLATION.....	19
4.3.	ANDROID ESTABLISHING BLUETOOTH CONNECTION.....	20
4.4.	ANDROID MAIN MENU.....	21
4.5.	ANDROID SIGNAL STRENGTH CHART	22
4.6.	ANDROID INTENSITY CHART.....	24
4.7.	ANDROID SPECTRUM CHART.....	25
4.8.	ANDROID SETTINGS	26
4.9.	ANDROID MARKERS.....	28
4.9.1.	PLACING A MARKER.....	28
4.9.2.	NAVIGATING BETWEEN MARKERS.....	28
4.9.3.	MOVING A MARKER.....	28
4.9.4.	ADDING NOTES TO A MARKER.....	29
4.9.5.	DELETING A MARKER	29
4.9.6.	EXPORTING DATA LOG FILE	30
4.10.	ANDROID EXCESSIVELY LARGE INPUT WARNING.....	31
4.11.	ANDROID SCREENSHOT	31
5.	EMRx WINDOWS APPLICATION	32
5.1.	WINDOWS USAGE CONSIDERATIONS.....	32
5.2.	WINDOWS INSTALLATION	33
5.3.	WINDOWS BLUETOOTH PAIRING	33
5.4.	WINDOWS ESTABLISHING BLUETOOTH CONNECTION	34
5.5.	WINDOWS RIBBON CONTROLS.....	35
5.6.	WINDOWS INTENSITY CHART	36
5.7.	WINDOWS SIGNAL STRENGTH CHART.....	37
5.8.	WINDOWS SPECTRUM CHART	39
5.9.	WINDOWS RAW CHART	39
5.10.	WINDOWS SETTINGS.....	40
5.10.1.	CONNECTION CONFIGURE GROUP	40
5.10.2.	HARDWARE CONFIGURE GROUP	41
5.10.3.	SOFTWARE CONFIGURE GROUP.....	41
5.10.4.	EMRx Magnetic.....	42
5.10.5.	FIRMWARE CONFIGURE GROUP.....	43
5.11.	WINDOWS EXCESSIVELY LARGE INPUT WARNING	44
5.12.	WINDOWS SCREENSHOT.....	45

5.13.	DATA LOGGING.....	45
6.	ROUTINE MAINTENANCE AND STORAGE	46
7.	DISPOSAL OF UNIT.....	46
8.	WARRANTY.....	46
9.	CERTIFICATION APPENDIX	47

1. GENERAL DESCRIPTION

The IK Trax EMRx Onshore receiver is a robust, state of the art, multifrequency, electromagnetic (EM) receiver used for tracking pigs fitted with any EM pig transmitters. It can be used to confirm a pig has left or arrived at a particular location, for general monitoring of pig movements and for location of stuck or stalled pigs. The enhanced sensitivity permits the detection of transmitters even within very heavy walled receivers/launchers, pipeline bundles or Pipe-in-Pipe. The EMRx Ex is an intrinsically safe hazardous area Zone 0 / Class I Div I certified version with the same capabilities.

The EMRx provides three colour coded (red, blue and white) 20x LED bar graphs which can be individually configured in the field via Bluetooth using the IK Trax EMRx Android or Windows application (see sections 4 EMRx ANDROID APPLICATION and 5 EMRx WINDOWS APPLICATION) to display received signal at any fixed frequency between 10Hz and 30Hz. The LED frequencies can be pre-configured at IK Trax if required (default frequencies are red 17Hz, blue 22Hz, white 27Hz).

The EMRx can also detect and display, on the top row of LEDs, the MAGNETIC flux generated by magnets mounted on a pig passing through a pipe on which it is located. A flux threshold can be configured which, if exceeded, causes the top row of LEDs to flash indicating a pig passage.

A single control button allows gain adjustment as well as turning the unit on and off. Gain setting is indicated by a vertical line across the three 20x LED bar graphs.

The EMRx Onshore is powered from 6x standard AA Alkaline cells

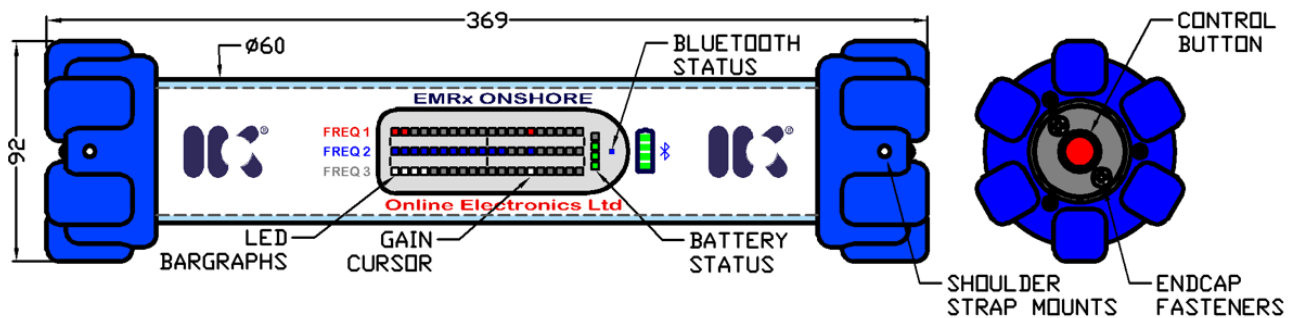

⚠ See 9 CERTIFICATION APPENDIX for allowable battery types for EMRx Ex

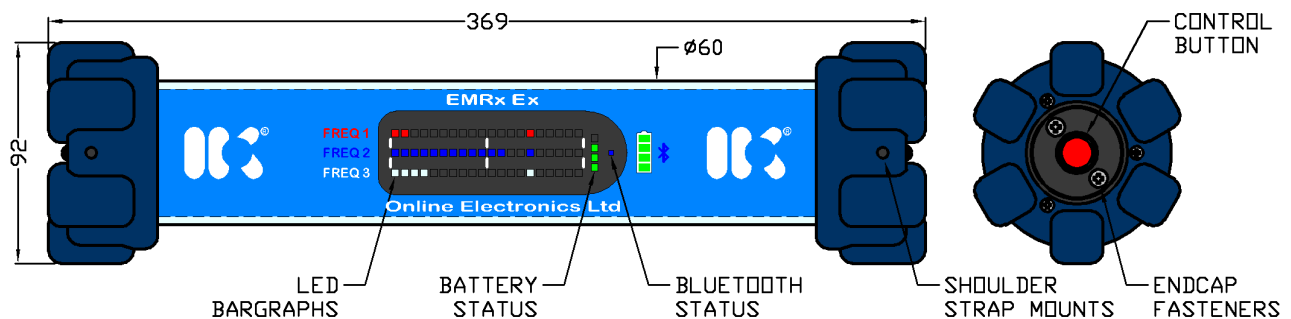

The image above shows:

- The EM frequency set on all 3 rows of the LEDs
- A gain setting of 15x LEDs out of 20 (75%).
- Top LED bar graph (red) shows a signal level of 2x LEDs out of 20 (10%).

- Middle LED bar graph (blue) shows a signal level of 12x LEDs out of 20 (60%).
- Bottom LED bar graph (white) shows a signal level of 4x LEDs out of 20 (20%).
- A battery level of 3x LEDs out of 4 (75%).

The EMRx may be interfaced to the EMRx Android or Windows application via Bluetooth which allows advanced receiver functionality including the ability to simultaneously receive any number of different frequencies between 10Hz and 30Hz, an audio output, and configuration of all receiver parameters such as the colour coded LED frequencies. The EMRx unit uses modern Digital Signal Processing (DSP) to provide enhanced functionality, signal-to-noise ratio and frequency selectivity.

This combination of features and functionality has the potential to greatly reduce operational downtime by facilitating confirmation of pig launch, pig passage and pig receipt as well as speedy location of a stuck pig.

Detection through pipeline walls in excess of 40mm thick is possible dependent on several factors including the type of transmitter used, distance between receiver and transmitter, pig design, pig speed, pipeline diameter, pipeline material and background EM noise levels. Please contact IK Trax to discuss the most effective configuration.

2. SPECIFICATIONS

2.1. EMRx ONSHORE

Typical lifetime used continuously with Bluetooth.....	30 hours
Typical lifetime used continuously without Bluetooth	100 hours
Battery type	6 x 1.5V, Alkaline, AA cells
Frequency range	10Hz to 30Hz
Magnetic flux range	200 milli-Gauss
Operating temperature range.....	-20°C to +50°C (-4°F to 122°F)
Weight	1.8 kg (4.0 lbs)
Housing material.....	Polycarbonate
Endcap material	Acetal
Endcap bumper material	EPDM rubber

2.2. EMRx Ex

Typical lifetime used continuously with Bluetooth.....	30 hours
Typical lifetime used continuously without Bluetooth	100 hours
Battery type	6x AA, 1.5V (Duracell MN1500 or Energizer L91)
Frequency range	10Hz to 30Hz
Operating temperature range.....	See 9 CERTIFICATION APPENDIX
Weight	1.9 kg (4.2 lbs)
Housing material.....	Polycarbonate
Endcap material	Acetal
Endcap bumper material	EPDM rubber
Ingress Protection	IP54
Certification markings.....	 II 1 G Ex ia IIC T4 Ga
UKEx Certificate Number	EMA 22 UKEx 0049 X
EU Type Examination Certificate Number	ERO 22 ATEX 0008 X
IECEX Certificate Number	IECEX EMT 22.0003 X

3. OPERATION

3.1. EMRx ONSHORE

- ⚠ WARNING:** The instructions detailed within the product certificate and the Special Conditions for Safe Use as detailed in section 9 CERTIFICATION APPENDIX of this manual must be followed at all times.
- ⚠ WARNING:** Replace all batteries at the same time. NEVER install used batteries. NEVER install a mix of new and used batteries. USE ONLY new batteries from the same package or manufacturing batch. DO NOT mix different brands or types of batteries. ALWAYS observe correct battery polarity. New batteries should be installed before each deployment.
- ⚠ CAUTION:** Opening of the equipment should only take place in a clean and dry environment.
- ⚠ CAUTION:** To prevent the formation of condensation within the equipment avoid opening the equipment when the equipment is colder than the surrounding environment. If possible, allow the equipment temperature to stabilise within the surrounding environment for a minimum of 6 hours prior to opening.
- ⚠ CAUTION:** It is possible for liquids to become trapped in threads and/or gaps around openings. ALWAYS point the end to be opened downwards to allow any trapped liquid to drain out of and not into the equipment.
- ⚠ CAUTION:** If the equipment is to be placed in storage, always ensure that it is turned OFF and the batteries are removed and stored separately.

3.2. EMRx Ex (in addition to all above)

- ⚠ WARNING:** The instructions detailed within the product certificate and the Special Conditions for Safe Use as detailed in section 9 EMRx Ex CERTIFICATION APPENDIX of this manual must be followed at all times.

3.3. DEPLOYMENT CONSIDERATIONS AND TRACKING TIPS

1. Confirm that the 3x LED bar graph frequencies are configured to the required frequencies as per 3.4 TURNING ON and that a note has been taken of these frequencies. These frequencies can be changed as described in sections 4 EMRx ANDROID APPLICATION or 5 EMRx WINDOWS APPLICATION.
2. Confirm that all personnel who are to be involved in the deployment are aware of what frequency is represented by each LED bar graph colour.
3. For optimum results keep sources of electrical noise such as laptops, computers, radios, mobile telephones, electrical motors, electrical valves etc as far away from the receiver as possible to minimise unwanted noise.
4. For optimum results keep any magnetic items in the vicinity of the receiver such as steel toecaps, steel tools, magnets, vehicles etc as still as possible relative to the receiver to minimise unwanted noise. If possible, remove them from the vicinity of the receiver.
5. For optimum results do not vibrate, knock or move the receiver excessively while attempting to receive signals. This causes false signals due to the receiver moving in the earth's magnetic field. Keep any movements slow and smooth. The receiver should be placed stationary on the pipe surface or on the ground whenever possible and particularly when attempting to receive very weak signals.
6. In an ideal, electrically quiet environment and with the receiver stationary on the ground it should be possible to set gain to maximum and have no signal registered on any LED bar graph. Unfortunately, most industrial environments are electrically noisy.
7. If received noise is not illuminating any LEDs, then the gain may be too low. Increase gain to keep received noise around 2x LEDs (10%).
8. If the received signal is regularly exceeding 18x LEDs (90%) then the gain is too high. Adjust gain to keep the received signal between 50% and 90% deflection.
9. Look out for potential problems due to excessively large signals. See 4.11 ANDROID EXCESSIVELY LARGE INPUT WARNING and 5.11 WINDOWS EXCESSIVELY LARGE INPUT WARNING.
10. If unsure about a signal's legitimacy, move the receiver away from the transmitter. A sharp signal drop indicates a legitimate transmitter; a stable signal suggests noise. Signal strength decreases by a factor of eight when the distance is doubled due to the cubic relationship between distance and signal.

3.4. TURNING ON

1. To turn the receiver on, fully depress and hold the control button until all LED bar graphs illuminate from left hand side to right hand side (approximately 5 seconds).
2. Keep the control button depressed to display the frequency configuration of each of the 3x LED bar graphs as shown in the example image below. To determine the frequency configuration simply count the number of LEDs illuminated on each half of each bar graph. In the example below the 3x frequencies are configured as (1 | 7) 17Hz, (2 | 2) 22Hz and (3 | 0) 30Hz respectively.

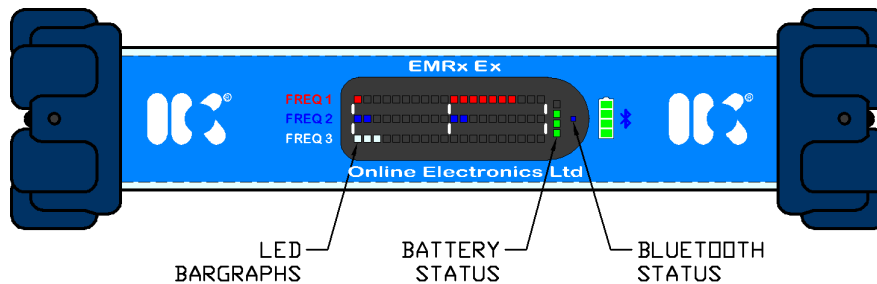

3. Release the control button.
4. Confirm that all personnel who are to be involved in the deployment are aware of what frequency is represented by each LED bar graph colour. Confirm the frequencies are configured as required for the deployment. These frequencies can be changed as described in sections 4 EMRx ANDROID APPLICATION and 5 EMRx WINDOWS APPLICATION.
5. Confirm that at least 3 out of 4 of the green battery status LEDs are illuminated indicating that at least 75% battery lifetime is available. If less than 3 out of 4 of the green battery status LEDs are illuminated, then consider changing the batteries as per 3.8 BATTERY REPLACEMENT.
6. Confirm that a suitable gain setting has been selected and complete a function test as per 3.9 FUNCTION TEST.
7. Confirm that the Bluetooth status LED is flashing once every second indicating that the Bluetooth interface is active and advertising for a connection. If no connection is made within 5 minutes the Bluetooth interface will go to sleep to conserve battery life. To wake the Bluetooth interface for another 5 minutes, press the control button once.

3.5. MEASUREMENT DISPLAY

The EMRx can be configured such that all 3 rows of LEDs will display the signal strength of the EM frequencies configured for each row, adjusted in magnitude by the gain setting.

The top row of LEDs can alternatively be configured to display MAGNETIC field strength. A threshold can also be configured (default 35milli-Gauss). The 10th LED on the top row corresponds to the value of the magnetic flux threshold set. Therefore, with the default magnetic threshold of 35mG each LED corresponds to ~3.5mG.

When a magnetic field > magnetic threshold is detected the top row of LED will flash for ~5 seconds or remain alight until the magnetic flux falls below the magnetic threshold.

When the first row of LEDs is configured for magnetic measurement the frequency 'gain cursor' measurements is not displayed on the first row of LEDs. This provides an indication that the top row is configured for magnetic flux display level.

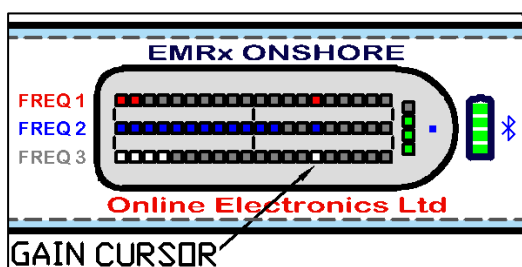

All 3 rows showing frequency

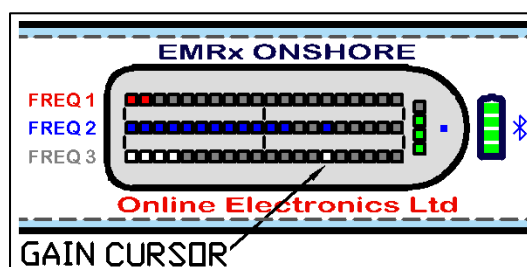

Top row magnetic. Second & third row frequency

3.6. GAIN ADJUSTMENT

1. To adjust gain upwards use short (approximately 0.5 seconds long) presses of the control button to increment gain setting along the LED bar graphs from left to right.
2. To adjust gain downwards use long (approximately 1.0 seconds long) presses of the control button to decrement gain setting along the LED bar graphs from right to left.
3. There are 20x possible settings displayed by a vertical line across all three 20x LED bar graphs. Minimum gain setting is on the extreme left of the LED bar graphs. Maximum gain setting is on the extreme right of the LED bar graphs.
4. Each gain step applies a factor of approximately 1.6 to the number of signal LEDs currently illuminated. E.g. if there are currently 10 LEDs illuminated and gain is increased one step then $10 \times 1.6 = 16$ LEDs will become illuminated. Alternatively if there are currently 10 LEDs illuminated and gain is decreased one step then $10 / 1.6 = 6$ LEDs will become illuminated.
5. If the gain setting is already at maximum (on the extreme right of the LED bar graphs) then the next short button press will wrap around to the minimum gain setting (on the extreme left of the LED bar graphs) and vice versa.
6. Sections 4 EMRx ANDROID APPLICATION and 5 EMRx WINDOWS APPLICATION describe how the gain can be controlled using the EMRx applications.

3.7. TURNING OFF

1. To turn the receiver off, fully depress and hold the control button until all LED bar graphs illuminate from right hand side to left hand side (approximately 5 seconds).
2. Release the control button.
3. Confirm that no LEDs are illuminated.
4. Always turn the unit off using this method to preserve the latest changes made to any settings.

3.8. FREQUENCY AND MAGNETIC THRESHOLD

3.8.1. MANUAL ADJUSTMENT

The top row of LEDs on EMRx receiver can display either a specific frequency or magnetic flux measurement. The middle and bottom row of LEDs can only be configured to display specific frequency measurements.

To change the frequency and/or magnetic threshold configuration manually without access to or using the mobile device application.

1. Turn the receiver off, if currently turned on.
2. Turn the receiver on (Section 3.4 TURNING ON steps 1-4) releasing the control button when the frequency is displayed. When the strips alight press and hold the control button for 5 seconds. Whilst the control button is held the LEDs will display the current configuration. If the control button is released before 5 seconds the unit enters normal mode of operation.
3. Whilst the control button is held, and after 5 seconds, the battery status LEDs will turn off and the LEDs will flash with the current configuration.
4. Release the control button. The LEDs will continue to flash for approximately 3 seconds with the current configuration.
5. The LEDs will then show a flashing symbol approximating in appearance to an 'F' or 'M' character representing 'FREQUENCY' or 'MAGNETIC'. This configures the type of measurement for the top row of LEDs.
6. Briefly press the control button, if necessary, to toggle this value to select the required measurement type for the top row of LEDs.
7. The top row of LEDs will then display the current frequency or magnetic threshold set for that row with the left 10 LEDs flashing with a value representing the decade value. E.g. if the current configuration has a value of 27 then the decade value will be '2' and two LEDs will flash. The 7 LEDs on the right side representing units will remain static.
8. Briefly press the control button to change the decade value to the required setting. If zero is selected all 10 LEDs flash.
9. Once the required decade value has been set wait 5 seconds where upon the LEDs on the righthand side, representing the units, will flash. These are configured as per the previous step.

10. Once the units are configured the next LED row will flash and is configured as per steps 7 – 9 above.
11. Only frequency settings configured between 10 – 30 Hz and magnetic threshold > 5 (milli-Gauss) will be saved.
12. The unit will then check the values entered and save if valid.

3.8.2. SOFTWARE ADJUSTMENT

1. The magnetic threshold can be adjusted within the software application on the settings section under the "Hardware Configure" table. Threshold settings can be entered with a value between 5 and 99 milli-Gauss.

3.9. FUNCTION TEST

3.9.1. EM FUNCTION

At least 24 hours prior to deployment any personnel who are going to be involved in the operation of the receiver should review this entire manual and be given time to practice operating the transmitter and receiver system. By familiarising themselves with the system prior to deployment the chances of a potentially costly operator error are greatly reduced.

1. Turn on the receiver as per 3.4 TURNING ON.
2. Place the receiver stationary on the ground.
3. With no transmitter activated adjust gain as per 3.6 GAIN ADJUSTMENT to achieve approximately 2x LEDs (10%) illuminated on all bar graphs (assuming that the receiver is in a typical, electrically quiet, environment). If gain at this point is less than half, then it indicates that there is a source of electromagnetic noise nearby and the receiver should be moved away from the noise source if possible. If it is not possible to remove the noise source, then it must be accepted that the noise source is going to reduce the detectability of any transmitter at that frequency in the vicinity.
4. In an ideal, electrically quiet environment and with the receiver stationary on the ground it should be possible to set gain to maximum and have no signal registered on any LED bar graph. Unfortunately, most industrial environments are electrically noisy.
5. Gently bump the receiver with your hand. This should cause peaks in the received signal and gives a basic confirmation that the equipment is functional. These peaks are due to the receiver moving in the earth's magnetic field and demonstrate why it is important not to shake or vibrate the receiver when you are trying to use it to detect relatively weak signals. Always keep the receiver as still as possible, any movements should be slow and smooth.
6. Pick up the receiver and gently shake it. This should cause peaks in the received signal due to the receiver moving in the earth's magnetic field.
7. If available a test transmitter of suitable frequency should always be used to confirm full functionality. If a test transmitter is available then practice detecting the test transmitter as described in 3.10 APPROXIMATE TRANSMITTER LOCATION and 3.11 ACCURATE TRANSMITTER POSITION. If testing a transmitter in air remember that the signal received will be much larger than the signal which would be received from the same transmitter inside a pig inside a pipeline.

8. If applicable, familiarise yourself with the EMRx applications as per sections 4 EMRx ANDROID APPLICATION and 5 EMRx WINDOWS APPLICATION.

3.9.2. MAGNETIC FUNCTION

1. Turn on the receiver as per 3.4 TURNING ON.
2. Place the receiver stationary on the ground.
3. With the receiver set to display "Magnetic" as per 3.8 FREQUENCY AND MAGNETIC THRESHOLD, take a magnet and when it approaches the receiver, the top row of LEDs will begin to light up. The closer the magnet is, the more LEDs will appear. When a strong enough signal is detected, the top row will flash. To reset the lights, take the magnet away from the receiver until the row of LEDs stop flashing and slowly decrease the amount light up.
4. The EMRx WINDOWS APPLICATION can display a graph using a separate axis indicating the amount of signal being detected with the magnet in the same way the EM displays. This can be activated and deactivated using a check box on the frequency legend under the signal section of the application.

3.10. APPROXIMATE TRANSMITTER LOCATION

The typical procedure for determining the approximate position of an electromagnetic transmitter is given below.

1. Turn on the receiver as per 3.4 TURNING ON.
2. Place the receiver stationary on the ground at least 10m from the expected location of the transmitter. At this range it is expected that the signal received from the transmitter will be negligible and any signal you do detect is background noise.
3. Increase the gain to the maximum setting possible without allowing the background noise level to illuminate more than 2x LEDs (10%) on the bar graph. The optimum background noise level for identifying an EM signal is typically 2x LEDs (10%) or less. It will be extremely difficult to detect a signal if the background noise level is more than 50%. If the background noise is more than 50% then the receiver gain must be reduced or the source for the excessive background noise must be identified and removed. Note that more gain is not always best, if there is significant background noise and the gain is too high then the transmitter signal may be hidden by the background noise.
4. In an ideal, electrically quiet environment and with the receiver stationary on the ground it should be possible to set gain to maximum and have no signal registered on any LED bar graph. Unfortunately, most industrial environments are electrically noisy.
5. Now gradually move the receiver towards the expected location of the transmitter keeping the receiver orientated parallel to the expected transmitter orientation as shown to maximise received signal and range. If the transmitter is at the expected location, then the received signal should rise significantly.

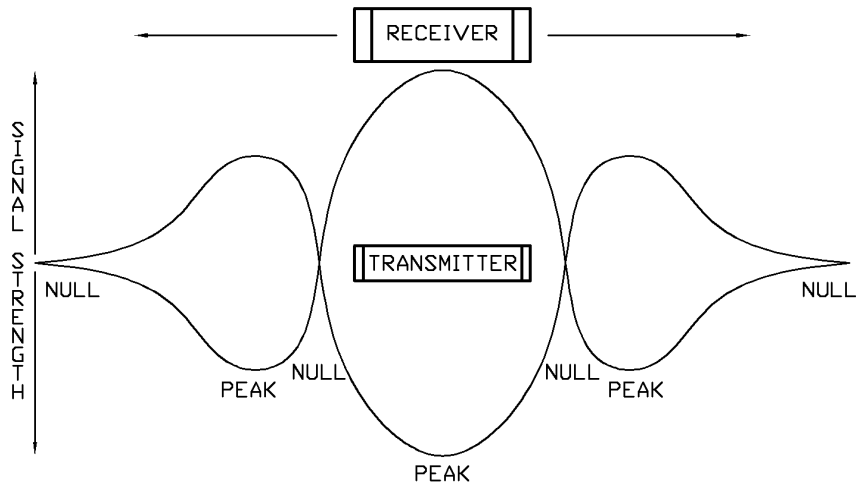

6. If the received signal is extremely weak then the receiver gain will need to be high and the receiver must be held as still as possible and as close as possible to the pipeline surface. Ideally it should be balanced on top of the pipeline surface or placed on the ground as close as possible to the pipeline.
7. If the transmitter is in pulsing mode confirm that the expected pulse rate is being received.
8. Keeping the receiver parallel to the pipeline step slowly and methodically along the pipeline (keeping a constant distance between the receiver and the pipeline surface) while watching the received signal to determine which direction results in an increasing signal. Keep moving in this direction until a peak in signal is received which will occur at the approximate position of the transmitter. Gain should be reduced whenever the received signal exceeds approximately 18x LEDs (90%).
9. If the signal is strong and clear, then it should be possible to find this peak by following the pipeline keeping the receiver as still as possible. If the signal is weak and difficult to detect without high gain, then it is usually best to periodically place the receiver stationary on top of the pipeline at 1m intervals to prevent false signals caused by movement of the receiver. A 1m interval is typical but may be increased or decreased depending on whether a strong or weak signal is expected.
10. Once a peak has been found confirm that if the receiver is moved away from the transmitter in any direction (along the pipeline or away from the pipeline) that the received signal drops.
11. Once the approximate transmitter location has been established refer to 3.11 ACCURATE TRANSMITTER POSITION if a more accurate location is required.

3.11. ACCURATE TRANSMITTER POSITION

Establish the approximate transmitter location as per section 3.10 APPROXIMATE TRANSMITTER LOCATION before attempting to establish a more accurate location. The perpendicular receiver orientation used to establish the accurate transmitter location is not suitable for searching for the approximate transmitter location due to the relative insensitivity of this orientation.

1. Once the approximate location of the transmitter has been determined turn the receiver 90° so that it is perpendicular to the transmitter as shown.

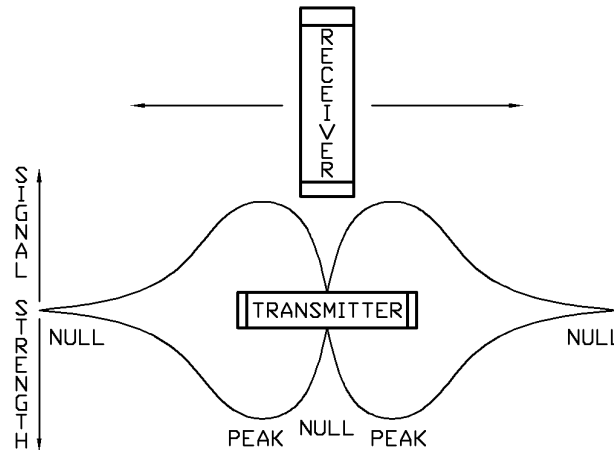

2. Typically, the receiver should be held stationary approximately 1m from the pipeline surface however this distance may need to be reduced or increased depending on how weak or strong the received signal is respectively.
3. If received signal is above 90% at the peaks, then reduce gain and/or move away from the pipeline to reduce received signal.
4. Maintain the separation and orientation and slowly and methodically step the receiver along the pipeline in either direction from the approximate transmitter location. The received signal should drop significantly as you pass the inherent 'null spot' of the transmitter which occurs when the perpendicular receiver is pointing at the centre of the transmitter. Moving just a few centimetres ahead or behind this point will cause a relatively large and sudden increase in signal.
5. This configuration can be used for centimetre accurate transmitter location. If the null spot cannot be found, then try increasing the distance between the transmitter and receiver and/or reducing gain. Remember that the signal received from a transmitter in a pig inside a pipeline is going to be significantly less than the signal received from a transmitter in air.
6. In a situation where a particularly weak signal is being received it may not be possible to detect the accurate location of the transmitter using this method however if this is the case then the results of the approximate transmitter location will usually be a relatively narrow, well defined peak giving a relatively accurate location for the transmitter.

3.12. BATTERY REPLACEMENT

The battery indicator consists of 4, green, LEDs. If total battery voltage is greater than 9.0V (1.5V per cell) all LEDs will be illuminated indicating the batteries are near full. If total battery voltage is less than 6.0V (1.0V per cell) then no LEDs will be illuminated indicating that the batteries are near empty and must be replaced as soon as possible.

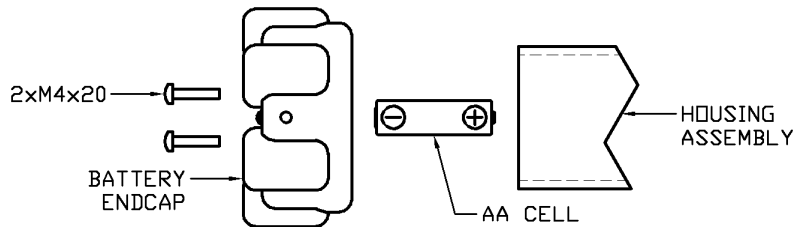

1. Observe the warnings at the start of 3 OPERATION.
2. Turn off the unit as per 3.7 TURNING OFF.
3. If the unit has been exposed to liquids then there is a risk that liquid may drip from the exterior into the interior during endcap removal. Thoroughly dry the exterior before opening and point the end to be opened downwards during opening to allow any trapped liquid to drain out of and not into the equipment.
4. Turn off the unit as per 3.7 TURNING OFF.
5. The batteries are replaced by removing the battery endcap which is identified on the rear of the receiver with the words "BATTERY REPLACEMENT". Never attempt to remove the endcap which has the control button mounted on it and is identified on the rear of the receiver with the words "DO NOT REMOVE".
6. Using a Phillips screwdriver remove the 2x M4x20 self-sealing screws holding the endcap in place.
7. Remove the endcap. Ensure that the O-ring remains within the endcap O-ring groove. Ensure that the endcap and O-ring are placed somewhere clean and tidy to prevent the endcap or O-ring being damaged or contaminated.
8. Remove all 6x AA cells. Visually inspect the cells, contact IK Trax immediately if there are any signs of damage or electrolyte leakage. Dispose of them in a responsible way.
9. Observing correct battery orientation as indicated on the rear of the receiver, insert 6x, new, identical, 1.5V, AA sized, cells into the battery compartment positive end (nipple, +) first. See 9 CERTIFICATION APPENDIX for allowable battery types.
10. Once all cells are installed ensure that it is the negative end (flat, -) of the cells which you see when looking into the open end of the receiver.
11. Examine the endcap O-ring seal for any signs of contamination or damage, clean and/or replace and/or re-grease if necessary.
12. Replace the endcap noting that there is a 3mm locating dowel to ensure correct orientation.

13.  Damage may occur if over tightened - Check Torque setting before installing screws. Fit 2x M4x20 self-sealing screws in Battery Endcap and make-up until screw head is flush with Endcap. Torque screws evenly to 1.0Nm to compress O-ring.
14. Turn the unit on and complete a quick function test as per 3.4 TURNING ON and 3.9 FUNCTION TEST. If the unit is not going to be used immediately then turn off as per 3.7 TURNING OFF.

4. EMRx ANDROID APPLICATION

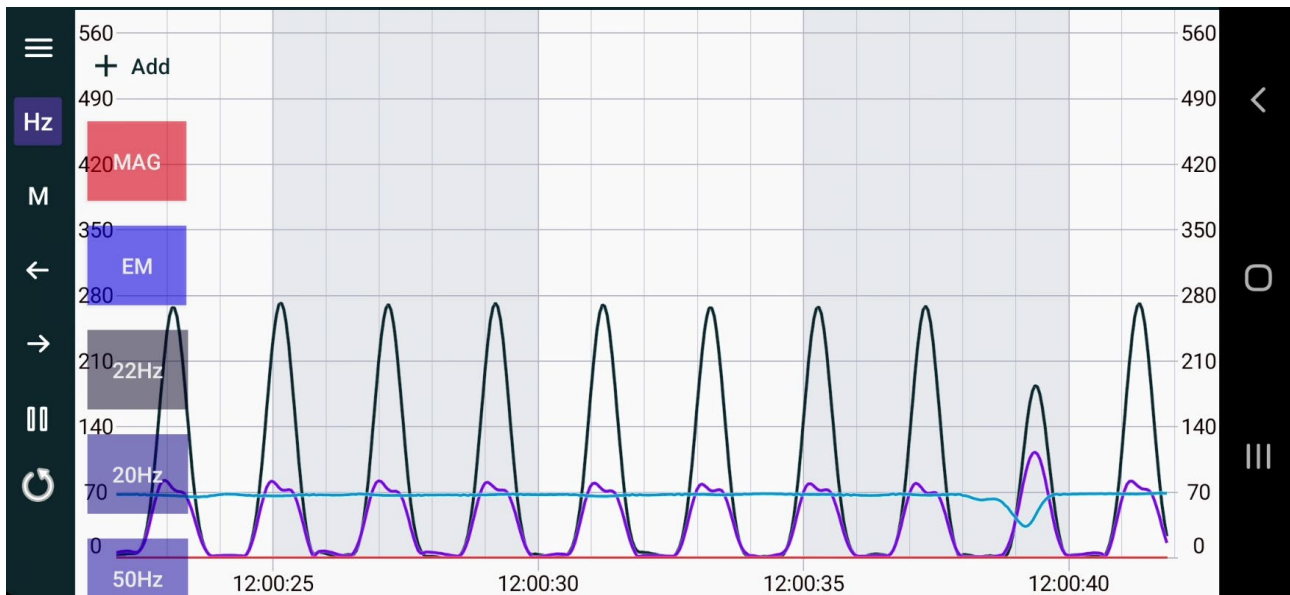

4.1. ANDROID USAGE CONSIDERATIONS

The EMRx application may place a significant performance burden on the host device. To ensure best performance and data integrity the following measures should be observed where possible:

1. Enable "Flight Mode" and/or disable Wi-Fi (Bluetooth must be enabled).
2. Close all other applications and ensure nothing is running in the background.
3. Keep any other activities such as phone calls or messages to a minimum.

It is highly recommended to test the EMRx application performance on the intended host device prior to deployment to confirm the host device is capable of running the application. For critical tracking jobs it is recommended to use a dedicated host device.

The Android operating system requires Location permissions in order to scan for and connect to Bluetooth devices. Ensure that the application has been allowed Location permissions (normally found under Settings> Apps> EMRx> Permissions> Location). In addition, some devices will also need Location services to be enabled (normally found under Settings> Location). Once an EMRx has been connected Location services may be disabled if desired. The EMRx application does not use, record or report Location information.

4.2. ANDROID INSTALLATION

The EMRX android application can be downloaded from the Google app store.

1. Open the google app store and search for the EMRX app.
2. From the search results locate the EMRX app. It can be identified by its logo.

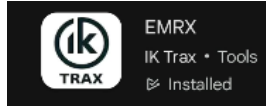

3. Ensure that the app you are downloading matches the one described in this section to avoid downloading a similar-looking app.
4. On the app's page, tap the 'Install' button to begin the installation. Once installed, the app can be accessed by tapping the 'Open' button on the app page, or by locating and launching it on your device.

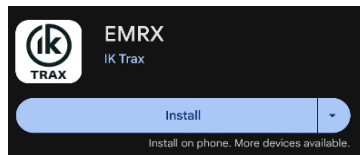

5. The app page also contains the app description and screenshots.

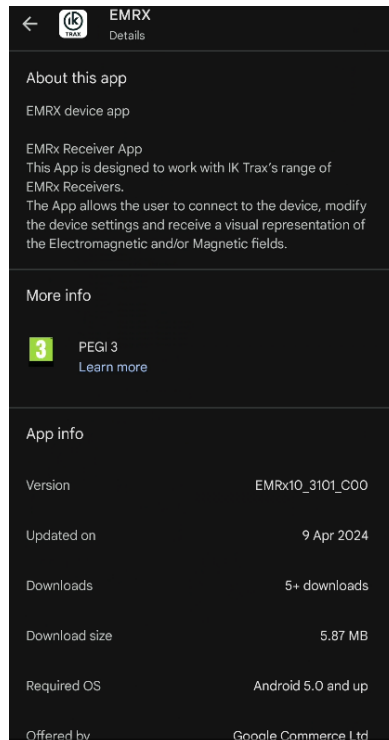

6. Please leave a review. Monitoring user experiences helps improve the application.

4.3. ANDROID ESTABLISHING BLUETOOTH CONNECTION

A connection between the EMRx unit and the EMRx application can be established by following the procedure below.

Note that the name and location of settings may vary by Android device. For more information contact your device manufacturer.

1. Turn on the EMRx unit as per 3.4 TURNING ON. Confirm that the Bluetooth status LED is flashing once every second indicating the Bluetooth interface is active and advertising for a connection. To wake the Bluetooth interface for another 5 minutes, press the control button once.
2. Ensure Bluetooth is enabled on the host device. This setting can be found in the Quick Settings panel which is revealed by swiping down from the top of the device screen.
3. Open the EMRx application on the host device.
4. Within the EMRx application select Start Tracking.
5. Within the EMRx application select the desired EMRx unit from the available list. The EMRx unit will appear in the list of available devices with name "EMRx (Ex if applicable) ###" where "###" is the serial number of the EMRx unit.
6. Confirm that the EMRx unit Bluetooth status LED starts flashing twice per second indicating that a connection has been established.
7. The application will start displaying data in the Signal chart as per 4.5 ANDROID SIGNAL STRENGTH CHART.

4.4. ANDROID MAIN MENU

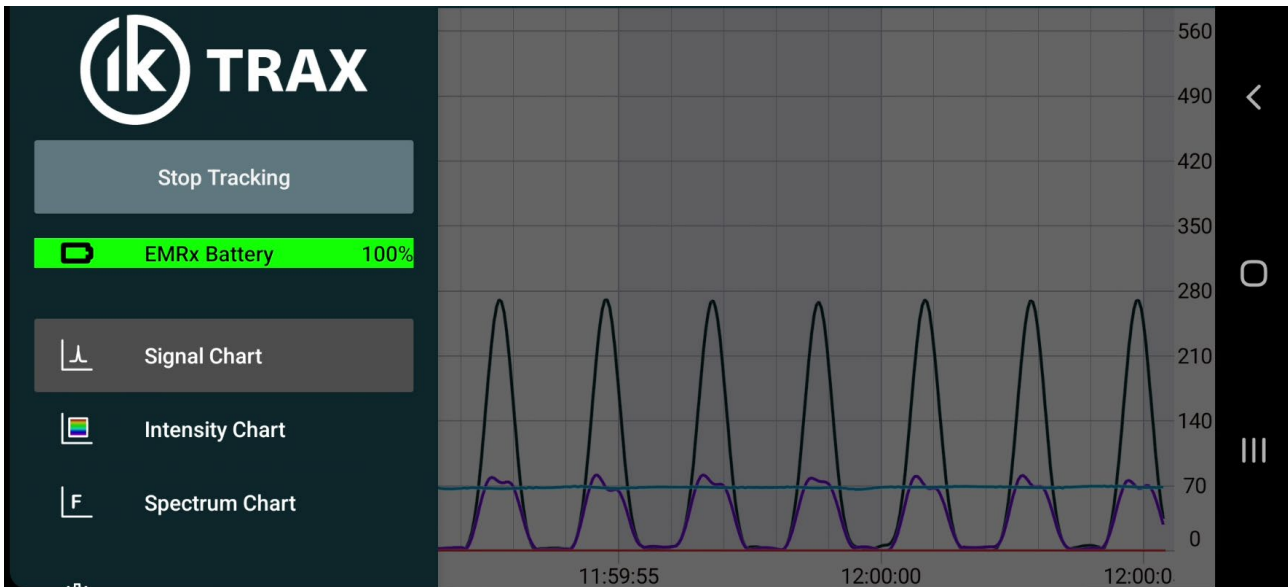

 The main menu has the following controls while connected to an EMRx unit. Only the signal chart control and a close file option are available if looking at a logged file as per 4.10 ANDROID LOGGING.

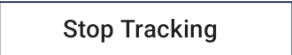
 Stop Tracking Disconnects from the EMRx hardware and saves log file. See 4.10 ANDROID LOGGING.

 EMRx Battery Shows battery status of the connected EMRx hardware in %.

 Signal Chart Selects the signal chart as per 4.5 ANDROID SIGNAL STRENGTH CHART.

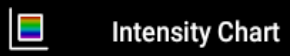
 Intensity Chart Selects the intensity chart as per 4.6 ANDROID INTENSITY CHART.

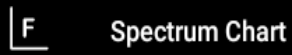
 Spectrum Chart Selects the spectrum chart as per 4.7 ANDROID SPECTRUM CHART.

 Settings Selects the settings menu as per 4.8 ANDROID SETTINGS.

 Audio When Audio is enabled audio tone(s) with amplitude and frequency proportional to received signal are generated for each frequency enabled on the signal chart.

4.5. ANDROID SIGNAL STRENGTH CHART

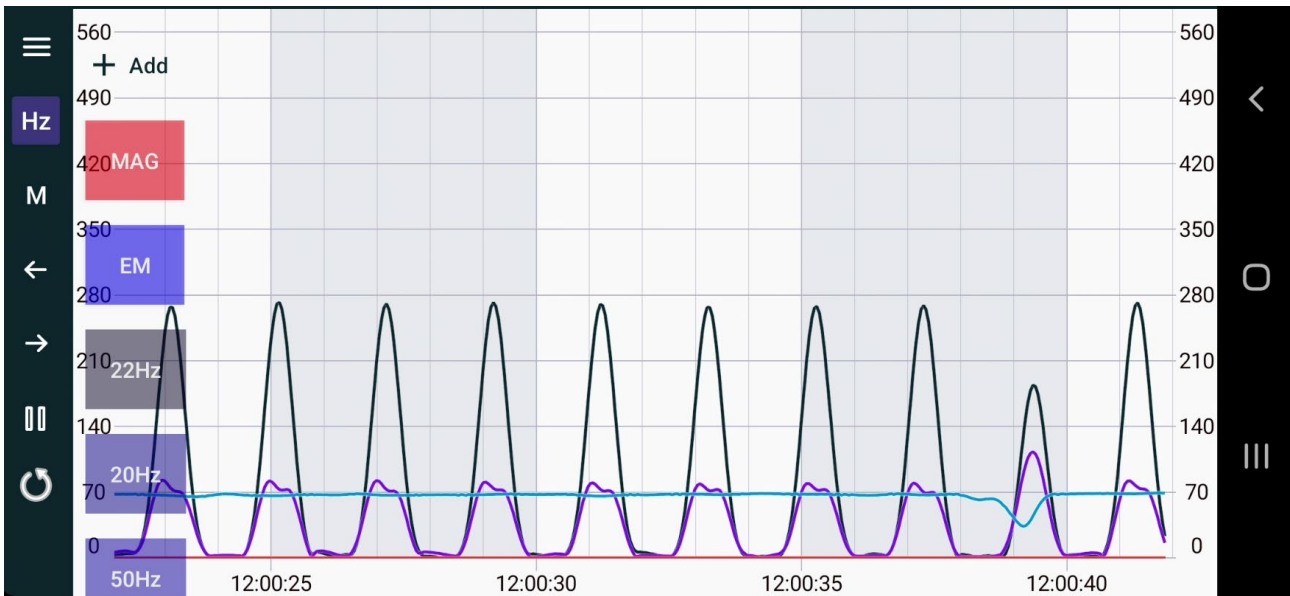

The signal strength chart provides a traditional chart of received signal against time (hh:mm:ss). It is excellent for determining the relative signal strength of up to six colour coded transmitters. Normally the intensity chart (see 4.5 ANDROID SIGNAL STRENGTH CHART) will be used to confirm the frequencies present and then the signal strength chart will be used to determine the accurate signal strength of each frequency.

Touchscreen pinch, drag and fling gestures can be used to zoom and pan as required. Panning is only possible while the chart is paused.



This button opens the main menu as per 4.4 ANDROID MAIN MENU.



This button hides or shows the colour coded frequency boxes. Up to six colour coded frequencies can be added by tapping the +Add button. Frequencies can be altered by tapping the relevant colour coded frequency box.



Place marker button allows placement of a marker. See 4.9 ANDROID MARKERS.



Previous marker button jumps to previous marker. See 4.9 ANDROID MARKERS.



Next marker button jumps to next marker. See 4.9 ANDROID MARKERS.



Alternates between a play and pause button which plays or pauses the chart.



This button resets the screen to latest peak recorded.



This button allows addition of up to 6x colour coded frequencies to the chart. This button can be toggled on or off by tapping the Hz button.



Frequencies can be modified by tapping the relevant colour coded frequency box. These boxes can be toggled on or off by tapping the Hz button.





This button will toggle on or off the Magnetic detection line. **Note:** This will display a line indicating whether or not the EMRx is a Magnetic Detection version. As mentioned in section 4.8 ANDROID SETTINGS you can check if the "Magnetic Threshold" option is greyed out or available to determine if the unit does or does not have this feature.

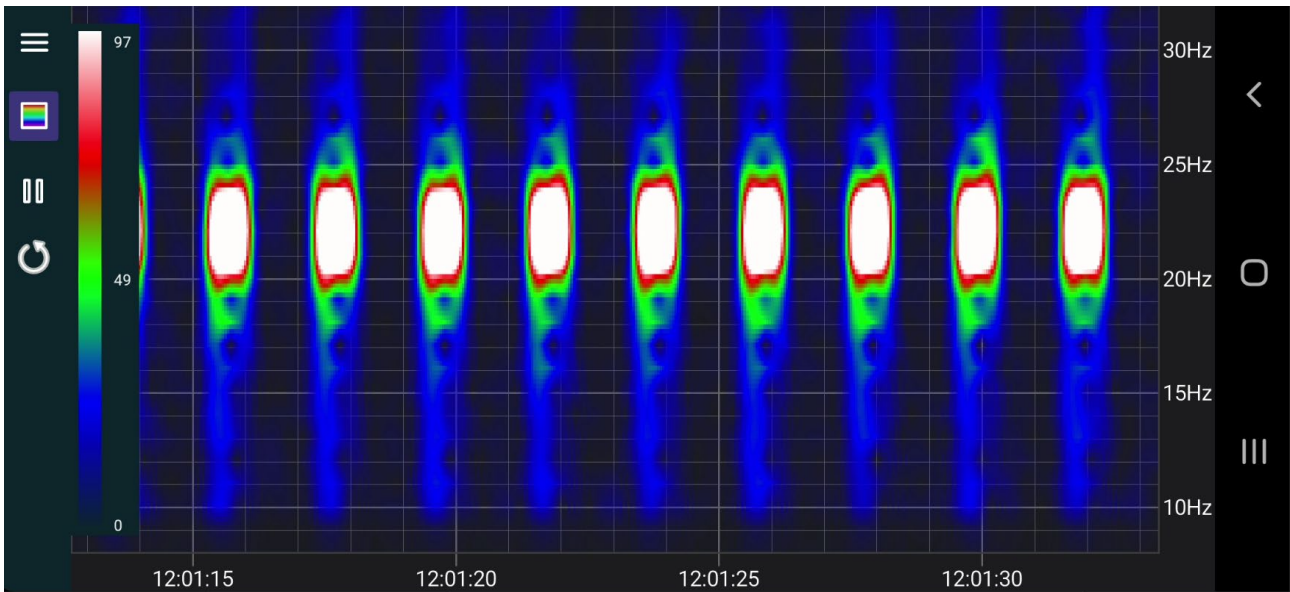

This Button will toggle on or off all of the EM frequencies

4.6. ANDROID INTENSITY CHART



 **Intensity Chart** The intensity chart provides an intuitive representation of the signal strength at all frequencies between 10Hz and 30Hz against time. It is excellent for reliably determining the frequency and pulse rate of one or more transmitters simultaneously. To determine the accurate signal strength of each frequency it is best to use the 4.5 ANDROID SIGNAL STRENGTH CHART.

The horizontal axis of the intensity chart is time (hh:mm:ss) and the right-hand side vertical axis is frequency (Hz). Intensity (signal strength) at each point on the chart is represented by a colour ranging from black (low signal strength) through blue, green and red, to white (high signal strength). The chart constantly scrolls from right to left as new data is received.

An intensity key (vertical bar on left hand axis of the chart with colour gradient going from black at the bottom to white at the top) indicates what signal level each colour represents. In the key shown can see that white represents a signal of approximately 97, red represents a signal strength of approximately 70, green represents a signal of approximately 49, and so on. The scale can be adjusted using vertical drag and fling gestures.

 This button hides or shows the intensity key.

4.7. ANDROID SPECTRUM CHART

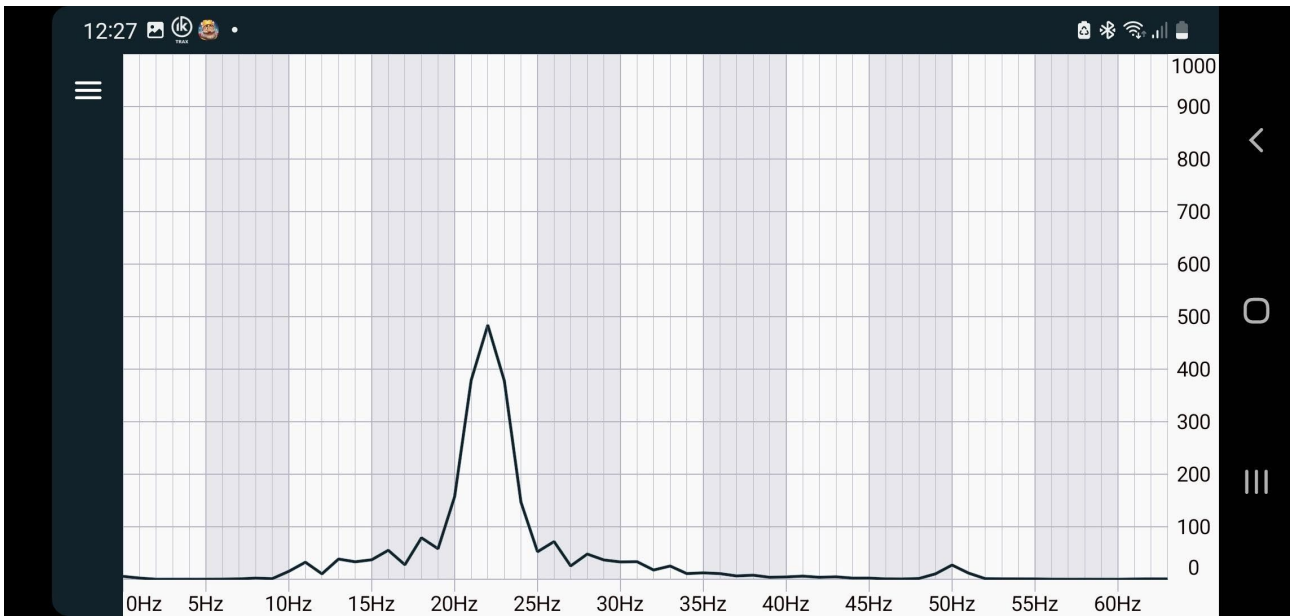

F **Spectrum Chart** The spectrum analyser chart provides a live chart of signal against frequency. It is not usually required for normal EM transmitter reception but can be useful for debug purposes – particularly identifying significant noise sources outside the normal 10Hz to 30Hz range of interest.

The horizontal axis of the spectrum analyser is frequency (Hz) and the vertical axis is relative signal strength. The example shown above shows a strong signal component at 22Hz and a huge noise component at 50Hz. The 50Hz and 60Hz are common noise frequencies due to their use for mains powered equipment and if large enough can compromise reception of signals in the normal 10Hz to 30Hz range and/or cause "clipping" of the input signal as per 4.11 ANDROID EXCESSIVELY LARGE INPUT WARNING.

4.8. ANDROID SETTINGS

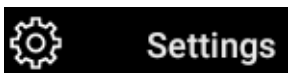
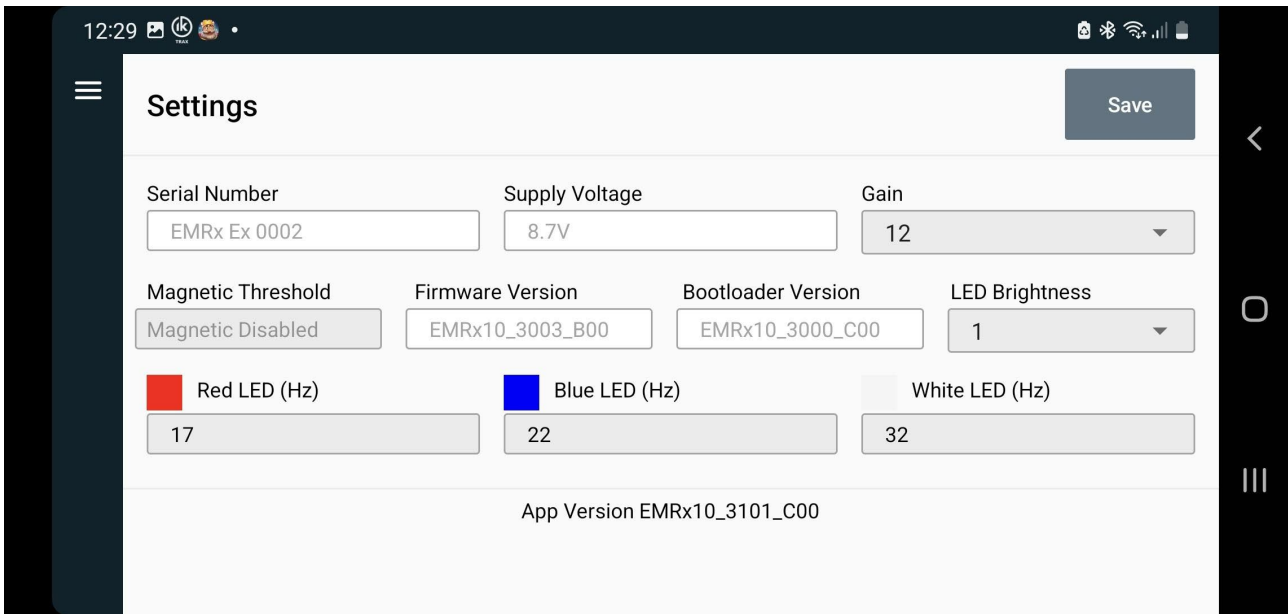

Settings allows configuration of the connected EMRx unit. Once settings have been modified the Save button must be used to save settings to the EMRx unit. Once settings are saved to the EMRx unit they will be remembered even after it has been turned off. A set of hint messages is included in the input fields to advise on the acceptable values.



Saves settings to EMRx unit.

Serial Number	Serial number of connected EMRx unit.
Supply Voltage	Supply Voltage of connected EMRx unit. A reading of 9.0V or more indicates new batteries are installed. A reading of 6.0V or below indicates critically low batteries are installed which should be replaced immediately.
Gain	Gain setting of connected EMRx unit. See 3.6 GAIN ADJUSTMENT.
Magnetic Threshold	Threshold setting for the magnetic field detection. Note: If the Magnetic Threshold box is greyed out with text " <i>Magnetic Disabled</i> ", it indicates that the EMRx (Ex) unit does not have the Magnetic Detection feature.
Firmware Version	Current firmware version of the connected EMRx unit. Note that the firmware can only be updated using the Windows application as per 5.10.4 FIRMWARE CONFIGURE GROUP.
Bootloader Version	Current bootloader version of the connected EMRx unit.
LED Brightness	LED brightness setting of connected EMRx unit. Available settings are from 1 (lowest LED brightness) to 6 (highest LED brightness). Increasing LED brightness will reduce battery lifetime, so it is recommended that this setting is left at the default setting of 1 (minimum) whenever possible.

 Red LED (Hz)

Frequency 1 setting (Hz) of Red LED bar graph.

 Blue LED (Hz)

Frequency 2 setting (Hz) of Blue LED bar graph.

 White LED (Hz)

Frequency 3 setting (Hz) of White LED bar graph.

App Version

Application version. This information can also be found by tapping and holding the application icon and then tapping App info.

4.9. ANDROID MARKERS

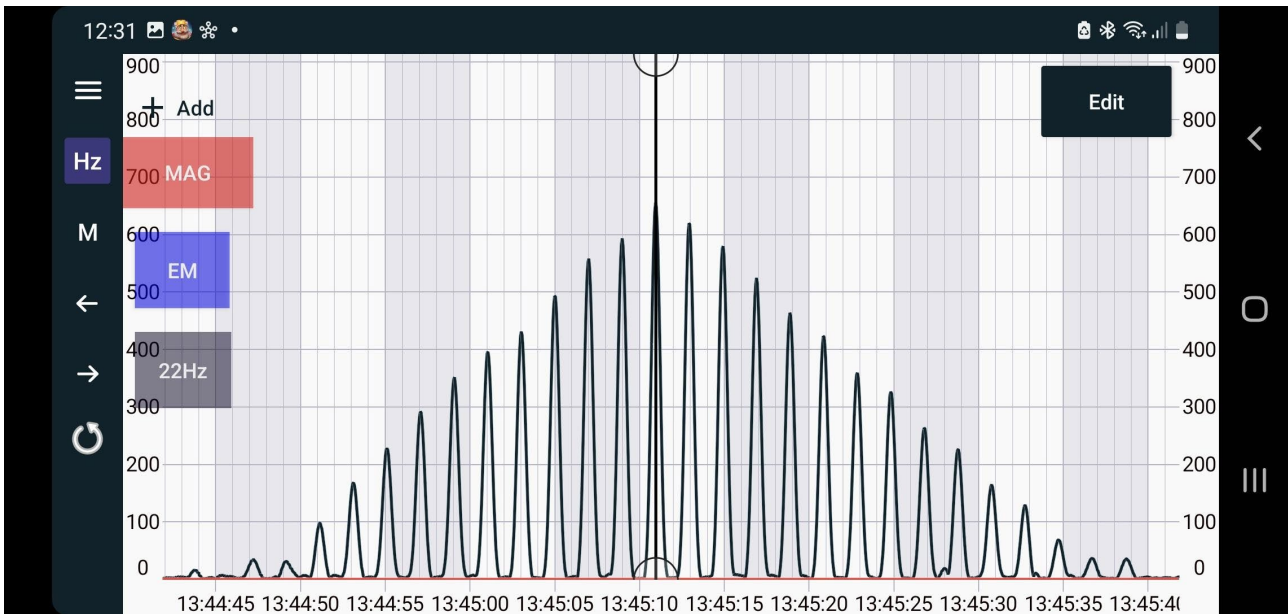

Markers and marker controls are available in the signal chart as shown above. Markers can be placed at points of interest as per 4.9.1 PLACING A MARKER. Once one or more markers have been placed the user can navigate between markers as per 4.9.2 NAVIGATING BETWEEN MARKERS or add notes to markers as per 4.9.4 ADDING NOTES TO A MARKER.

4.9.1. PLACING A MARKER

M Tap this button once to highlight the M and then tap anywhere on the chart to place a marker. Marker appears as a bold vertical line as shown in the image above.

4.9.2. NAVIGATING BETWEEN MARKERS

← Previous marker button jumps to the previous marker, while paused.

→ Next marker button jumps to the next marker, while paused.

4.9.3. MOVING A MARKER

Select the marker by tapping on it once. A circle will appear at the top and bottom of the marker vertical line indicating that it has been selected. The marker can now be dragged to a new location.

4.9.4. ADDING NOTES TO A MARKER

Select the marker by tapping on it once. A circle will appear at the top and bottom of the marker vertical line indicating that it has been selected. An Edit button will appear on the chart at the top right-hand corner.

Tapping the Edit button will open a new screen where Pig ID or Notes can be added to the marker as shown below.

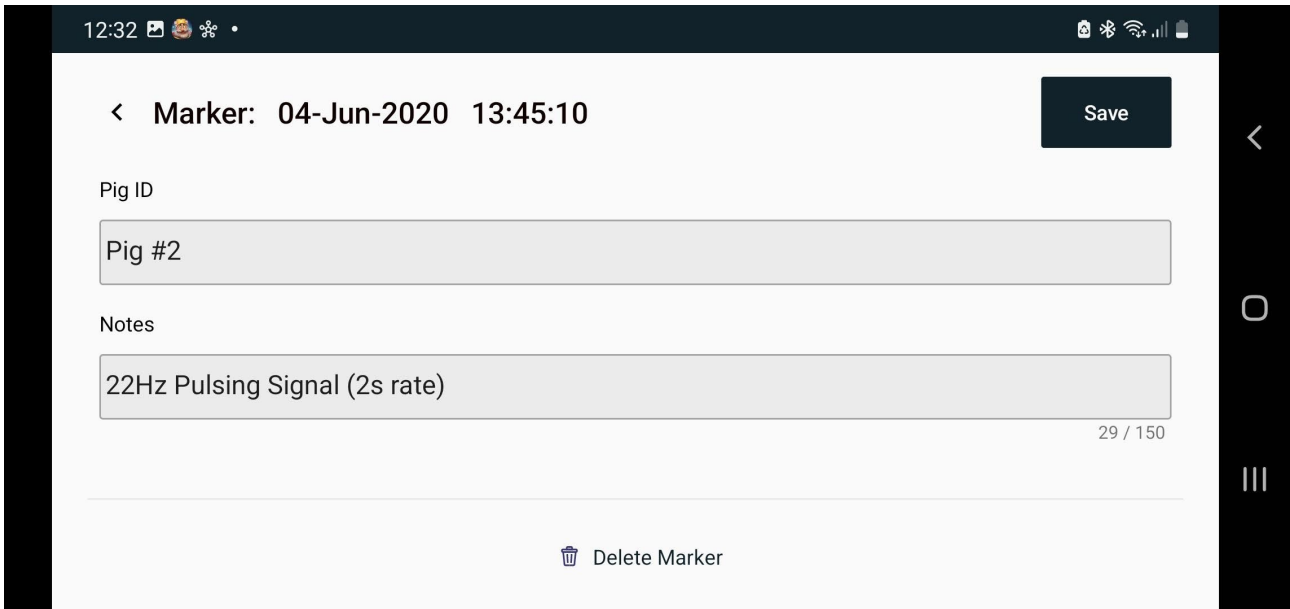

The screenshot shows a mobile application interface for editing a marker. At the top, the status bar displays the time 12:32 and various system icons. The app header shows a back arrow, the text 'Marker: 04-Jun-2020 13:45:10', and a 'Save' button. Below the header, there are two input fields: 'Pig ID' containing 'Pig #2' and 'Notes' containing '22Hz Pulsing Signal (2s rate)'. A character count '29 / 150' is visible at the bottom right of the notes field. At the bottom center, there is a 'Delete Marker' button with a trash icon. The right side of the screen shows a vertical navigation bar with a back arrow, a home button, and a menu icon.

4.9.5. DELETING A MARKER

Select the marker by tapping on it once. A circle will appear at the top and bottom of the marker vertical line indicating that it has been selected. An Edit button will appear on the chart at the top right-hand corner.

Tapping the Edit button will open a new screen where the marker can be deleted entirely by tapping Delete marker.

4.9.6. EXPORTING DATA LOG FILE

Referring to 4.10 ANDROID LOGGING use the Export button to save logging information as a *.bcn text file on the host device. The app will prompt the user to select the location where the file should be saved. This file can then be located and forwarded by the user using e.g. email.

This *.bcn file can be opened in e.g. Microsoft Excel or Notepad and is simply a list data points from the log that can be used to plot the signal on the Windows App. Refer to section 5.10.1. CONNECTION CONFIGURE GROUP to see how to Load the Data File. ANDROID LOGGING.

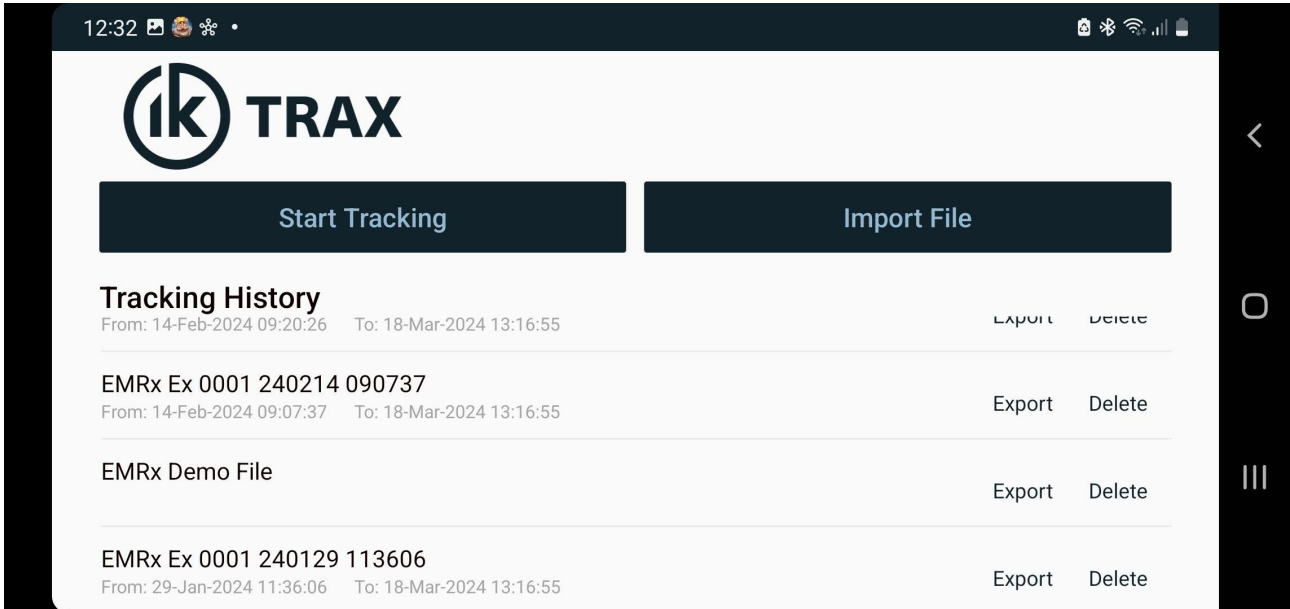

Whenever an EMRx unit is connected a new background log file is created which logs all data received by the application until Stop Tracking is pressed in 4.4 ANDROID MAIN MENU. These files can then be opened and examined at a later date. Typically, these files are stored on the host device at the following location:

[Internal shared storage\Android\data\com.ik_trax.emrx\files](#)

All available log files are listed on the first page of the application as shown above. The first file shown above has filename EMRx Ex 0001 231219 113045 which indicates that it contains data from EMRx (Ex/Onshore) serial number 0001 starting at 11:30:45 on 23/12/2019. The start and end date and time for each log file is shown below each filename.

To open a log file simply tap on the filename on the screen shown above. It may take several seconds to load large files containing more than 30 minutes of data.

Once the file is loaded the user is presented with a signal chart as per 4.5 ANDROID SIGNAL STRENGTH CHART. Up to 6x frequencies may be plotted as normal and all marker functionality is available as per 4.9 ANDROID MARKERS.

Export Exports logging information. See 4.9.6 EXPORTING DATA LOG FILE.

Delete Deletes log file.

Import File

You can Import files from other Android devices or a logged data file from the Windows app to view on the Android device.

4.10. ANDROID EXCESSIVELY LARGE INPUT WARNING

If the gain setting is too high or an excessively large signal or noise is present, or the receiver is being moved excessively then the warning message below may be displayed and the EMRx unit will flash all LEDs to warn of “clipping” of the input signal.

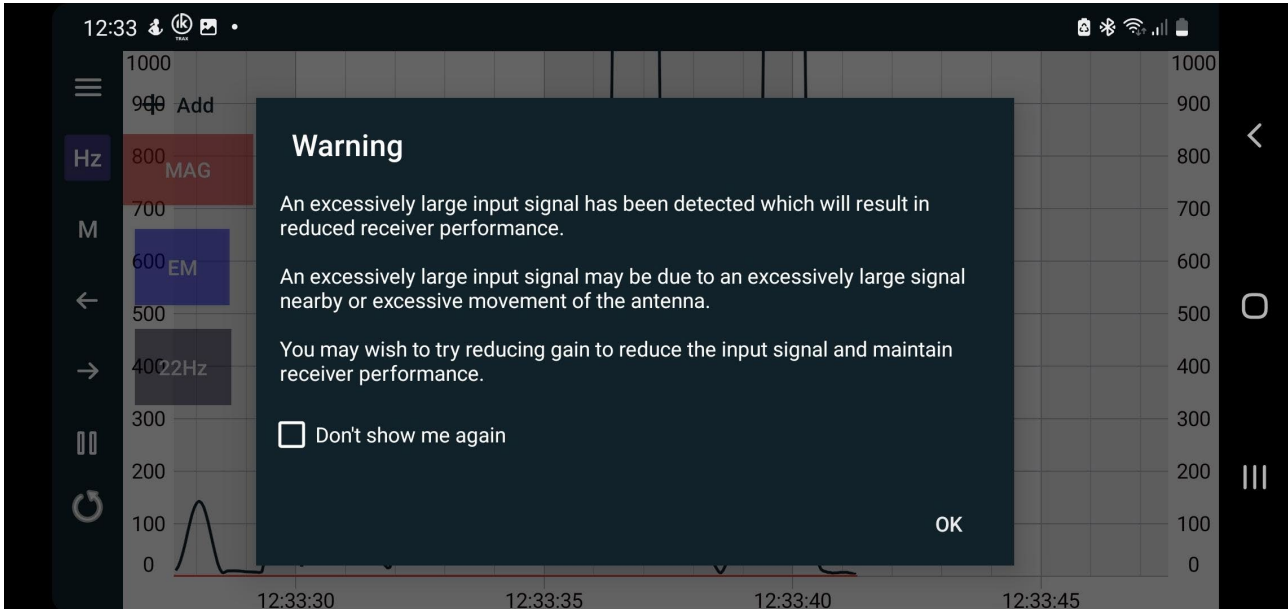

This excessively large signal may not be at a frequency that the user is aware of or expects and is distorting the input signal which results in loss of valid frequency information and generation of spurious frequency information. THE EMRx RECEIVER MUST NEVER BE USED IF THIS IS HAPPENING.

Gain must be reduced, or the receiver must be moved away from the source of the excessively large signal to reduce the signal to a level which does not cause the warning to appear.

See also 5.11 WINDOWS EXCESSIVELY LARGE INPUT WARNING.

4.11. ANDROID SCREENSHOT

At any point while using the application it is possible to capture a screenshot by using one of the standard Android screenshot methods below.

1. Press the power button for a few seconds and then tap Screenshot.
...or...
2. Press and hold the Power and Volume down buttons at the same time for a few seconds.

5. EMRx WINDOWS APPLICATION

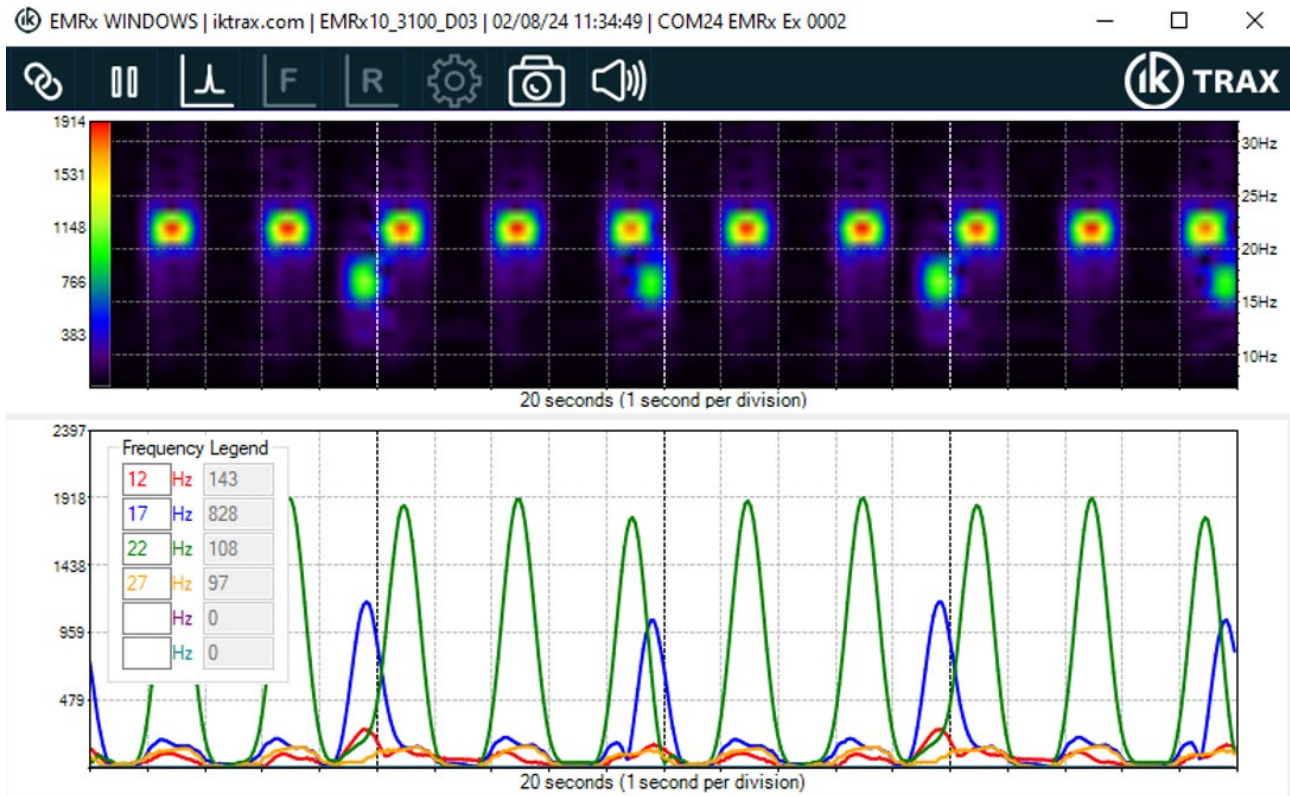

5.1. WINDOWS USAGE CONSIDERATIONS

The EMRx application may place a significant performance burden on the host device. To ensure best performance and data integrity the following measures should be observed where possible:

1. Enable "Flight Mode" and/or disable Wi-Fi (Bluetooth must be enabled).
2. Close all other applications and ensure that nothing else is running in the background.
3. Keep any other activities such as phone calls or messages to a minimum.

It is highly recommended to test the EMRx application performance on the intended host device prior to deployment to confirm the host device is capable of running the application. For critical tracking jobs it is recommended to use a dedicated host device.

5.2. WINDOWS INSTALLATION

The installation folder for the EMRx Windows application has typical name EMRx10_3100_XXX which represents the full application name and version.

The typical size of the installation folder is 2MB.

Simply unzip the folder if applicable, save the folder into any location on the target device, run the setup.exe file, found within the folder, and then follow the instructions when prompted.

Most Windows computers will already have all other necessary software and drivers installed. If not, then download and install the latest available versions of the following software and drivers:

1. Latest compatible .NET framework runtime <https://dotnet.microsoft.com/download>.
2. Latest compatible DirectX Runtime from <https://www.microsoft.com/en-gb/download>.

5.3. WINDOWS BLUETOOTH PAIRING

Before a connection between a particular host device and a particular EMRx unit can be established for the first time the host device must be "paired" with the EMRx unit by following the procedure below.

Pairing between a particular EMRx unit and a particular host device is only required once – once paired the EMRx unit and the host device will remember each other and next time a connection can be established immediately as per 5.4 WINDOWS ESTABLISHING BLUETOOTH CONNECTION.

Note that the name and location of settings may vary by device and operating system. The instructions below are for a typical Windows 10 device.

1. Ensure the EMRx unit is turned off.
2. Ensure that the host device is not in "Flight Mode" and that Bluetooth is enabled. Both of these settings can be found in Start> Settings> Devices.
3. Begin scanning for new Bluetooth devices on the host device by selecting Start> Settings> Devices> +Add Bluetooth or other device > Bluetooth.
4. Turn on the EMRx unit as per 3.2 TURNING ON. Confirm that the Bluetooth status LED is flashing once every second indicating the Bluetooth interface is active and advertising for a connection. If no connection is made within 5 minutes the Bluetooth interface will go to sleep to conserve battery life. To wake the Bluetooth interface for another 5 minutes, press the control button once.
5. After a moment the EMRx unit should appear in the list of visible devices on the host device with name "EMRx ###" where "###" is the serial number of the EMRx unit.
6. Click on the EMRx ### entry on the host device list to pair the host device and the EMRx unit and follow any on-screen steps.

5.4. WINDOWS ESTABLISHING BLUETOOTH CONNECTION

Once paired as per 5.3 WINDOWS BLUETOOTH PAIRING a connection between the EMRx unit and the EMRx application can be established by following the procedure below.

Note that the name and location of settings may vary by device and operating system. The instructions below are for a typical Windows 10 device.

1. Turn on the EMRx unit as per 3.2 TURNING ON. Confirm that the Bluetooth status LED is flashing once every second indicating the Bluetooth interface is active and advertising for a connection. If no connection is made within 5 minutes the Bluetooth interface will go to sleep to conserve battery life. To wake the Bluetooth interface for another 5 minutes, press the control button once.
2. Ensure that the host device is not in "Flight Mode" and that Bluetooth is enabled. Both of these settings can be found in Start> Settings> Devices.
3. Open the EMRx application on the host device.
4. Within the EMRx application Connection Configure group, select the correct device from the Select Device drop down list. The EMRx unit will appear in the list of available devices with name "EMRx ###" where "###" is the serial number of the EMRx unit. Note that all previously paired EMRx units will also appear in this list even if they are not powered or within range.
5. Within the EMRx application Connection Configure group, press the Connect button.
6. Confirm that the EMRx unit Bluetooth status LED starts flashing twice per second indicating that a connection has been established.
7. The application will start displaying data in the Signal chart as per 5.7 WINDOWS SIGNAL STRENGTH CHART.

5.5. WINDOWS RIBBON CONTROLS



The ribbon contains the following controls:



Shows the Connection Configure group as per 1.1.1 .



Pause or play all charts.



Shows the signal strength chart as per 5.7 WINDOWS SIGNAL STRENGTH CHART.



Shows the spectrum chart as per 5.8 WINDOWS SPECTRUM CHART.



Shows the raw signal chart as per 5.9 WINDOWS RAW CHART.



Shows the settings page as per 5.10 WINDOWS SETTINGS.



Captures a screenshot as per 5.12 SCREENSHOT.



Enables or disables audio output. When enabled audio tone(s) with amplitude and frequency proportional to received signal are generated for each frequency enabled on the signal strength chart.

5.6. WINDOWS INTENSITY CHART

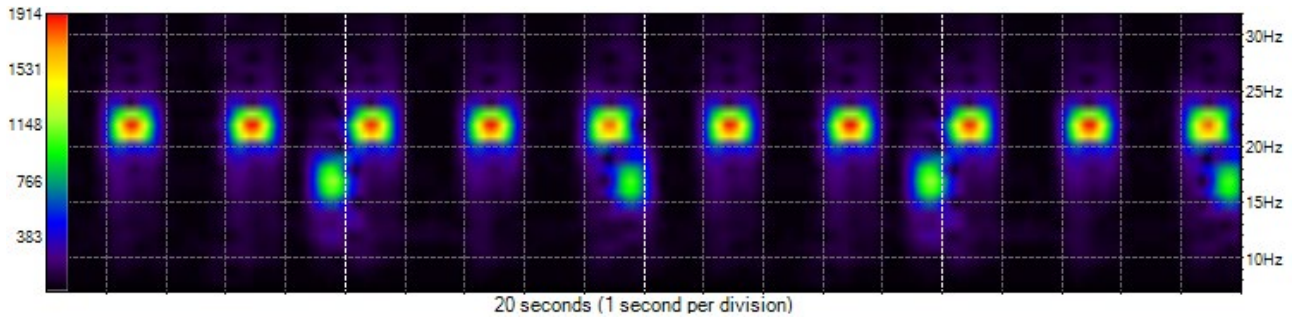

The intensity chart is always shown in the upper half of the main window.

The intensity chart provides an intuitive representation of the signal strength at all frequencies between 10Hz and 30Hz against time. It is excellent for reliably determining the frequency and pulse rate of one or more transmitters simultaneously. To determine the accurate signal strength of each frequency it is best to use the 5.7 WINDOWS SIGNAL STRENGTH CHART.

The horizontal axis of the intensity chart is time (1 second per division) and the right-hand side vertical axis is frequency (Hz). Intensity (signal strength) at each point on the chart is represented by a colour ranging from black (low signal strength) through blue, green and yellow to red (high signal strength). The chart constantly scrolls from right to left as new data is received.

The example shown above shows the typical display while a 22Hz electromagnetic transmitter pulsing once every 2 seconds and a 17Hz electromagnetic transmitter pulsing once every 5 seconds are received simultaneously. It is obvious that one transmitter is at 22Hz because the most intense point of each pulse is aligned with the 22Hz tick mark on the vertical axis on the right-hand side of the chart. It is obvious that the received signal of this transmitter is pulsing every 2 seconds because each pulse is separated by 2 horizontal divisions.

An intensity key (vertical bar on left hand axis of the chart with colour gradient going from black at the bottom to red at the top) indicates what signal level each colour represents. In the key shown can see that red represents a signal of approximately 1900, yellow represents a signal strength of approximately 1500, green represents a signal of approximately 1100, and so on.

The vertical scale can be adjusted by clicking and dragging the mouse up or down anywhere on the chart. If the chart has been clicked previously then you can also use the keyboard up and down arrows. Double clicking on the chart will autozoom to the visible data.

The horizontal scale can be adjusted between 5 seconds and 60 seconds by clicking and dragging the mouse left or right anywhere on the chart.

The main window can be resized like a normal windows application. The individual chart heights can be adjusted by dragging the grey bar immediately below the intensity chart up or down.

5.7. WINDOWS SIGNAL STRENGTH CHART

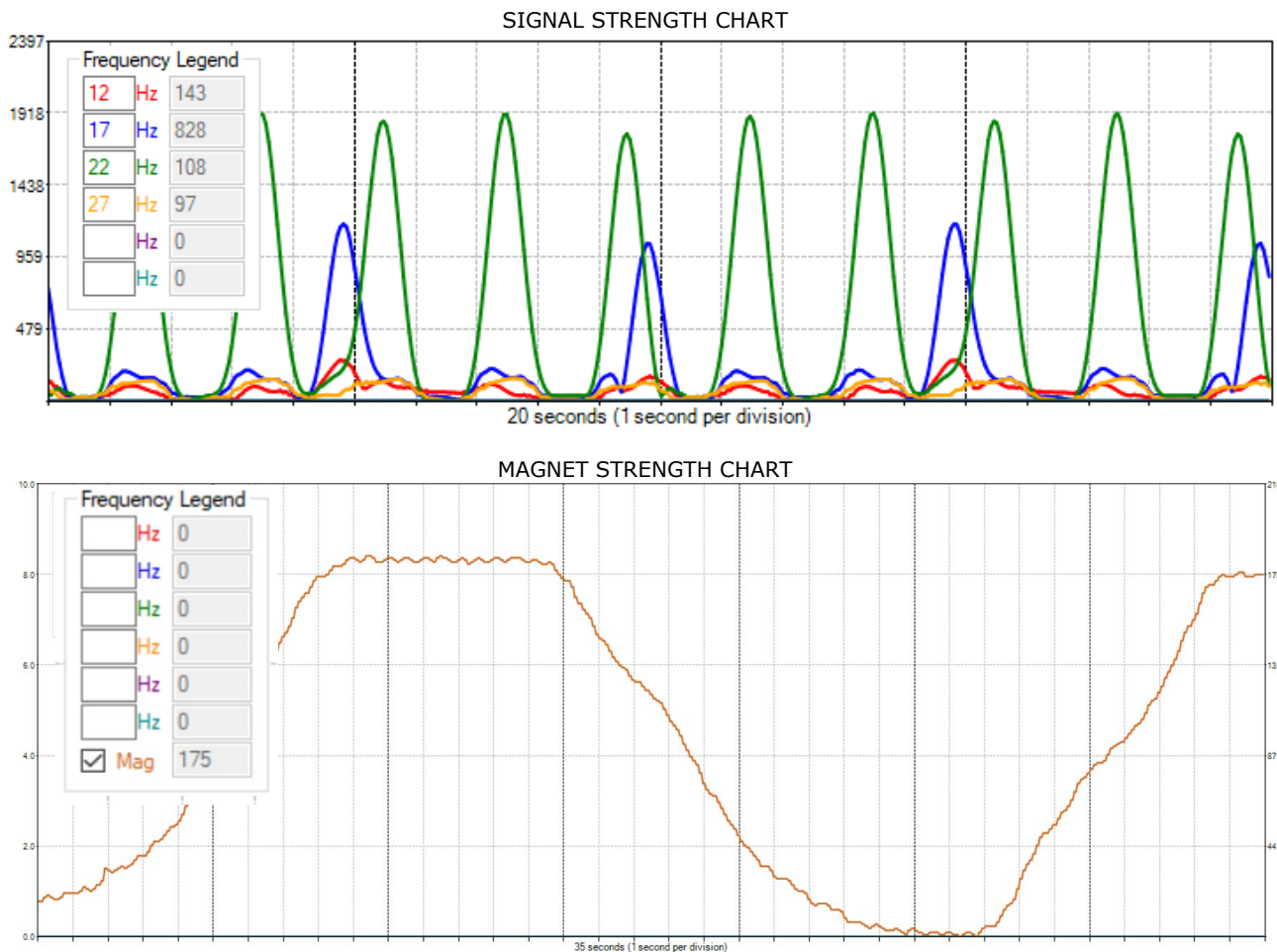

The signal strength chart can be displayed in the lower half of the main window by pressing the relevant icon on the ribbon as per 5.5 WINDOWS RIBBON CONTROLS.

The signal strength chart provides a traditional chart of received signal against time. It is excellent for determining the relative signal strength of up to six colour coded transmitters. Normally the intensity chart (see 5.6 WINDOWS INTENSITY CHART) will be used to confirm the frequencies present and then the signal strength chart will be used to determine the accurate signal strength of each frequency.

The signal strength chart example shown above shows the typical display while both a 22Hz electromagnetic transmitter pulsing once every 2 seconds and a 17Hz electromagnetic transmitter pulsing once every 5 seconds are received simultaneously. Using the signal strength chart, it is not necessarily obvious what frequencies the transmitters are transmitting at – the intensity chart should be used to determine this. In the example shown above can see that the received signals are pulsing every 2 seconds and every 5 seconds because the pulses are separated by 2 and 5 horizontal divisions (which are fixed at 1 second apart) respectively. From the vertical axis on the right-hand side can see that the signal strength of each 22Hz pulse is approximately 1900 and the signal strength of each 17Hz pulse is approximately 1100. The vertical axis on the left of the graph represents the signal strength value where the axis on the right represents the magnetic strength value.

Any six frequencies can be plotted by typing the required frequency into the colour coded Frequency Legend. The numbers in grey to the right of each frequency show the instantaneous signal strengths at each frequency. Blank frequencies will not be plotted.

For clarity, the magnet strength chart example shown shows the EM detection has been deselected and the typical display of 1 cycle of magnet detection approaching and passing by the receiver and 1 stopped at the peak to display the legend value reads the signal in real time. When the signal is at its peak is when the magnetic detection is at its closest to the receiver.

The vertical scale can be adjusted by clicking and dragging the mouse up or down anywhere on the chart. If the chart has been clicked previously then you can also use the keyboard up and down arrows. Double clicking on the chart will autozoom to the visible data, this will automatically autozoom both the signal and mag graphs. The EM axis is displayed as a number value with a higher number being a stronger signal. The Mag axis is displaying the signal value in milli-Gauss.

The horizontal scale can be adjusted between 5 seconds and 60 seconds by clicking and dragging the mouse left or right anywhere on the chart.

The main window can be resized like a normal windows application. The individual chart heights can be adjusted by dragging the grey bar immediately below the intensity chart up or down.

5.8. WINDOWS SPECTRUM CHART

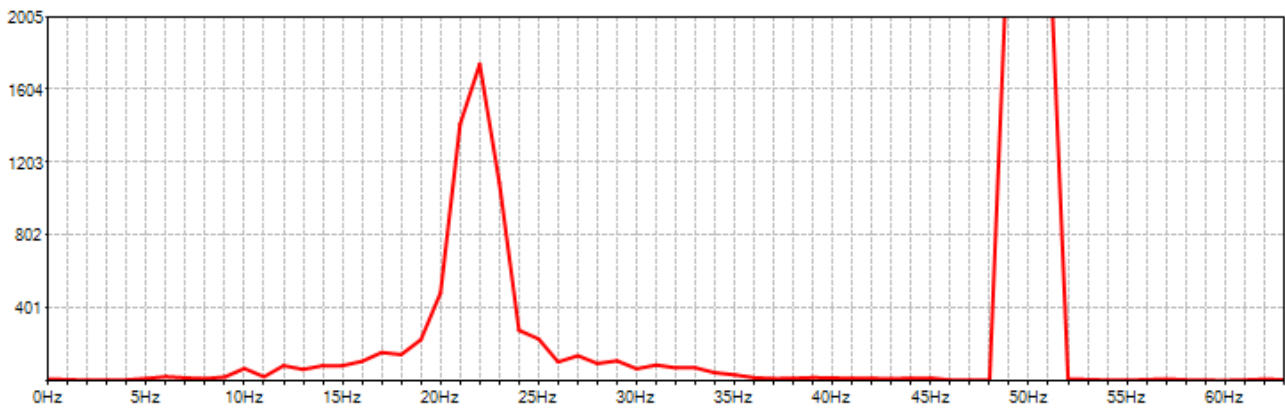

F The spectrum chart can be displayed in the lower half of the main window by pressing the relevant icon on the ribbon as per 5.5 WINDOWS RIBBON CONTROLS.

The spectrum analyser chart provides a live chart of signal against frequency. It is not usually required for normal EM transmitter reception but can be useful for debug purposes – particularly identifying significant noise sources outside the normal 10Hz to 30Hz range of interest.

The horizontal axis of the spectrum analyser is frequency (Hz) and the vertical axis is relative signal strength. The example shown above shows a strong signal component at 22Hz and a huge noise component at 50Hz. 50Hz and 60Hz are common noise frequencies due to their use for mains powered equipment and if large enough can compromise reception of signals in the normal 10Hz to 30Hz range and/or cause “clipping” of the input signal as per 5.11 WINDOWS EXCESSIVELY LARGE INPUT WARNING.

5.9. WINDOWS RAW CHART

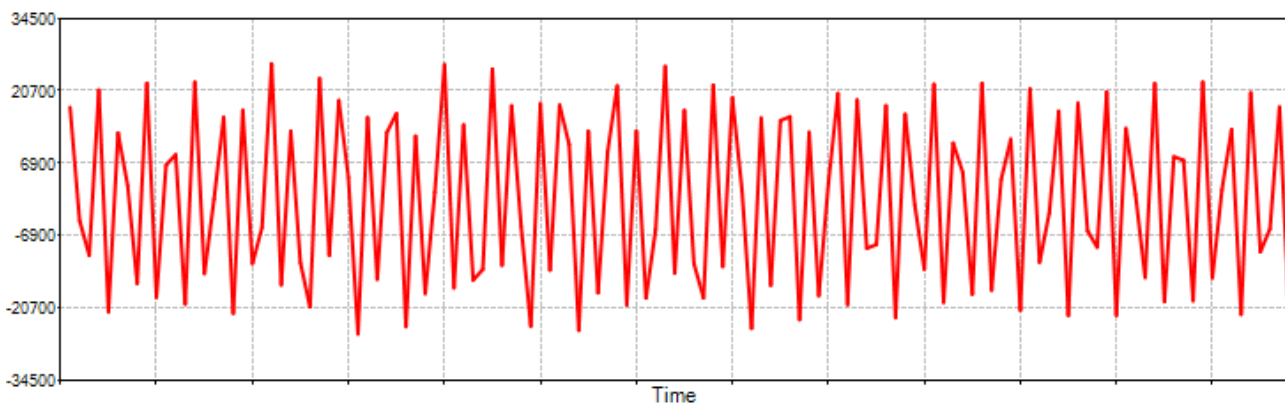

R The raw signal chart can be displayed in the lower half of the main window by pressing the relevant icon on the ribbon as per 5.5 WINDOWS RIBBON CONTROLS.

The raw signal chart provides a live chart of the raw signal being received by the EMRx prior to the digital signal processing. It is not usually required for normal EM transmitter reception but can be useful for debug purposes and particularly for identifying “clipping” of the input signal as per 5.11 WINDOWS EXCESSIVELY LARGE INPUT WARNING.

5.10. WINDOWS SETTINGS



The settings page can be displayed in the lower half of the main window by pressing the relevant icon on the ribbon as per 5.5 WINDOWS RIBBON CONTROLS.

5.10.1. CONNECTION CONFIGURE GROUP

The Connection Configure group is used to establish connection to an EMRx unit.

Select Device

Drop down list to allow selection of the required EMRx unit. EMRx units will appear in the list of available devices with name "EMRx Onshore ###" where "###" is the serial number of the EMRx unit. Note that all previously paired EMRx units will also appear in this list even if they are not powered or within range.

Connect

Disconnect

Connect/Disconnect to/from the device selected within the Select Device drop down list.

Bluetooth

Check to display only EMRx Bluetooth devices within the Select Device drop down list. Clicking on this item will refresh the list.

RS485

Check to display all available COM ports within the Select Device drop down list. Clicking on this item will refresh the list.

Demonstration

Check to simulate the signals from a 22Hz, 2 second pulse rate transmitter and a 17Hz, 5 seconds pulse rate transmitter being received simultaneously. This allows demonstration and training with the various controls and charts within the application without the need of an actual EMRx unit or EM transmitter.

Screenshot Folder

Data Folder

The screenshot and Data folder are where you can predetermine a folder in which to store the screenshots and where the logged files are automatically saved.

Load Data File

Load Data File is where you can import a previously saved files or files exported from an Android device.

5.10.2. HARDWARE CONFIGURE GROUP

The Hardware Configure group is used to view and modify settings on the EMRx unit. To refresh settings press the settings control within the 5.5 WINDOWS RIBBON CONTROLS.

The Write button is only required when updating the LED frequency settings, all other settings are sent to the connected EMRx unit as soon as they are modified. The EMRx unit will memorise settings even after it has been turned off.

When configuring the LED frequencies always ensure that a note is taken of the latest settings so that there is a record of what frequency each LED colour is assigned to otherwise the unit must be interrogated using the application or as per 3.2 TURNING ON to determine the current LED frequency settings.

Although the EMRx is only designed to work with frequencies between 10Hz and 30Hz the LED frequencies can be set to any frequency between 1Hz and 63Hz. To disable an LED bar graph set the corresponding LED frequency to 0Hz (zero).

Supply Voltage	Supply voltage (V) and percentage (%) of connected EMRx unit. A reading of 9.0V or more indicates new batteries are installed. A reading of 6.0V or below indicates critically low batteries are installed which should be replaced immediately.
Gain	Drop down list for gain setting of connected EMRx unit. See 3.3 GAIN ADJUSTMENT.
LED Frequency 1 (red)	Frequency settings for 3x available colour coded LED bar graphs of connected EMRx unit. Simply type in any frequency between 10Hz and 30Hz and then press the Write button.
LED Frequency 2 (blue)	
LED Frequency 3 (white)	
LED brightness	Drop down list for LED brightness setting of connected EMRx unit. Available settings are from 1 (lowest LED brightness) to 6 (highest LED brightness). Increasing LED brightness will reduce battery lifetime, so it is recommended that this setting is left at the default setting of 1 (minimum) whenever possible.
Filter <input checked="" type="checkbox"/>	This setting should be left ticked by default.
Low Noise <input checked="" type="checkbox"/>	This setting should be left ticked by default.
Light Switch <input type="checkbox"/>	If this setting is ticked, then the EMRx light switch control is enabled (if fitted).
Calibration <input type="text" value="200"/>	This setting is for information only.

5.10.3. SOFTWARE CONFIGURE GROUP

The Software Configure group is used to view and modify settings within the EMRx application.

N <input type="text" value="128"/>	This setting should be left at default 128.
Intensity Chart <input checked="" type="checkbox"/>	This setting enables or disables the Intensity Chart. Disabling the Intensity Chart may allow the application to run on lower performance devices.
Signal Chart <input checked="" type="checkbox"/>	This setting enables or disabled the Signal Chart. Disabling the Signal Chart may allow the application to run on lower performance devices.
Filter <input checked="" type="checkbox"/>	This setting should be left ticked by default.

Debug This setting should be left unticked by default.

Fresponse This setting should be left ticked by default.

Screenshot Folder This specifies the target folder for screenshots as per 5.12 SCREENSHOT. The default location is the host device Desktop. Press the Select button to specify an alternative location.

5.10.4. EMRX Magnetic

If the EMRX device has magnetic sensor, then the application will detect it and show additional interface elements.

The screenshot shows the 'Connection Configure' dialog box. At the top, there is a 'Load Data File' button and a 'Select Device' dropdown menu set to 'COM21 EMRx Onshore DEV'. To the right are 'Disconnect', 'Bluetooth' (selected), 'RS485', and 'Demonstration' radio buttons, along with an unchecked checkbox. Below this are three main configuration panels: 'Hardware Configure', 'Software Configure', and 'Firmware Configure'. The 'Hardware Configure' panel includes fields for 'Supply Voltage' (8.9, 96%), 'Gain' (1), 'LED Frequency 1 (red)' (22.0), 'LED Frequency 2 (blue)' (19.0), 'LED Frequency 3 (white)' (19.0), 'LED brightness' (1), 'Filter' (unchecked), 'Low Noise' (unchecked), 'Light Switch' (unchecked), 'Calibration' (128), and 'Magnetic Threshold' (65). At the bottom of this panel are 'MAG' and 'EM' buttons. The 'Software Configure' panel has a dropdown for 'N' (128) and checkboxes for 'Intensity Chart', 'Signal Chart', 'Filter', 'Debug', and 'Fresponse'. It also has 'Screenshot Folder' and 'Data Folder' text boxes, both set to 'C:\Users\Nari', with 'Select' buttons. The 'Firmware Configure' panel has 'Firmware Version' (EMRx10_3003_D00) and 'Bootloader Version' (EMRx10_3000_C00) text boxes, with 'Select Image' and 'Program' buttons. A status box shows 'No bootloader request detected' and a 'Cancel' button.

The additional elements allow the configuration of settings related to magnetic field measurements.



Sets the red LED to display magnetic field measurements.

NOTE: If the red LED is flashing when switched to magnetic mode then it is likely that either the magnetic threshold is too low, or there is a strong magnetic field in the vicinity.

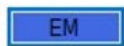

Sets the red LED to display electromagnetic field measurements.

Magnetic Threshold

Sets the magnetic threshold.

5.10.5. FIRMWARE CONFIGURE GROUP

DO NOT ATTEMPT TO UPDATE FIRMWARE WITHOUT THE EXPRESS PERMISSION OF IK TRAX.

The Firmware Configure group allows update of the firmware within an EMRx unit. To update the firmware, follow the steps below.

1. Ensure that the host device is not in "Flight Mode" and that Bluetooth is enabled. Both of these settings can be found in Start> Settings> Devices.
2. If not already done so, pair the EMRx unit with the host PC as per 5.3 WINDOWS BLUETOOTH PAIRING.
3. Open the EMRx application on the host device.
4. Turn the EMRx unit on.
5. Press and hold the EMRx control to turn the unit off but keep the control button depressed until told to release.
6. Confirm that the EMRx unit Bluetooth status LED starts flashing once every second indicating the Bluetooth interface is active and advertising for a connection.
7. Within the EMRx application Connection Configure group select the correct device from the "Select Device" drop down list. The EMRx unit will appear in the list of available devices with name "EMRx ###" where "###" is the serial number of the EMRx unit. Note that all previously paired EMRx units will also appear in this list even if they are not powered or within range.
8. Within the EMRx application Connection Configure group press the Connect button.
9. Confirm that the EMRx unit Bluetooth status LED starts flashing twice per second indicating that a connection has been established and then release the EMRx control.
10. If a successful connection is established the EMRx application will automatically show the Firmware Configure group with a Connected message and the Bootloader Version displayed. The EMRx Bluetooth status LED will be double flashing. If this is not the case, then restart at step 1.
11. Press Select Image and select the required *.txt firmware file.
12. Press Program and then wait until a Completed message is received. This can take several minutes. To prevent potential corruption of the firmware do not move or operate any controls on either the host PC or EMRx unit until the Completed message is received.
13. Turn the unit on and complete a quick function test as per 3.2 TURNING ON and 3.5 FUNCTION TEST. If the unit is not going to be used immediately then turn off as per 3.4 TURNING OFF.

5.11. WINDOWS EXCESSIVELY LARGE INPUT WARNING

If the gain setting is too high or an excessively large signal or noise is present, or the receiver is being moved excessively then the warning message below may be displayed and the EMRx unit will flash all LEDs to warn of "clipping" of the Raw Signal.

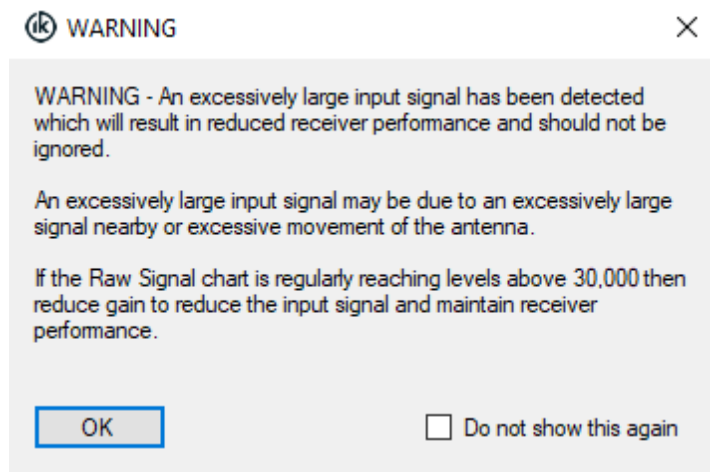

The image below shows an excessively large signal "clipping" the Raw Signal - notice the "clipped" peaks of the sine wave where they approach a reading of approximately 33,000. This excessively large signal may not be at a frequency that the user is aware of or expects. This clipping is distorting the signal which results in loss of valid frequency information and generation of spurious frequency information. THE EMRx RECEIVER MUST NEVER BE USED IF THIS IS HAPPENING.

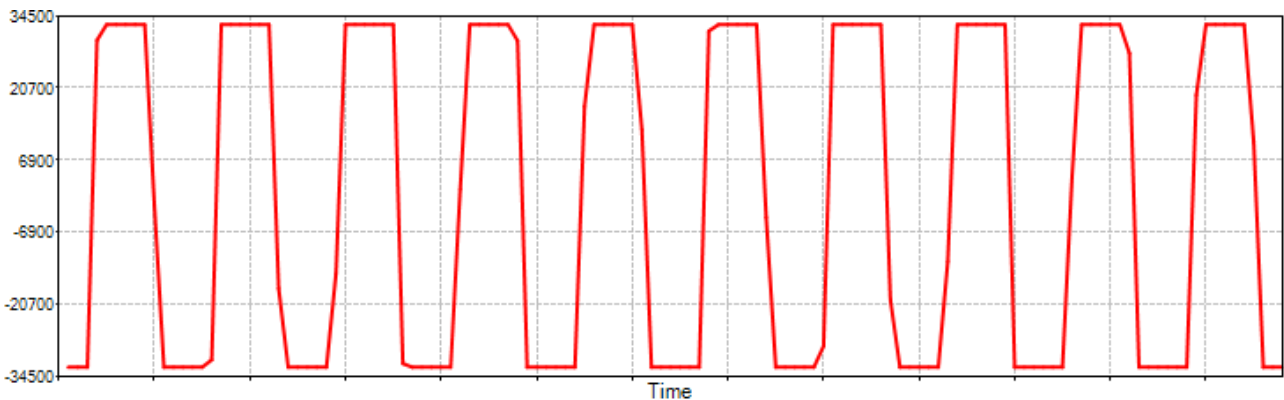

Gain must be reduced, or the receiver must be moved away from the source of the excessively large signal to reduce the signal to something which looks like the signal below - notice that the peaks of the sine wave are no longer "clipped" because they do not get anywhere near a reading of 33,000.

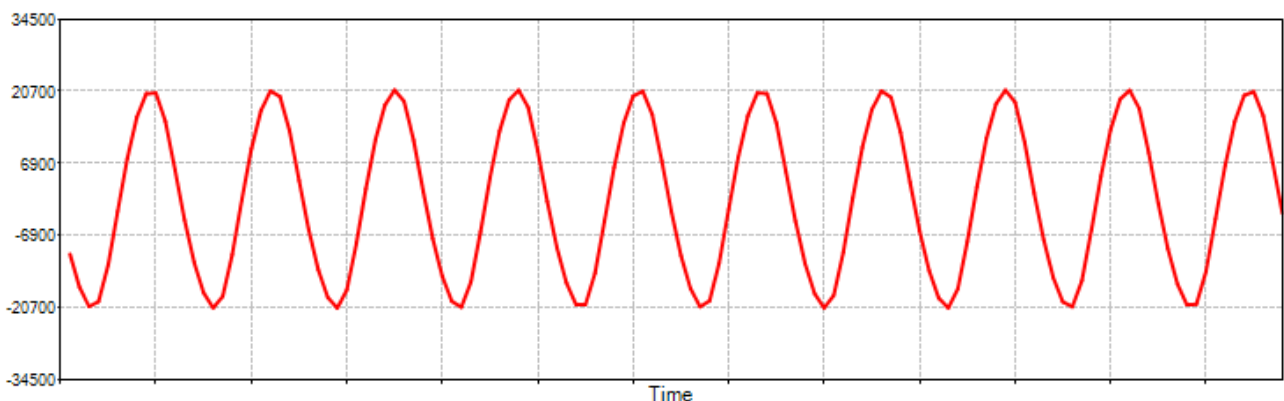

5.12. WINDOWS SCREENSHOT



At any point while using the application it is possible to capture a timestamped screenshot by pressing the screenshot icon on the ribbon as per 5.5 WINDOWS RIBBON CONTROLS.

Screenshots are saved in the specified screenshot folder as per 5.10.1 CONNECTION CONFIGURE GROUP.

Screenshots are saved as a *.png image with filename <COM## EMRx ### YYMMDD hhmss.png> where COM## is the COM port of the selected device, EMRx ### is the serial number of the selected device and YYMMDD hhmss is the screenshot date and time.

The title bar of the EMRx application includes COM port number, device serial number, date and time which will all appear on the screenshot itself.

For the screenshot feature to work reliably the desktop scale should be set to 100% on the host device (on a typical Windows 10 device this setting can be found under Start> Settings> System> Display> Scale and layout) and the application should be on the primary display.

5.13. DATA LOGGING

Data from the EMRx is automatically logged in the specified folder as per 5.10.1 CONNECTION CONFIGURE GROUP in 600 second segments. You can review previously logged data here and load data that has been exported from an Android device.

If the exported file is too large, when you click Load Data File on the Windows App it will pop up with a window as shown below. The number of files it breaks into depends on the size of the original file.

EMRx Ex 0002 231220 141045.bcn is too large. Only the last 600 seconds will be displayed.

Would you like to do the following?

- Back up the original file to a subfolder called 'Original Files'
- Split the original file into 4 files
- Display the first file on the charts

Yes

No

6. ROUTINE MAINTENANCE AND STORAGE

All IK Trax equipment is designed to require minimum maintenance. The housing should be cleaned using fresh water. Do not use chemicals, solvents or oils which could be damaging to the housing, endcaps or O-rings.

IK Trax can supply redress kits containing a complete set of replacement batteries, O-rings and O-ring grease, contact IK Trax for more information.

If the receiver is to be placed in storage for a long period of time remove the batteries from the receiver and store separately.

7. DISPOSAL OF UNIT

IK Trax former Online Electronics Ltd takes its responsibilities under the WEEE Regulations extremely seriously and has taken steps to be compliant in line with our corporate and social responsibilities. In the UK, IK Trax former Online Electronics Ltd has joined a registered compliance scheme WeeeCare (registration number WEE/MP3538PZ/SCH).

Electrical and electronic equipment should never be disposed of with general waste but must be separately collected for the proper treatment and recovery.

The crossed-out bin symbol, placed on the product, reminds you of the need to dispose of it correctly at the end of its life.

When buying a new product, you will have the possibility to return, free of charge, another end-of-life product of equivalent type that has fulfilled the same functions as the supplied equipment. These items may be deposited at:

IK Trax
Online House
Blackburn Business Park
Woodburn Road
Blackburn
Aberdeen
AB21 0PS
UK

Alternatively, to arrange a collection of any waste electrical equipment, obligated to IK Trax former Online Electronics Ltd please telephone WeeeCare on 0844 800 2004.

8. WARRANTY

IK Trax products are guaranteed for one year from the date of purchase. Goods should be returned, transportation prepaid IK Trax.

There is no charge for parts or labour, should any product require repair due to a manufacturing deficiency during the guarantee period.

In the event of a manufacturing deficiency the inward transportation costs will be repaid to the client.

9. CERTIFICATION APPENDIX

EQUIPMENT: EMRx Ex EM Receiver

MANUFACTURER: **IK Trax**
 Online House
 Blackburn Business Park
 Woodburn Road
 Blackburn
 Aberdeen
 AB21 0PS
 UK
 Tel: +44 (0) 1224 714 714
 Web: www.online-electronics.com

UKEx CERTIFICATE: EMA 22 UKEx 0049 X

ATEX CERTIFICATE: ERO 22 ATEX 0008 X

IECEX CERTIFICATE: IECEX EMT 22.0003 X

MARKINGS:  II 1 G Ex ia IIC T4 Ga

APPLICABLE STANDARDS: EN 60079-0:2018
 EN 60079-11:2012
 IEC60079-0:2017
 IEC60079-11:2011

SPECIAL CONDITIONS FOR SAFE USE:

1. WARNING – Do not open when an explosive atmosphere may be present.
2. WARNING – Use only one of the cell types from the table below. Do not install a mixture of cell types in the equipment.
3. WARNING – Allowable ambient temperature is dependent on the cell type used as per the table below.
4. WARNING – Observe correct battery polarity as indicated on the device.

	DURACELL MN1500	ENERGIZER E91	ENERGIZER L91
Allowable Ambient Temperature	-20°C to +54°C	-18°C to +55°C	-40°C to +60°C