



**TRAX**

**Intelligent Pipeline  
Technology**

## **ID5001P Operating Manual**

Non-Intrusive Acoustic Pig Signaller



**CONTENTS Page**

- 1. GENERAL DESCRIPTION ..... 3
- 2. SPECIFICATIONS ..... 4
- 3. RULES FOR SAFE OPERATION ..... 5
- 4. OPERATION ..... 6
  - 4.1. TURNING ON..... 6
  - 4.2. LISTENING ..... 7
  - 4.3. DETECTION ..... 7
  - 4.4. DETECTION ALGORITHM..... 8
  - 4.5. SINGLE BUTTON MENU INTERFACE..... 10
    - 4.5.1. MAIN MENU ..... 11
    - 4.5.2. EVENTS MENU..... 12
    - 4.5.3. SYSTEM INFO MENU..... 13
    - 4.5.4. LIVE DISPLAY MENU ..... 14
    - 4.5.5. OUTPUT CONFIG MENU ..... 15
    - 4.5.6. DETECT CONFIG MENU..... 16
  - 4.6. RS485 SERIAL INTERFACE..... 17
    - 4.6.1. MODBUS REGISTER MAP ..... 17
- 5. INSTALLATION ..... 19
  - 5.1. MAIN HOUSING MOUNTING PLATE..... 19
  - 5.2. MAIN HOUSING POST MOUNTING..... 19
  - 5.3. MAIN HOUSING PIPELINE MOUNTING ..... 20
  - 5.4. SENSOR MOUNTING ..... 20
  - 5.5. SUNSHADE POST MOUNTING ..... 21
  - 5.6. SUNSHADE PIPELINE MOUNTING..... 21
  - 5.7. OPENING THE HOUSING..... 22
  - 5.8. CLOSING THE HOUSING ..... 22
  - 5.9. BATTERY REMOVAL..... 23
  - 5.10. EXTERNAL CONNECTIONS ..... 24
    - 5.10.1. RELAY OUTPUT ..... 24
    - 5.10.2. EX CONNECTIONS ..... 25
    - 5.10.3. RS485 SERIAL INTERFACE ..... 25
    - 5.10.4. 0V CONNECTION ..... 25
    - 5.10.5. ENCLOSURE CONNECTION ..... 25
    - 5.10.6. REMOTE SWITCH CONNECTION ..... 25
    - 5.10.7. SWITCH CONNECTION ..... 25
    - 5.10.8. CURRENT LOOP OUTPUT..... 26
    - 5.10.9. VBAT CONNECTION..... 26
    - 5.10.10. EXTERNAL POWER CONNECTION ..... 26
- 6. ID5001P CONFIG APPLICATION ..... 27
  - 6.1. APPLICATION INSTALLATION ..... 28
  - 6.2. USING THE CONFIG APPLICATION ..... 29
    - 6.2.1. SETUP TAB ..... 29
    - 6.2.2. READ/WRITE TAB ..... 30
    - 6.2.3. READ ONLY TAB ..... 30
    - 6.2.4. BOOLEANS TAB ..... 31
    - 6.2.5. EVENTS TAB ..... 31
    - 6.2.6. LIVE VIEW WINDOW ..... 32
    - 6.2.7. EVENT VIEW WINDOW ..... 32
- 7. RECOMMENDED MAINTENANCE & STORAGE ..... 33
- 8. DISPOSAL OF UNIT ..... 34
- 9. WARRANTY ..... 34
- 10. CERTIFICATION APPENDIX ..... 35

<b>Revision</b>	<b>Updated By</b>	<b>Description of Update</b>	<b>Update Date</b>
D	BG	CR-24-01-04-01: Content now applicable to all battery types and company logo update.	31/01/24
	AGO	CR-24-09-23-01: Update application screenshot with new logo and fix minor errors in section 6.	02/10/24

# 1. GENERAL DESCRIPTION

The ID5001P (Passive) pig signaller is a fully ATEX, UKEX and IECEx certified, Exd flameproof, non-intrusive, pig signaller which detects, signals, and logs the passage of pigs at critical points along a pipeline both on land and offshore.

The unit uses Passive (listening) techniques to detect pig passage events. Events are signalled as they occur via a 3" graphical LCD display and high brightness LEDs positioned above and below the display. Events can also be signalled remotely using several optional outputs.

The unit logs the time and date of up to 99 events which can be viewed at any point using the local display. The user can turn the unit ON and OFF as well as modify several settings using a single control button and intuitive menu system.

The unit has two basic parts as shown below. The sensor is permanently connected to the main housing via a cable and can be quickly and easily attached to the pipeline using ratchet straps or steel banding. The main housing contains all electronics, batteries (if fitted), display and the control button and can be mounted onto the pipeline using a mounting plate and straps in a similar fashion to the sensor or mounted on a wall or post.

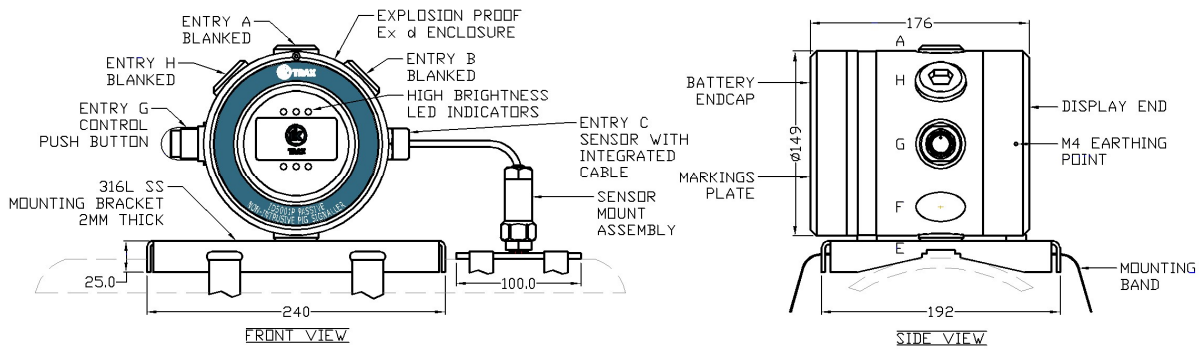

## 2. SPECIFICATIONS

### GENERAL

External Supply .....	24.0VDC, <2.0W
Battery type .....	7x Alkaline DURACELL ID1300 cells
Battery life (Alkaline) in LISTENING/LOW POWER MODE at +20°C.....	15 days
Battery type .....	7x Lithium SAFT LS33600 cells
Battery life (Lithium) in LISTENING/LOW POWER MODE at +20°C .....	30 days
Housing Ambient Temperature range (External supply) .....	-40°C to +85°C (-40°F to +185°F)
Housing Ambient Temperature range (Alkaline).....	-20°C to +54°C (-40°F to +130°F)
Housing Ambient Temperature range (Lithium) .....	-40°C to +85°C (-40°F to +185°F)
Sensor Ambient Temperature Range .....	-55°C to +110°C
Maximum Allowable Pipeline Surface Temperature .....	+150°C <sup>NOTE1</sup>
Typical minimum pig speed.....	0.1m/s <sup>NOTE2</sup>
Main Housing Ingress Protection.....	IP66
Sensor Ingress Protection.....	IP68
ATEX/UKEX/IECEX code.....	 II 1/2 G Ex ia/db [ia Ga] IIC T4..T6 Ga/Gb
EU Type Examination Certificate Number .....	TRAC 13 ATEX 0008X
UKEX Certificate Number .....	EMA22UKEX0006X
IECEX Certificate Number .....	IECEX TRC 13.0006X
Weight in Aluminium.....	8kg
Weight in Stainless Steel .....	13kg

### OUTPUTS

DPDT Relay Output (Volt Free Contacts).....	2A @ 30VDC <sup>NOTE3</sup>
Current Loop Output .....	4-20mA <sup>NOTE4</sup>
Serial Data Interface.....	RS485 MODBUS

<sup>NOTE1</sup> Maximum allowable pipeline surface temperature depends on ambient air temperature and mounting configuration. Only the sensor may be mounted on the pipeline.

<sup>NOTE2</sup> Minimum pig speed depends on pig type, pipeline configuration and installation position.

<sup>NOTE3</sup> DPDT is equivalent to 2x SPDT.

<sup>NOTE4</sup> Current Loop levels are configurable between 4mA and 20mA. Default set state 20.0mA. Default reset state 4.0mA. Tolerance ±1.0mA.

### 3. RULES FOR SAFE OPERATION

**⚠ WARNING:** The Special Conditions for Safe Use as detailed in section 10 CERTIFICATION APPENDIX must be followed.

**⚠ WARNING:** The purchaser of this equipment is responsible for the training and competence of operators and the way in which it is used. This manual should be read through and understood before installation and commissioning so that the operator is familiar with the equipment. Contact IK Trax immediately should any difficulty arise in the use of this equipment.

**⚠ CAUTION:** If the equipment is to be placed in storage, always ensure that it is turned OFF and the batteries (if fitted) are removed and stored separately.

## 4. OPERATION

Familiarise yourself with all of the rules for the safe operation of this equipment as described in section 3 RULES FOR SAFE OPERATION.

### 4.1. TURNING ON

If powered from 24.0VDC power supply via the VEXT connection the unit will turn on automatically as soon as power is applied. If powered from batteries simply press and hold the control button until the COMPANY LOGO appears on the display and then release, this takes approximately 5 seconds.

The COMPANY LOGO will be displayed for 5 seconds as shown by the COUNTDOWN INDICATOR located at the top left-hand side of the display.

When the COUNTDOWN INDICATOR reaches zero or the CONTROL BUTTON is pressed, the next screen will appear.

The next screen shows the PRODUCT LOGO and firmware version at the bottom of the screen.

The next screen shows the current system date and time. If the date and time are blank as shown then the date and time will require setting via the menu system or RS485 MODBUS serial interface.

The unit now enters STABILISATION. During STABILISATION the unit will initialise the detection filters and acquire the ambient noise level of the pipeline.

Once STABILISATION is complete the unit will enter LISTENING mode. In LISTENING mode, the display will be switched off and the LEDs will flash every 5 seconds to indicate that the unit is active. See section 4.2 LISTENING for more information.

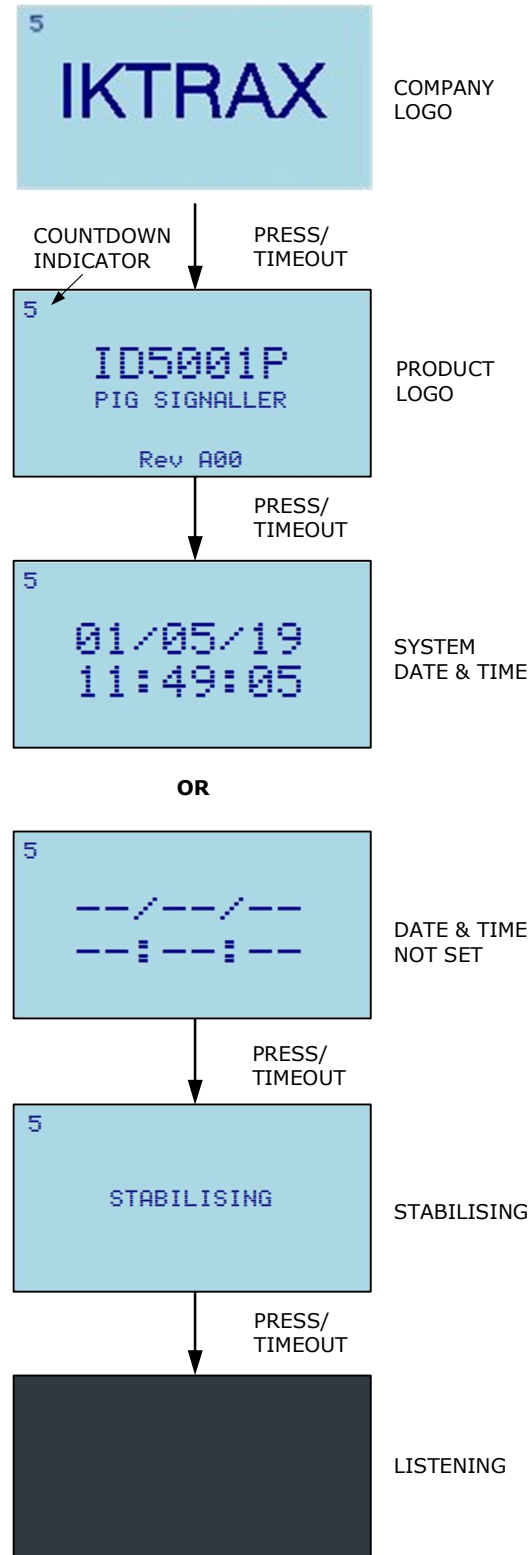

## 4.2. LISTENING

While in LISTENING mode the unit continuously monitors the acoustic energy produced by the pipeline as it waits for a pig passage to occur. The unit is configured to recognize the unique sound signature produced by a pig as it passes the sensor. The unit uses the algorithm described in section 4.4 DETECTION ALGORITHM to detect a pig passage.

While in LISTENING mode the display will be off and the LEDs above and below the display will flash every five seconds to indicate that the unit is active. The relay and current loop outputs will be in LISTENING state.

There are two things that may cause the display to change:

**CONTROL BUTTON** – If the control button is pressed the unit will enter the MENU system. The menu system is described in section 4.5 SINGLE BUTTON MENU INTERFACE.

**PIG APPROACH** – If the unit detects a possible pig approaching the sensor then the display will show a PIG APPROACH message as shown. From this point the unit will continue running through the detection algorithm until either the approach is cancelled, in which case the display shall turn off, or it will signal pig detected as per section 4.3 DETECTION.



## 4.3. DETECTION

When a pig is detected the display will show a PIG DETECTED message including the time and date of the event as shown. The LEDs above and below the display will flash every second and the relay and current loop will be in the DETECTION state. The time and date of the pig passage are stored in internal memory and can be viewed later using the menu interface.



The unit will remain in the DETECTION state for the length of time defined by the OUTPUT DELAY before returning to LISTENING mode. The OUTPUT DELAY can be bypassed by pressing the CONTROL BUTTON.

**OUTPUT DELAY** – The OUTPUT DELAY controls how long the unit will signal an event for. Usually it will be configured to give the pig enough time to get out of range of the sensor after it has been detected to avoid re-trigger. When dealing with pig trains, the expected pig speed and separation should be used to configure a suitable value for the OUTPUT DELAY such that the unit will not detect the same pig twice but will enter LISTENING mode in time to detect the next pig.

**LATCHED DETECTION** – If the OUTPUT DELAY HH (hours) field is set to 99 then when an EVENT occurs the unit will LATCH in DETECTION mode showing the EVENT information and flashing the LEDs every 1 second. To begin LISTENING again the CONTROL BUTTON must be pressed or the detection reset using the serial interface.

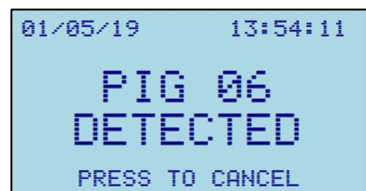



#### 4.4. DETECTION ALGORITHM

Below is a simplified flowchart for the ID5001P detection algorithm which is running while the unit is in LISTENING mode.

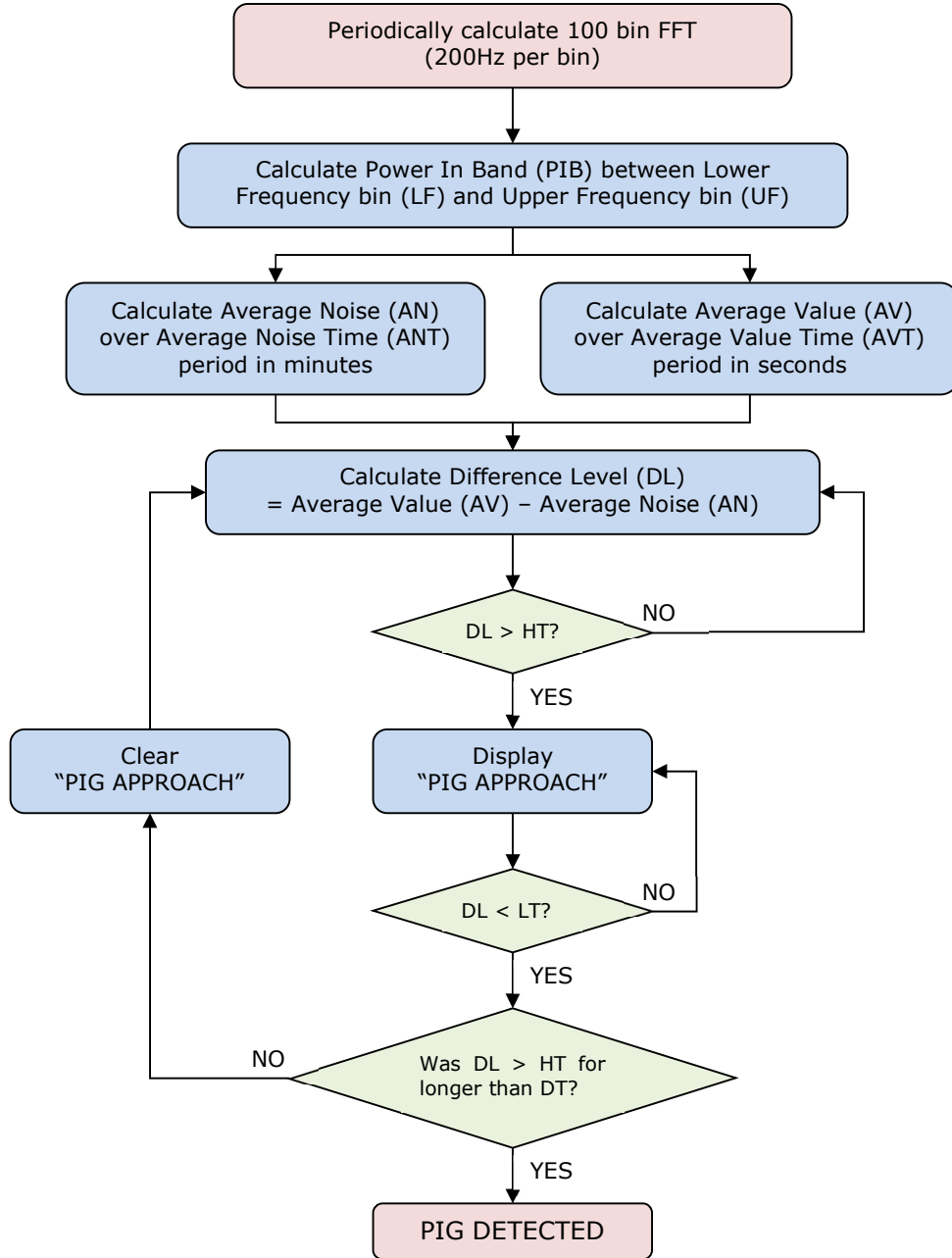

Below is a graphical representation a typical pig passage.

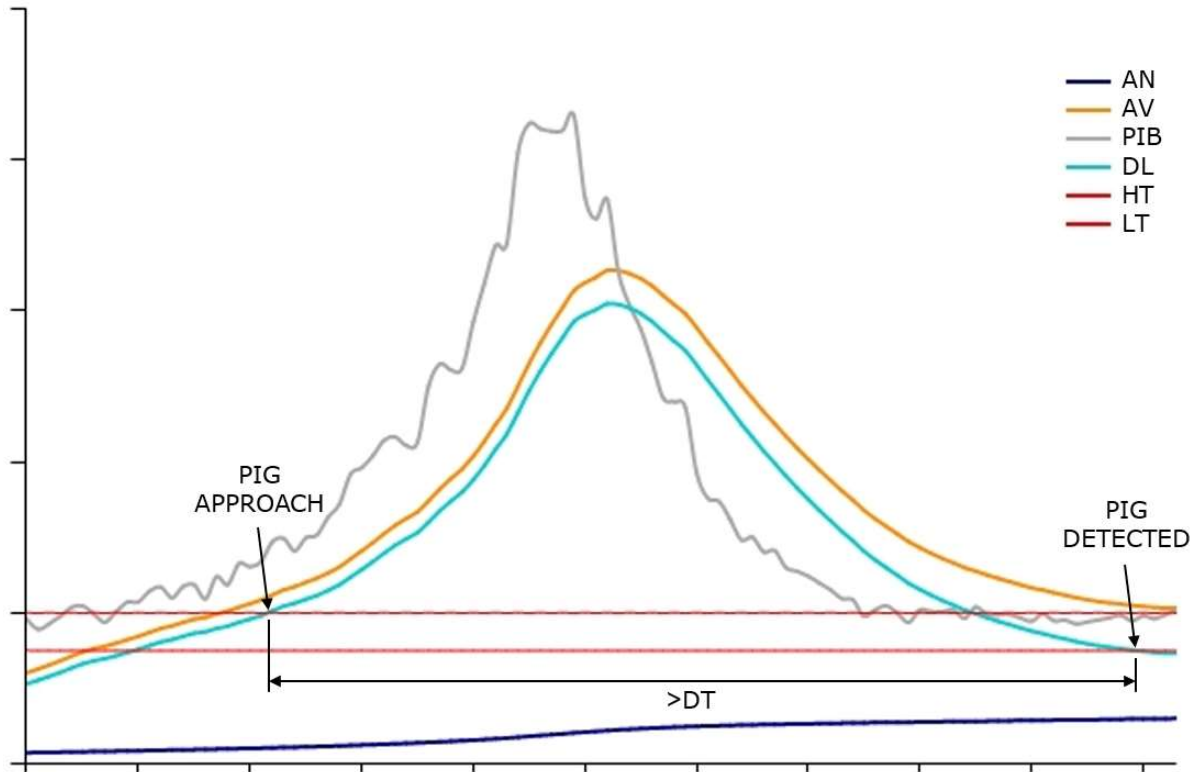

PIB	= Power In Band	(between Lower Frequency bin (LF) and Upper Frequency bin (UF))
AN	= Average Noise	(PIB averaged over Average Noise Time (ANT) period in minutes)
AV	= Average Value	(PIB averaged over Average Value Time (AVT) period in seconds)
DL	= Difference Level	(Average Value (AV) - Average Noise (AN))
HT	= High Threshold	(user set High Threshold)
LT	= Low Threshold	(user set Low Threshold)
DT	= Delta Time	(time DL is above HT before returning below LT must exceed DT seconds otherwise the approach will be cleared)

## 4.5. SINGLE BUTTON MENU INTERFACE

While LISTENING, the control button can be pressed to enter the menu interface. From the menu system the user can configure several parameters which are discussed in this section.

When any menu screen is loaded the cursor will initially be located at the home position at the top right corner next to the page number to indicate that the BACK action will occur when the countdown expires.

Pressing the control button causes the CURSOR to move down to the next menu item and the COUNTDOWN INDICATOR will be reset to 5. Once the CURSOR is pointing at the desired item the user simply allows the COUNTDOWN INDICATOR to reach 0 and the selected item will be executed. This simple behaviour is used throughout the menu interface to modify settings and interact with the unit.

If the active menu has multiple pages, as indicated in the top right-hand corner then when the last item is reached the next button press will load the next page and the cursor will return to the home position. When the end of the last page is reached then the unit will loop back to page 1 of the active menu.

If the selected item is a menu then when the countdown expires the new menu is loaded, otherwise if the item is an editable field then the display will go into edit mode to allow the value to be changed. In edit mode the part of the field actively being edited is enclosed in a box to highlight it. Some parameters will provide additional information on screen while editing such as min and max values. All parameters are incremented by pressing the CONTROL BUTTON until they are at the desired value. Allowing the COUNTDOWN INDICATOR to reach 0 either selects the next editable digit in the field if there is one, otherwise edit mode will exit and the new value will be saved.

If while editing a parameter value you wish to cancel the edit operation, then press and hold the CONTROL BUTTON until the cursor returns to the home position.

If an item was selected accidentally then simply press and hold the CONTROL BUTTON until the cursor returns to the home position or allow the COUNTDOWN INDICATOR to reach 0 without pressing the CONTROL BUTTON.

The menu system is designed so that the unit will always return to LISTENING mode if the CONTROL BUTTON is left released for a long enough time.

Below is the typical layout of a menu screen:

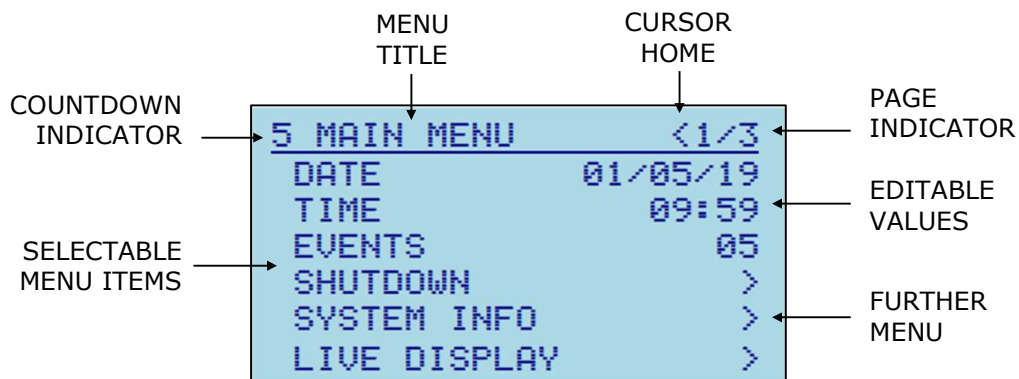

### 4.5.1. MAIN MENU

The MAIN MENU is the initial entry point to the menu system. This menu consists of three pages as shown.

**DATE** – Select this item to edit the system date. Ensure that a valid date is entered in DD/MM/YY format.

**TIME** – Select this item to edit the system time. Ensure that a valid time is entered in 24hour HH:MM format. Seconds will be set to 0 when the time edit completes.

**EVENTS** – Indicates the number of stored events. Select this item to view or delete events via the EVENTS menu. See section 4.5.2 EVENTS MENU.

**SHUTDOWN** – Select this item to switch off the unit. The unit has memory backup and will remember all settings until next time the unit is switched on. It is imperative that the unit is turned off using this command rather than simply disconnecting the external power supply to allow any memory storage processes to complete prior to turning OFF. Once turned off the unit can be turned back on either by pressing the CONTROL BUTTON for 5 seconds or by cycling the external power supply.

**SYSTEM INFO** – Select this item to access the System Info menu. See section 4.5.3 SYSTEM INFO MENU.

**LIVE DISPLAY** – Select this item to access the Live Display menu. See section 4.5.4 LIVE DISPLAY MENU.

**LOW POWER MODE** – Select this item to turn Low Power Mode ON or OFF. Low power mode only has an influence when the unit is being powered from the internal battery pack. If low power mode is ON, then while the pipeline is quiet the sensor will sample at a reduced frequency and the RS485 MODBUS interface will be disabled to preserve battery life.

**OUTPUT CONFIG** – Select this item to configure the output functionality of the unit. See section 4.5.5 OUTPUT CONFIG MENU.

**DETECT CONFIG** – Select this item to configure the detection parameters used by the unit to detect pig passages. See section 4.5.6 DETECT CONFIG MENU.

**MODBUS ADDRESS** – Select this item to edit the RS485 MODBUS slave address (1 – 247).

**LANGUAGE** – Select this item to change the system language.

**FORMAT SD CARD** – Select this item to format the internal SD card (if fitted).

The following LCD parameters will require the user to press the CONTROL BUTTON within 5 seconds, to save after editing the value. This feature is to try and prevent the display becoming unreadable. If after editing a value the display is unreadable then just let the countdown timeout and the previous value will be reloaded.

**LCD CONTRAST** – Select this item to edit the LCD contrast (65 – 99%).

**LCD BL FREQ** – Select this item to edit the LCD backlight frequency (100 – 200Hz).

**LCD BL DUTY** – Select this item to edit the LCD backlight duty cycle (1 – 99%).

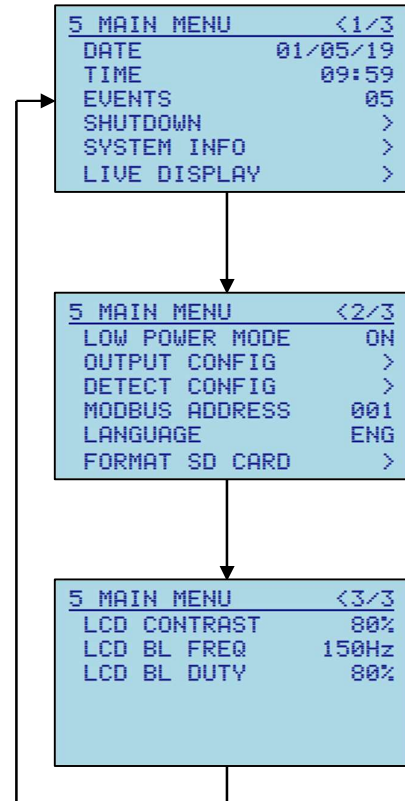

#### 4.5.2. EVENTS MENU

The EVENTS MENU allows the user to view and erase the EVENTS stored in the unit memory.

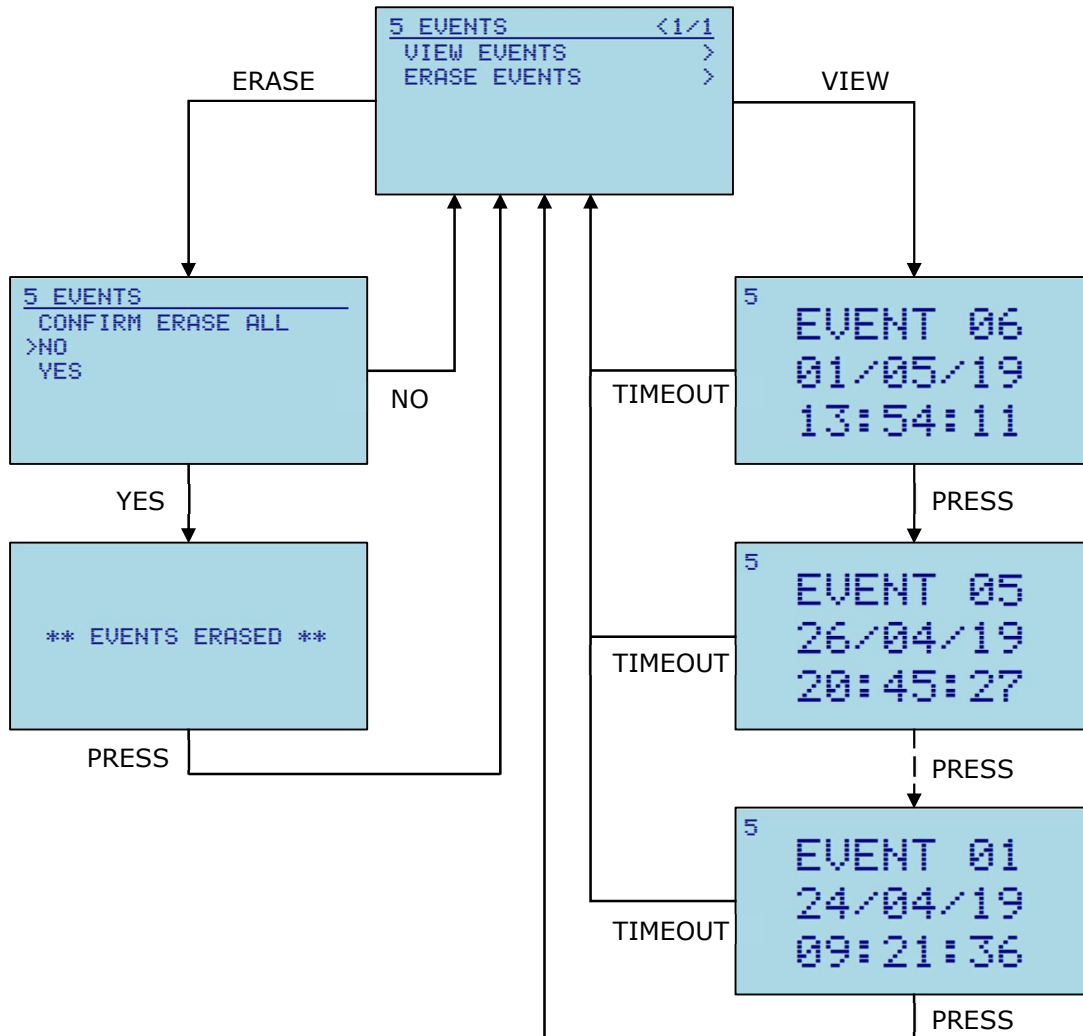

**VIEW EVENTS** – Selecting this item will allow the user to cycle through all logged EVENTS from newest to oldest. The EVENT number, date and time are shown. Pressing the CONTROL BUTTON will cycle to the next event. The CONTROL BUTTON can be held to pause at any event. If the COUNTDOWN INDICATOR reaches 0 then the unit will return to the EVENTS MENU.

**ERASE EVENTS** – Selecting this item will ERASE all logged EVENT data. The user will be prompted to confirm this action before proceeding with the ERASE as this action cannot be undone. To cancel the ERASE simply ensure NO is selected before the countdown expires. If YES is selected, then a message will appear to indicate that the EVENTS have been erased before returning to the EVENTS MENU.

### 4.5.3. SYSTEM INFO MENU

The SYSTEM INFO MENU is largely read only and is primarily used to display certain system parameters to the user.

5 SYSTEM INFO	<1/1
SERIAL NO	12345
FIRMWARE	Rev A00
BAT TYPE	LS33600
BAT VOLTAGE	24.5V
POWER SUPPLY	VEXT

**SERIAL NO** – READ ONLY – The unit serial number is configured at time of manufacture.

**FIRMWARE** – This item shows the currently installed firmware version. Select this item to upgrade the unit firmware via USB. This action will require confirmation from the user before proceeding as the unit will be locked up in the bootloader until either a new firmware image is uploaded, or the unit power is cycled. This procedure should only be undertaken by OEL staff or following instruction from OEL.

**BAT TYPE** – READ ONLY – This item indicates the type of batteries that the unit is configured to work with. This is configured at the time of manufacture.

**BAT VOLTAGE** – READ ONLY – This item indicates the voltage of the battery pack if fitted otherwise "NO BAT" will be displayed.

**POWER SUPPLY** – READ ONLY – This item indicates whether the unit is currently being powered from an external power supply (VEXT) or from the internal batteries (VBAT) if fitted.

#### 4.5.4. LIVE DISPLAY MENU

The LIVE DISPLAY MENU gives the user access to the three available diagnostic screens. These screens allow the user to view the live signals being monitored by the unit which is useful to confirm correct operation and when making changes to the detection parameters.

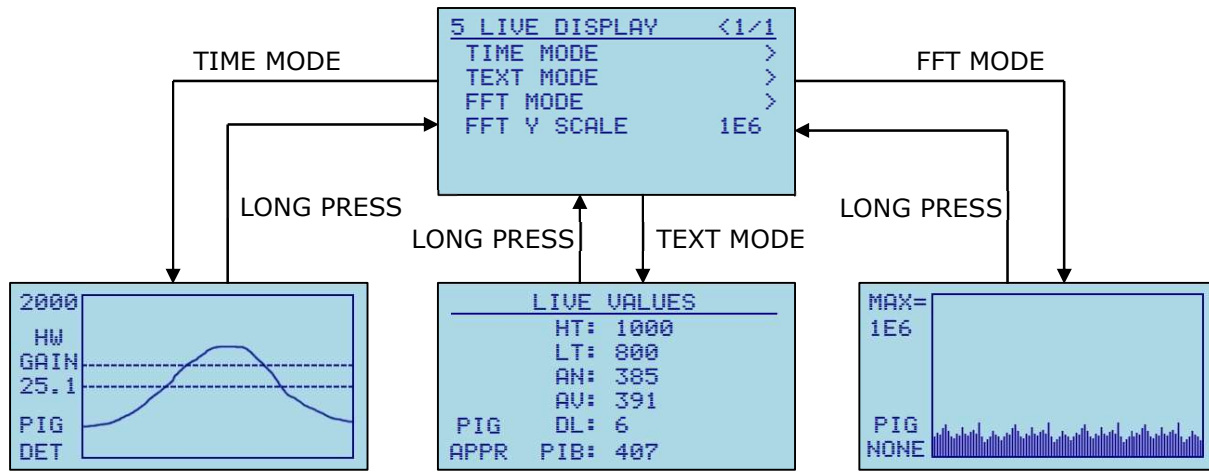

**TIME MODE** – This mode displays a live graphical plot of the Difference Level (DL) vs time. The High Threshold (HT) and the Low Threshold (LT) are indicated by the dashed lines. The Y axis is auto scaling based on the maximum value of Difference Level (DL).

**TEXT MODE** – This mode shows the following live values in text form: High Threshold (HT), Low Threshold (LT), Average Noise (AN), Average Value (AV), Difference Level (DL) and Power In Band (PIB).

**FFT MODE** – This mode displays a live graphical plot of the full FFT bandwidth (0 – 20kHz). There are 100 points along the X axis, each representing a 200Hz FFT bin result.

**FFT Y SCALE** – Selecting this item allows the user to edit the Y scale for the FFT plot. The Y scale can be set to either AUTO or to one of the predefined maximum values. Due to the limited space on the display the available maximum values are defined in the following way: 1E4 =  $1 \times 10^4 = 10000$ , 2E4 =  $2 \times 10^4 = 20000$  etc.

When viewing a live screen, the pig passage status shall be indicated in the lower left corner by either of the following messages: "PIG NONE" (Listening), "PIG APPR" (Pig Approaching) or "PIG DET" (Pig Detected).

Pressing the CONTROL BUTTON while the unit is in APPROACH or DETECT mode will return the unit to LISTENING mode. A LONG BUTTON PRESS is required to exit the live display screen and return to the menu system.

#### 4.5.5. OUTPUT CONFIG MENU

The OUTPUT CONFIG MENU allows the user to configure the output functionality of the unit. This menu consists of two pages as shown.

**OUTPUT DELAY** – Select this item to modify the OUTPUT DELAY in HH:MM:SS format. The OUTPUT DELAY dictates how long the unit will indicate DETECTION before returning to LISTENING mode. This can take any value from 00:00:00 up to 98:59:59.

**CL OUTPUT** – Select this item to enable or disable the CURRENT LOOP output functionality. If the CURRENT LOOP output is disabled the loop current will be 2mA, otherwise, the loop current will be either the user defined LISTENING or DETECTION level.

**CL LISTEN** – Select this item to edit the CURRENT LOOP LISTENING level (4.0 – 20.0mA).

**CL DETECT** – Select this item to edit the CURRENT LOOP DETECTION level (4.0 – 20.0mA).

**CL IF** – This item should not be changed by the user. This will be configured at the time of manufacture to interface with the ID5000IF unit if required.

**RELAY INVERT** – Select this item to enable or disable the inverse operation of the relay.

**LED FLASH** – Select this item to enable or disable the flashing high brightness LEDs fitted above and below the LCD display.

**VAL SD LOG** – Select this item to enable or disable logging of the raw data to the internal SD card (if fitted). It is imperative that the unit is shutdown correctly using the menu system before removing the SD card otherwise the log file will not be terminated correctly and all recorded data may be permanently lost.

**FFT SD LOG** – Select this item to enable or disable logging of the FFT data to the internal SD card (if fitted). It is imperative that the unit is shutdown correctly using the menu system before removing the SD card otherwise the log file will not be terminated correctly and all recorded data may be permanently lost.

**RESET TO DEFAULTS** – Selecting this item will reset all output parameters to their default values. This option requires the user to confirm before it is actioned.

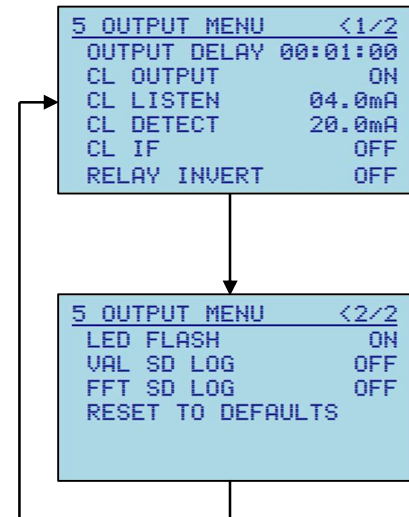



#### 4.5.6. DETECT CONFIG MENU

**ADJUSTING THESE PARAMETERS WITHOUT FIRST CONSULTING IK Trax MAY CAUSE THE UNIT TO MISS PIG PASSAGES OR GIVE FALSE DETECTIONS.**

The DETECT CONFIG MENU allows the user to configure the detection parameters for the unit. This menu consists of three pages as shown.

**HIGH THRESHOLD** – The Difference Level (DL) must exceed this threshold before the unit will consider a possible pig approach. (0 – 65535)

**LOW THRESHOLD** – The Difference Level (DL) must fall below this threshold after being above High Threshold (HT) to trigger a pig detection. (0 – 65535)

**DELTA TIME** – The length of time the Difference Level (DL) must be above the Low Threshold (LT) after exceeding the High Threshold (HT) before the unit will indicate a detection. If the time does not exceed this value, then the pig approach will be cancelled. (1 – 100 seconds)

**AV VALUE TIME** – The time period the Power In-Band (PIB) is averaged over to calculate the Average Value (AV). (1 – 100 seconds)

**AV NOISE TIME** – The time period the Power In-Band (PIB) is averaged over to calculate the Average Noise (AN). (1 – 100 minutes)

**AV NOISE OVER** – The value of Average Noise (AN) can be overridden by the user, if this value is set to zero then the calculated Average Noise (AN) will be used. (0 – 65535)

**NUM AVERAGES** – The number of samples that will be averaged to calculate the Power In-Band (PIB). Increasing this value will smooth the resultant PIB output waveform at the expense of increased processing time to compute the FFTs. (1 – 50)

**UPPER FREQ BIN** – The highest frequency bin to be included in the Power In-Band (PIB). 200Hz/bin (1 – 100)

**LOWER FREQ BIN** – The lowest frequency bin to be included in the Power In-Band (PIB). 200Hz/bin (1 – 100)

**HARDWARE GAIN** – The hardware gain configuration. (1 – 4)

**SENSOR GAIN** – The sensor gain level. (1 – 12000)

**HP FILTER** – Enables or disables the hardware high pass filter stage.

**RESET TO DEFAULTS** – Selecting this item will reset all detection parameters to their default values. This option requires the user to confirm before it is actioned.

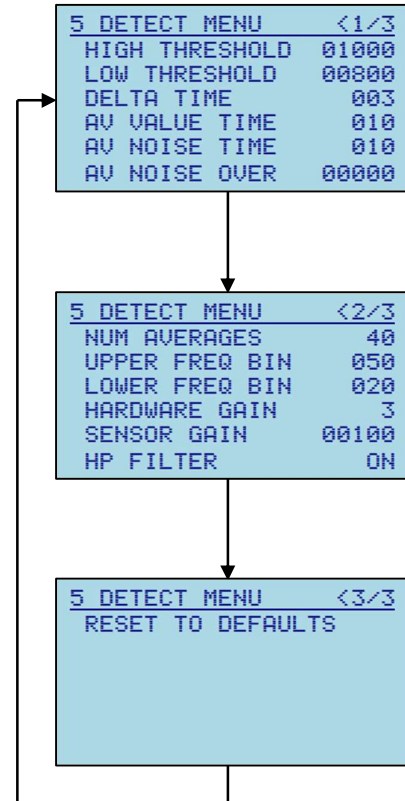

## 4.6. RS485 SERIAL INTERFACE

Communication to the ID5001P, via the RS485 interface, makes use of MODBUS RTU protocol. All the parameters available in the ID5001P menu system can also be accessed via the MODBUS interface. The serial interface should be configured as follows:

9600 baud, 8 data bits, 1 stop bit, no parity

**⚠ WARNING:** Care should be taken when remotely controlling/configuring the unit via the MODBUS interface as values set intentionally, or unintentionally, will immediately affect the operation of the ID5001P. E.g. enabling relay inversion, although a useful test, will cause the relay to switch and signal an event when no event is active.

If the ID5001P is powered from batteries, and LOW POWER MODE is enabled, then the RS485 interface will be disabled. If you require to use the RS485 interface while powered from batteries then LOW power mode must be disabled, although be aware that this will significantly reduce the battery lifetime.

### 4.6.1. MODBUS REGISTER MAP

COILS		
0	Log Values to SD card	Write 1 to enable or 0 to disable
1	Log FFT to SD card	Write 1 to enable or 0 to disable
2	Invert Relay Operation	Write 1 to enable or 0 to disable
3	Current Loop Enable	Write 1 to enable or 0 to disable
4	Current Loop IF Enable	Write 1 to enable or 0 to disable
5	High Pass Filter Enable	Write 1 to enable or 0 to disable
6	LED Flash Enable	Write 1 to enable or 0 to disable
7	Low Power Mode Enable	Write 1 to enable or 0 to disable
15	Pig Detected	Read Only – Pig detection status
16	Reset Detect Parameters	Write 1 to reset detect parameters
17	Reset Output Parameters	Write 1 to reset output parameters
18	Erase Events	Write 1 to erase the stored events

INPUT REGISTERS		
0	Average Noise (AN) High	Upper word (bits 31:16)
1	Average Noise (AN) Low	Lower word (bits 15:0)
2	Average Value (AV) High	Upper word (bits 31:16)
3	Average Value (AV) Low	Lower word (bits 15:0)
4	Difference Level (DL) High	Upper word (bits 31:16)
5	Difference Level (DL) Low	Lower word (bits 15:0)
6	Power In-Band (PIB) High	Upper word (bits 31:16)
7	Power In-Band (PIB) Low	Lower word (bits 15:0)
8	Number of Events	0 - 99
14	Firmware Type	5001
15	Firmware Revision	Major Rev ASCII (bits 15:8) Minor Rev (bits 7:0)
16	Event Year	Selected event date
17	Event Month	Selected event date
18	Event Day	Selected event date
19	Event Hour	Selected event time
20	Event Minutes	Selected event time
21	Event Seconds	Selected event time
22	CPU Temperature	°C
23	Battery Voltage	mV
25	Unit Serial No	0 - 65535

HOLDING REGISTERS		
0	Upper Freq Bin (UF)	0 - 100 (200Hz/bin)
1	Lower Freq Bin (LF)	0 - 100 (200Hz/bin)
2	Number of Averages (NA)	1 - 50
3	Average Noise Time (ANT)	1 - 100 minutes
4	Average Value Time (AVT)	1 - 100 seconds
5	Hardware Gain (HG)	1 - 4
6	Delta Time (DT)	1 - 100 seconds
7	Output Delay Hours	0 - 99 hours
8	Output Delay Minutes	0 - 59 minutes
9	Output Delay Seconds	0 - 59 seconds
10	High Threshold (HT)	0 - 65535
11	Low Threshold (LT)	0 - 65535
12	Sensor Gain (SG)	1 - 12000
13	Average Noise Override (ANO)	0 - 65535
14	Current Loop Listening Level	Val = $(I_{mA} \times 65536)/24$
15	Current Loop Detected Level	Val = $(I_{mA} \times 65536)/24$
16	LCD Contrast	65 - 99
17	LCD Backlight	Freq = Val/100, Duty = Val%100
18	MODBUS Slave Address	1 - 247
19	Language	0 = ENG, 1 = FRA, 2 = ESP
32	System Year	System date
33	System Month	System date
34	System Day	System date
35	System Hour	System time
36	System Minute	System time
37	System Second	System time
38	Selected Event Number	0 - 99, Input registers selected event number

## 5. INSTALLATION

**⚠ WARNING:** The instructions detailed within the product certificate and the Special Conditions for Safe Use as detailed in section 10 CERTIFICATION APPENDIX of this manual must be followed at all times.

Normally the unit is used to confirm whether or not a pig has passed a known point of interest on a pipeline such as a bend or valve. The unit should be mounted approximately 5m after the point of interest and a test run completed to confirm successful installation and reliable detection.

If the main housing is exposed to direct sunshine, then it is recommended that a sunshade is installed to prevent unnecessary heating of the unit which may shorten the lifespan of the equipment. See sections 5.5 SUNSHADE POST MOUNTING and 5.6 SUNSHADE PIPELINE MOUNTING.

### 5.1. MAIN HOUSING MOUNTING PLATE

The unit is supplied with a mounting plate as shown which is suitable for use with ratchet straps or steel banding and for mounting the unit onto pipelines, posts and walls.

If the unit is post mounted, then 4x M8x120 coach bolts should be fitted as per 5.2 MAIN HOUSING POST MOUNTING prior to attaching the mounting plate.

The mounting plate is attached to the main housing as shown using 2x M8x16 bolts / 2x M8 spring washers / 2x M8 plain washers / mounting plate / 2x M8x5 spacers / main electronics housing.

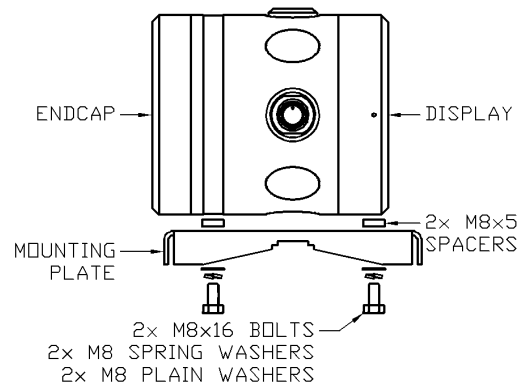

### 5.2. MAIN HOUSING POST MOUNTING

The post mounted unit is supplied with a post mounting assembly as shown.

1. Prior to fitting the mounting plate as per 5.1 MAIN HOUSING MOUNTING PLATE pass the 4x M8x120 coach bolts through the mounting plate.
2. Hold the assembly in position on the post and secure using 4x M8 nuts / 4x M8 washers / post mount clamp / post / mounting plate / 4x M8x120 coach bolts as shown (view from above).
3. If equipotential bonding, or earthing is required, then the M4 threads around the perimeter of the display endcap may be used.

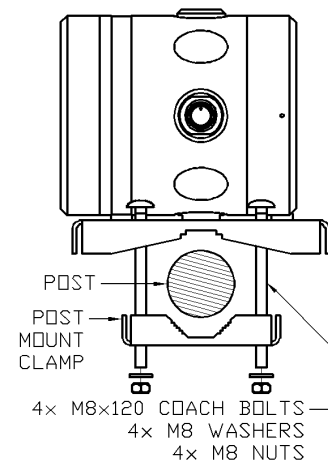

### 5.3. MAIN HOUSING PIPELINE MOUNTING

The pipeline mounted unit is supplied with a set of ratchet straps or steel banding as shown.

1. If the pipeline surface temperature is expected to exceed the maximum permitted ambient temperature for the enclosure as per the tables in the Special Conditions for Safe Use within section 10 CERTIFICATION APPENDIX then the housing must NOT be fitted on the pipeline.
2. Ensure the mounting plate is securely fitted to the housing as per 5.1 MAIN HOUSING MOUNTING PLATE.
3. Temporarily place the unit at the chosen location to ensure that the unit sits in place without rocking excessively.
4. Thread 2x loops of banding through the slots provided in the mounting plate as shown and then following the instructions provided with the banding gradually tighten the banding until the unit is held firmly. Do not use excessive force.
5. If equipotential bonding, or earthing is required, then the M4 threads around the perimeter of the display endcap may be used.

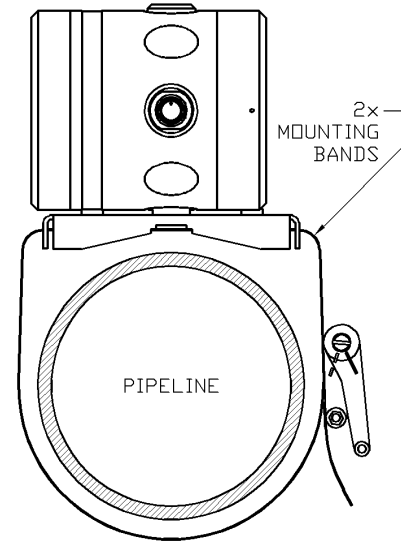

### 5.4. SENSOR MOUNTING

For optimum results, ensure that the pipeline surface at the point of installation is uniform, clean and smooth. If the surface is irregular, corroded, or has flaking paint, then an abrasive paper or wire brush should be used to prepare the surface. The unit will operate effectively through most painted layers as long as they are clean, uniform and are fully bonded to the pipeline surface, however in the case of surface coatings which contain air gaps, foam coatings, concrete coatings, thermally insulating coatings or composite coatings consisting of several materials with different densities, an area of coating should be removed to allow installation of the sensor directly onto the bare pipeline surface.

The sensor is supplied with a mounting plate, a mounting stud, a PEEK insulator (if required) and a length of mounting band.

1. If the pipeline surface temperature is expected to exceed  $+85^{\circ}\text{C}$  then the sensor must be fitted on the lower half of the pipeline as shown to minimise convection heating and a PEEK insulator must be fitted to thermally insulate the sensor from the pipeline. IK Trax should be contacted for further guidance. Do NOT exceed 3Nm tightening torque if using the PEEK insulator or the threads may be damaged.
2. Pass the mounting stud or insulator (if required) through the  $\varnothing 6\text{mm}$  hole in the mounting band and then screw into the mounting plate approximately 4 full turns. Do not tighten further at this point.
3. Loop the mounting band around the pipeline and then following the instructions provided with the banding gradually tighten the banding until the mounting assembly is held firmly. Do not use excessive force.

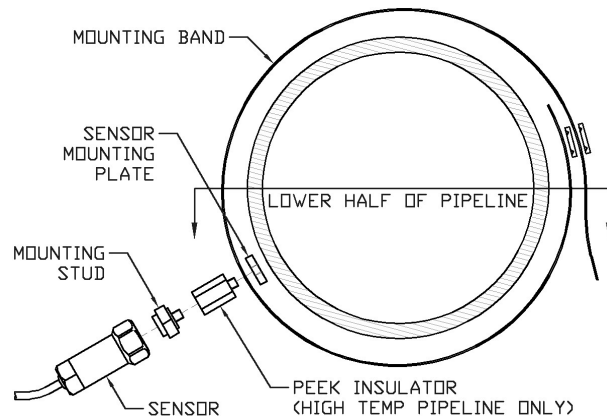

4. Ensure that the mounting plate is positioned to form a cross with the mounting band and the mounting band has been firmly tightened before fully tightening the mounting stud into the mounting plate using a 21mm AF wrench or the insulator (if required) using a 15mm AF wrench. DO NOT exceed 3Nm tightening torque if using the PEEK insulator or the threads may be damaged. It should not be possible to move the mounting plate at this point.
5. Attach the ID5001P sensor to the mounting stud, tightening using a 1" AF wrench. DO NOT exceed 3Nm tightening torque if using the PEEK insulator or the threads may be damaged.

## 5.5. SUNSHADE POST MOUNTING

If the main housing is exposed to direct sunshine, then it is recommended that a sunshade is installed to prevent unnecessary heating of the unit which may shorten the lifespan of the equipment.

Secure the post mount sunshade to the post as shown using the supplied M8 U-bolt / post / clamp / sunshade / 2x M8 washers / 2x M8 nuts.

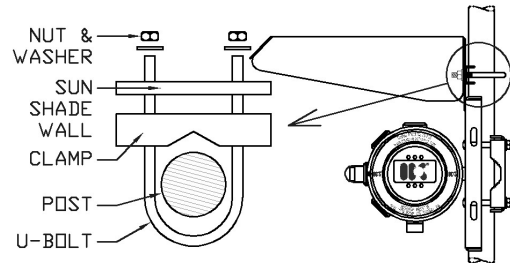

## 5.6. SUNSHADE PIPELINE MOUNTING

If the main housing is exposed to direct sunshine, then it is recommended that a sunshade is installed to prevent unnecessary heating of the unit which may shorten the lifespan of the equipment.

The pipeline mounted sunshade is fixed to the same mounting plate as the main unit using 2x 'C' brackets as shown. This assembly is then mounted onto the pipeline as described in section 5.3 MAIN HOUSING PIPELINE MOUNTING.

Secure 2x pipeline mount sunshade brackets to the mounting plate using 4x M8x20 hexbolts / 2x 'C' brackets / mounting plate / 4x M8 nuts.

Secure the sunshade to the 2x brackets using 4x M8x20 hexbolts / 4x M8 washers / sunshade / 2x 'C' brackets / 4x M8 nuts.

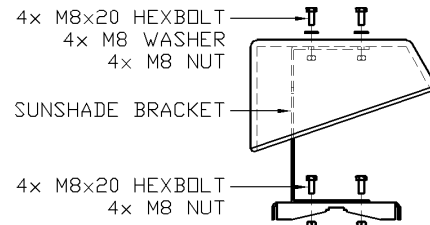

## 5.7. OPENING THE HOUSING

**⚠ WARNING:** The instructions detailed within the product certificate and the Special Conditions for Safe Use as detailed in section 10 CERTIFICATION APPENDIX of this manual must be followed at all times.

1. **⚠ WARNING – DO NOT OPEN WHEN ENERGIZED.**
2. Using a 3mm AF Allen key loosen the M4 locking screw located at the 12 o'clock position on the REAR ENDCAP 6x full turns.
3. Carefully unscrew the rear endcap REAR ENDCAP while being prepared to take the weight when it disengages. There are 4x unthreaded holes around the perimeter of the endcap which may be used should leverage be required.

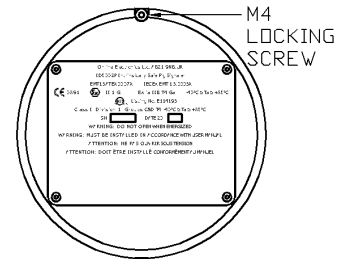

## 5.8. CLOSING THE HOUSING

1. Gently hand tighten the REAR ENDCAP. Do not use tools or over tighten otherwise the endcap will be difficult to remove. The M4 locking screw should be at the 12 o'clock position when the endcap is fully engaged, there should still be a small gap (<0.5mm) between the endcap and housing.
2. Using a 3mm AF Allen key gently tighten the M4 locking screw located at the 12 o'clock position on the REAR ENDCAP. Do not over tighten, very little torque is required to lock the endcap in place.

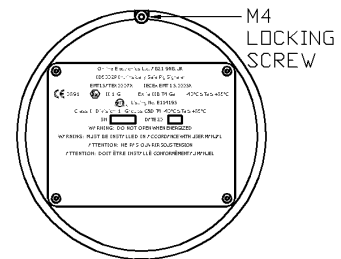

## 5.9. BATTERY REMOVAL

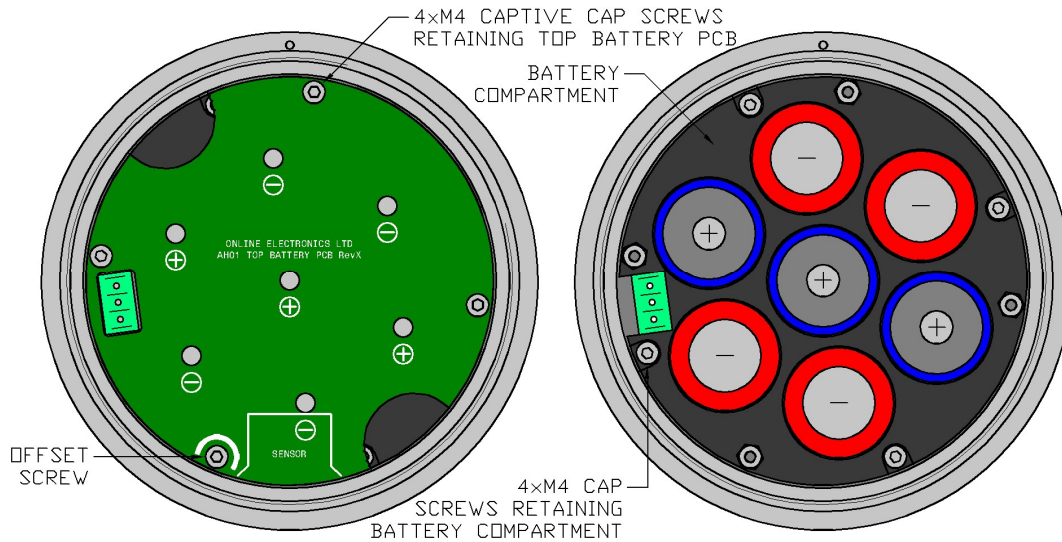

If the unit has been requested to be either battery powered or external supply with battery back-up, the unit will have been configured at the time of manufacture with either DURACELL INDUSTRIAL ID1300 alkaline **OR** SAFT LS33600 lithium cells. Depending on this configuration the unit will shut down when the battery voltage reaches 6.5V for alkaline or 17.0V for lithium. To replace the batteries, follow the steps below:

1. The Special Conditions for Safe Use, detailed in section 10 CERTIFICATION APPENDIX of this manual must always be observed. Only the cell type stated on the marking plate affixed to the unit should be installed.
2. Using a 3mm AF Allen key loosen the M4 locking screw located at the 12 o'clock position on the REAR ENDCAP 6x full turns.
3. Carefully unscrew the REAR ENDCAP while being prepared to take the weight when it disengages. There are 4x unthreaded holes around the perimeter of the endcap which may be used should leverage be required.
4. The TOP BATTERY PCB should now be visible as shown above. Using a 3mm AF Allen key loosen all 4x captive cap screws 3x full turns each before fully disengaging all screws and removing the TOP BATTERY PCB.
5. Replace all batteries confirming that their polarity matches the information shown on the TOP BATTERY PCB. The negative end of each battery should be in contact with a spring.

**REPLACE ALL BATTERIES AT THE SAME TIME. NEVER USE A MIX OF NEW AND USED BATTERIES. NEVER USE A MIX OF BATTERIES FROM DIFFERENT BATCHES. ENSURE THAT THE CORRECT BATTERY TYPE IS USED. ALWAYS OBSERVE CORRECT BATTERY POLARITY.**

6. Replace the TOP BATTERY PCB checking that the orientation is correct. Note that one of the retaining screws is offset to prevent incorrect orientation.
7. Replace the REAR ENDCAP and gently hand tighten. Do not use tools or over tighten otherwise the endcap will be difficult to remove. The M4 locking screw should be located close to the 12 o'clock position when the endcap is fully engaged, there should still be a small gap (<0.5mm) between the endcap and housing.
8. Using a 3mm AF Allen key gently tighten the M4 locking screw. Do not over tighten, very little torque is required to lock the endcap in place.



## 5.10. EXTERNAL CONNECTIONS

To access external connections, follow the steps below:

1. The Special Conditions for Safe Use detailed in section 10 CERTIFICATION APPENDIX of this manual must be observed at all times.
2. Remove the REAR ENDCAP as described in section 5.9 BATTERY REMOVAL of this manual.
3. Remove the BATTERY COMPARTMENT (if fitted) by first removing the TOP BATTERY PCB, and batteries as described in section 5.9 BATTERY REMOVAL of this manual. Then using a 3mm AF Allen key, remove the 4xM4 cap screws which hold the BATTERY COMPARTMENT in place and remove the BATTERY COMPARTMENT to reveal the external connections as shown.

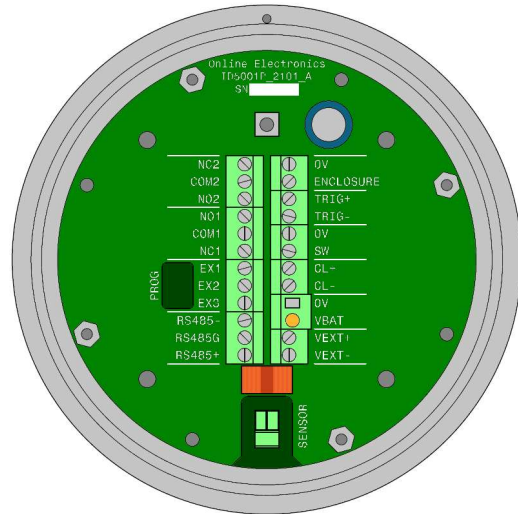

All connections are made using 5.08mm pitch removable terminal blocks which can accept up to 2.5mm<sup>2</sup> (14AWG) wire size. All connections must be made using suitable crimp ferrules. Connections are clearly labelled on the PCB and have the following functions:

NC1/NC2	- Normally closed contact of relay pole 1 and 2
COM1/COM2	- Common contact of relay pole 1 and 2
NO1/NO2	- Normally Open contact of relay pole 1 and 2
EX1,EX2,EX3	- Do NOT use
RS485-	- RS485 DATA INVERTING
RS485G	- RS485 GND
RS485+	- RS485 DATA NON-INVERTING
0V	- 0V reference for the PCBs
ENCLOSURE	- Electrical connection to the enclosure
TRIG±	- Do NOT use
SW	- Switch connection (CONTROL BUTTON)
CL±	- Current loop supply
VBAT	- Do NOT use
VEXT±	- External 24VDC supply

Note that a spring pin may be fitted at VBAT to make the connection to the BATTERY COMPARTMENT (if fitted). Care must be taken to avoid damage or obstruction of this contact. When replacing the BATTERY COMPARTMENT ensure that it is aligned correctly so that this connection is made properly.

### 5.10.1. RELAY OUTPUT

The relay output is DPDT (Double Pole Double Throw) meaning that there are two separate sets of contacts (NC1 / COM1 / NO1 and NC2 / COM2 / NO2). These may be connected to two separate external circuits. Contact rating is 30VDC @ 2A.

While in the LISTENING state, the Normally Closed contacts of the relays will be connected to their respective Common contacts and the Normally Open contacts will be open.

While in the DETECTION state, the Normally Closed contacts of the relays will be open, and the Normally Open contacts will be connected to their respective Common contacts.

The default relay states can be reversed by setting the RELAY INVERT to ON using the menu system. The same thing can be achieved by simply swapping wiring between the NO and NC connections.

### **5.10.2. EX CONNECTIONS**

EX1, EX2 and EX3 are reserved for future use.

Do NOT use these connections.

### **5.10.3. RS485 SERIAL INTERFACE**

RS485+ / RS485- / RS485G provide an RS485 interface for remote signalling and interaction with the unit.

RS485+ / RS485- / RS485G are isolated from 0V and all other connections.

### **5.10.4. 0V CONNECTION**

0V is the 0V reference for the internal PCBs. 0V should be linked to the ENCLOSURE connection to improve electrical noise immunity.

### **5.10.5. ENCLOSURE CONNECTION**

ENCLOSURE provides an electrical connection to the main enclosure. ENCLOSURE should be linked to the 0V connection to improve electrical noise immunity.

ENCLOSURE is isolated from 0V (unless a link is fitted between 0V and ENCLOSURE).

If equipotential bonding, or earthing is required, then there are 2x M4 threads around the perimeter of the display endcap. As per e.g. EN60079-14:2008 section 12.2.4 the ID5001P must be isolated from earth or connected at one point to the equipotential bonding system.

### **5.10.6. REMOTE SWITCH CONNECTION**

Do NOT use the TRIG+ / TRIG- connections.

TRIG+ / TRIG- are isolated from 0V and all other connections.

### **5.10.7. SWITCH CONNECTION**

The local CONTROL BUTTON is connected between SW and 0V.

### **5.10.8. CURRENT LOOP OUTPUT**

CL+ / CL- provide a current loop output for remote signalling.

CL+ is connected to the current loop supply (in to unit).  
CL- is connected to the current loop return (out of unit).

CL+ / CL- are isolated from 0V and all other connections.

When the unit is switched on and the CL function is disabled the CL output will consume 2.0mA.

When the unit is switched on and the CL function is enabled then the CL output will consume either the LISTENING or DETECTION level current depending on the state of the signaller.

While in the LISTENING state, the CL output will consume the user configurable LISTENING current (4.0mA default).

While in the DETECTION state, the CL output will consume the user configurable DETECTION current (20.0mA default).

### **5.10.9. VBAT CONNECTION**

This connection is for the internal BATTERY COMPARTMENT (if fitted).

Do NOT use this connection.

### **5.10.10. EXTERNAL POWER CONNECTION**

The external 24VDC power supply should be connected to the VEXT+ / VEXT- connections.

VEXT+ / VEXT- are isolated from 0V and all other connections.

## 6. ID5001P CONFIG APPLICATION

The ID5001P Config application is used to monitor and configure ID5001P Pig Signallers over the RS485 serial interface.

The application allows the user access to the following items remotely from a computer:

- Set system date and time
- Configure all system, output and detection parameters
- Monitor PIG detection status
- Monitor live sensor values
- View and download PIG event data from the unit memory

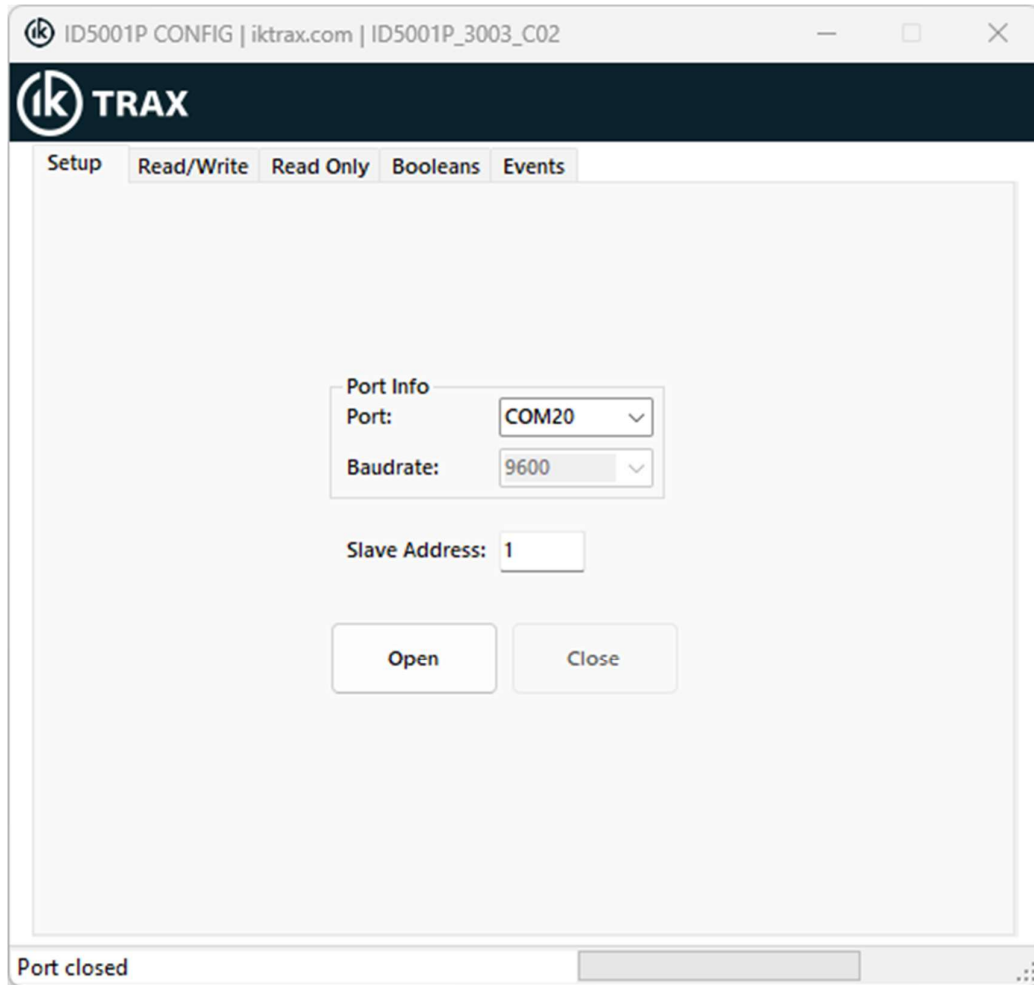

## **6.1. APPLICATION INSTALLATION**

Ensure that the application has been installed and tested in advance of when it will actually be required.

The application requires the Microsoft .NET Framework to be installed on the host PC. Depending on which operating system is running on the host PC it may be necessary to upgrade to the latest version of the .NET framework by visiting <https://dotnet.microsoft.com/download>.

The installation folder for the application has typical name ID5001P\_3003\_C02 ID5001P CONFIG WINDOWS INSTALL which represents the full application name and version.

The typical size of the installation folder is 1MB.

Simply unzip the folder if applicable, save the folder into any location on the target device, run the setup.exe file found within the folder and then follow the instructions when prompted. A shortcut to the application will be automatically added to the Start menu and desktop.

## 6.2. USING THE CONFIG APPLICATION

**⚠ WARNING:** Care should be taken when remotely controlling/configuring the unit as values set intentionally, or unintentionally, will immediately affect the operation of the ID5001P. E.g. enabling relay inversion, although a useful test, will cause the relay to switch and signal an event when no event is active. It is recommended that the user familiarise themselves with the operation of the ID5001P and the config application in a test environment before using it to configure a unit in the field.

The config application opens in a window that contains multiple tabs that can be selected to view the different types of information available. The function of each tab is described in the following sections.

### 6.2.1. SETUP TAB

When the application launches the initial tab will be the Setup tab.

Ensure the USB to RS485 cable has been plugged into the computer and any driver installation has completed.

**PORT** - Select the appropriate COM Port from the drop down list then click OPEN to open the port. If the port has opened successfully a message will be displayed in the status bar located in the bottom left corner of the application window.

**BAUD RATE** - Currently 9600 is the only supported baud rate.

**SLAVE ADDRESS** - If there are multiple devices on the RS485 bus then each will require to have a unique slave address configured to allow communications to function correctly. The default slave address configured for all devices at time of manufacture is 1. This text box allows the user to select which slave device the application will be communicating with. Address 0 has a special broadcast function which can be used to write data to all devices simultaneously, this could be useful for synchronising date and time for example. Only write operations can use broadcast, read operations are not possible as it is impossible to receive a response from all slave devices simultaneously.

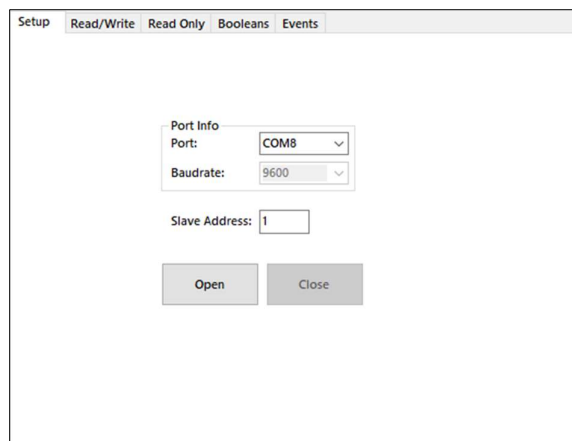

The screenshot shows a software window titled 'Setup' with several tabs: 'Setup', 'Read/Write', 'Read Only', 'Booleans', and 'Events'. The 'Setup' tab is selected. Inside the window, there is a 'Port Info' section. It includes a 'Port:' dropdown menu currently showing 'COM8', and a 'Baudrate:' dropdown menu currently showing '9600'. Below these is a 'Slave Address:' text input field containing the number '1'. At the bottom of the window are two buttons: 'Open' and 'Close'.

### 6.2.2. READ/WRITE TAB

The Read/Write tab is used to configure all the numerical parameters that can be both read from and written to.

For a full description of each parameter refer to sections 4.5.5 OUTPUT CONFIG MENU and 4.5.6 DETECT CONFIG MENU

**READ** – Pressing the READ button will read all Read/Write parameter values from the unit.

**WRITE** – In order to write a new value to the unit select the checkbox next to the value you wish to edit, amend the value in the Value cell then press the WRITE SELECTED button. If the write is successful a message will be displayed in the status bar located in the bottom left corner of the application window.

**SYNC DATE & TIME** – Pressing the SYNC TO PC TIME button will send the current PC date and time to the unit.

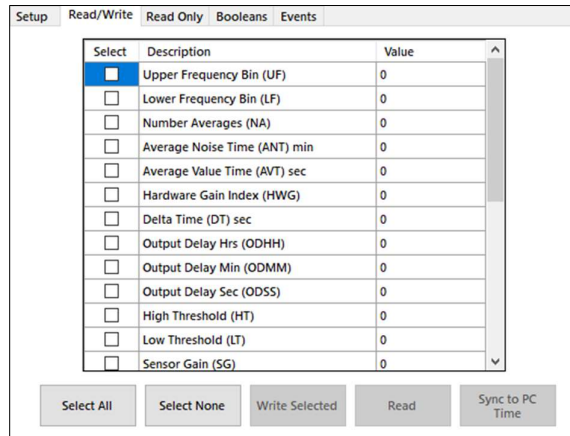

### 6.2.3. READ ONLY TAB

The Read Only tab displays all the read only parameters which include the pig detection status, live sensor values and various system parameters.

**READ** – Pressing the READ button will read all the Read Only parameter values from the unit.

**POLL** – Pressing the POLL button will read all the read only values continuously at rate of 2Hz.

**PLOT** – Pressing the PLOT button will open a new window that will show a graphical plot of the live sensor values on the screen. For a full description of the functionality of the Live Data View window refer to section 6.2.6 LIVE DATA VIEW WINDOW.

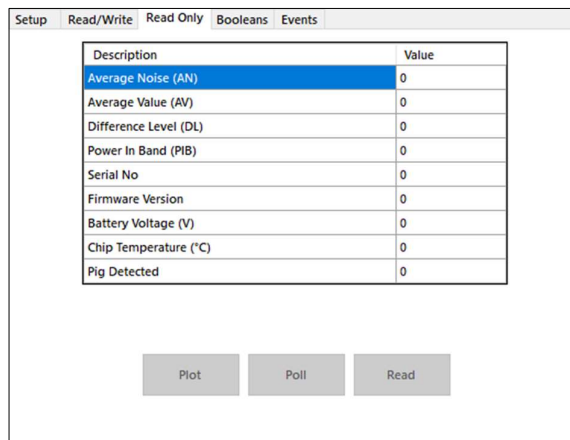

### 6.2.4. BOOLEANS TAB

The Booleans tab is used to configure all the boolean parameters that can be both read from and written to.

For a full description of each parameter refer to sections 4.5.5 OUTPUT CONFIG MENU and 4.5.6 DETECT CONFIG MENU

**READ** – Pressing the READ button will read all boolean parameter values from the unit.

**WRITE** – In order to write a new value to the unit select the checkbox to the left of the value you wish to edit, amend the value in the On cell by either checking or unchecking the box then press the WRITE SELECTED button. If the write is successful a message will be displayed in the status bar located in the bottom left corner of the application window.

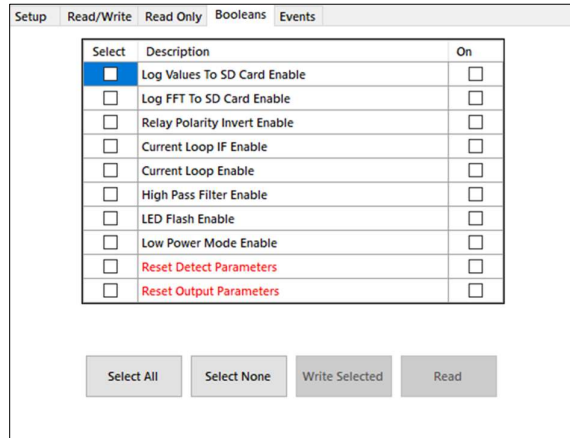

### 6.2.5. EVENTS TAB

The Events tab is used to view and download PIG event data from the unit.

For each PIG event the unit stores a header containing a date & time stamp and setting configuration together with 104 sets of sensor readings prior to the event trigger point.

**READ** – Pressing the READ button will read all logged PIG event headers and display all the date & time stamps in the list box. If there are a large number of events recorded it may take a few seconds to read all the event header data from the unit and populate the list box.

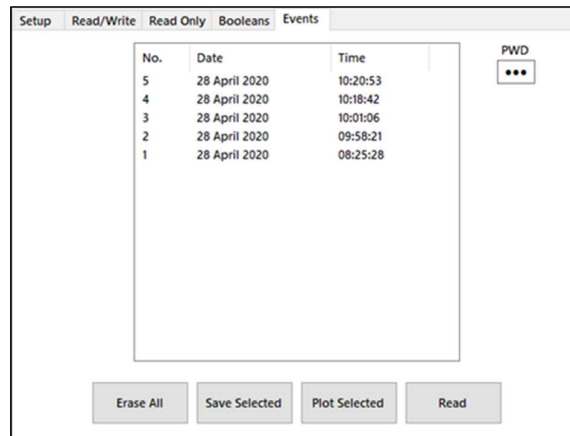

Once the list box has been populated the user can select one or multiple events in the list to either view graphically or download the event data to a file.

**PLOT** – Pressing the PLOT SELECTED button will download all the event data for each selected event and plot it graphically on the screen in a new window for each event. Each event log will take around 6 seconds to fully download so bear in mind when selecting multiple events. For a full description of the functionality of the Event View window refer to section 6.2.7 EVENT VIEW WINDOW

**SAVE** – Pressing the SAVE SELECTED button will download the event data for each selected event and save the data to a separate .csv file for each event. The .csv file can then be opened and analysed later using Excel. The .csv files will be automatically saved to ID5001P Config Outputs folder on the Desktop. Each event log will take around 6 seconds to fully download so bear in mind when selecting multiple events.

**ERASE** – Pressing the ERASE ALL button will clear the unit memory of all stored event data and reset the event count to 0. It is imperative that all the required event data has been recorded or downloaded before erasing the events as it may not be possible to recover the data.



### 6.2.6. LIVE DATA VIEW WINDOW

The Live Data View window can be used to monitor the sensor readings in real time at a rate of 2Hz. This screen can be particularly useful for debugging and testing purposes and can provide additional understanding of the theory of operation of the unit.

**PLOT** – Press the RUN button to begin plotting the live values on the screen. When running press STOP to stop plotting. The checkboxes provided along the bottom of the window can be used to enable or disable the particular plots on the chart.

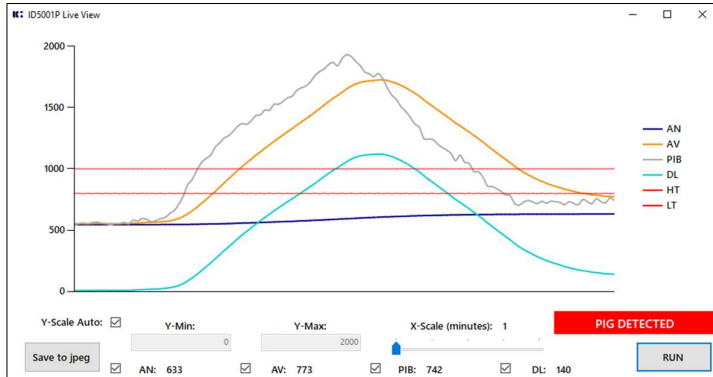

**SCALE** – The x-axis can be adjusted using the slider between 1 and 5 seconds. The y-axis is auto scale by default however it is possible to scale the y-axis manually if desired by unchecking the checkbox and entering the required min and max values into the textboxes provided.

**PIG DETECTION** – If a PIG event occurs and the unit enters DETECTION mode while the plot is being monitored then this will be indicated in the bottom right corner of the Live View screen by a flashing "PIG DETECTED" message highlighted in red as shown above.

**DATA LOGGING** – Each time the RUN button is pressed to start plotting a new .csv log file is created within ID5001P Config Outputs folder on the Desktop and all sensor values are logged continuously to the .csv file as long as the plot is running. This data file can then be opened and analysed later in Excel.

**SCREEN CAPTURE** – Pressing the SAVE TO JPEG button at any time will create a date and time stamped .jpeg image of the current Live View window and save this to the ID5001P Config Outputs folder on the Desktop.

### 6.2.7. EVENT VIEW WINDOW

The Event View window plots the PIG event data stored in the unit graphically on the screen to allow a quick way to view the data. The event data is not saved to the computer, this is just a viewing window. If the event data is required to be saved then the SAVE SELECTED button must be used on the Events tab as per section 6.2.5 EVENTS TAB

As indicated on the chart the event was triggered at time = 0 (point where DL drops below LT) and the previous 50 seconds of sensor data leading up to the event trigger are stored.

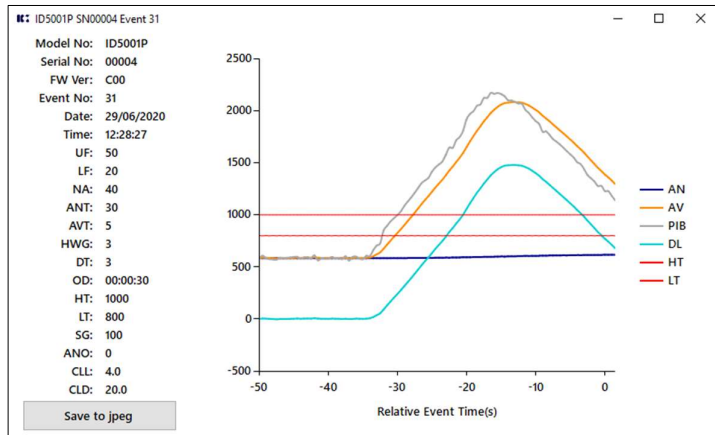

**SCREEN CAPTURE** – Pressing the SAVE TO JPEG button at any time will create a .jpeg image of the current Event View window and save this to the ID5001P Config Outputs folder on the Desktop.

## 7. RECOMMENDED MAINTENANCE & STORAGE

**⚠ WARNING:** The instructions detailed within the product certificate and the Special Conditions for Safe Use as detailed in section 10 CERTIFICATION APPENDIX of this manual must be followed at all times.

Frequent inspections should be made. A schedule for maintenance checks should be generated according to the environment and frequency of use but should be regular enough to ensure the equipment continues to operate in the designed manner. It is recommended that it should be at least once a year.

External parts of the equipment should be periodically cleaned using fresh water to ensure that deposits are not allowed to accumulate. Avoid the use of aggressive chemicals.

All external parts of the equipment should be periodically checked for corrosion or damage. If any damage is found, then the manufacturer must be contacted.

All components that are replaced must be in accordance with the manufacturers' specifications and instructions. Failure to do so may invalidate the certification/approval and may make the equipment dangerous.

If the unit is to be placed in storage for a long period of time ensure the unit has been cleaned, turned OFF and main batteries removed.

## 8. DISPOSAL OF UNIT

IK Trax takes its responsibilities under the WEEE Regulations extremely seriously and has taken steps to be compliant in line with our corporate and social responsibilities. In the UK, OEL has joined a registered compliance scheme WeeeCare (registration number **WEE/MP3538PZ/SCH**).

Electrical and electronic equipment should never be disposed of with general waste but must be separately collected for the proper treatment and recovery.

The crossed-out bin symbol, placed on the product, reminds you of the need to dispose of it correctly at the end of its life.

When buying a new product you will have the possibility to return, free of charge, another end of life product of equivalent type that has fulfilled the same functions as the supplied equipment. These items may be deposited at:

IK Trax  
Online House  
Woodburn Road  
Blackburn Business Park  
Blackburn  
Aberdeen  
AB21 0PS  
UK

Alternatively, to arrange a collection of any waste electrical equipment, obligated to IK Trax please telephone WeeeCare on **0844 800 2004**.

## 9. WARRANTY

IK Trax products are guaranteed for one year from the date of purchase. Goods should be returned transportation prepaid to IK Trax.

There is no charge for parts or labour should any product require repair due to a manufacturing deficiency during the guarantee period.

In the event of a manufacturing deficiency the inward transportation costs will be repaid to the client.

## 10. CERTIFICATION APPENDIX

**EQUIPMENT:** ID5001P Pig Signaller

**MANUFACTURER:** **Online Electronics Ltd**  
Online House  
Blackburn Business Park  
Woodburn Road  
Blackburn  
Aberdeen  
AB21 0PS  
UK

Tel: +44 (0) 1224 714 714  
Web: www.iktrax.com

**NOTIFIED BODY NUMBER:** 2812  
**UKEX NOTIFIED BODY NUMBER:** 0891

**ATEX CERTIFICATE:** TRAC 13 ATEX 0008X  
**UKEX CERTIFICATE:** EMA22UKEX0006X

**IECEX CERTIFICATE:** IECEx TRC 13.0006X

**MARKINGS:**  II 1/2 G Ex ia/db [ia Ga] IIC T4...T6 Ga/Gb

**APPLICABLE STANDARDS:** EN 60079-0:2018  
EN 60079-1:2014  
EN 60079-11:2012

IEC 60079-0:2017  
IEC 60079-1:2014  
IEC 60079-11:2011

### SPECIAL CONDITIONS FOR SAFE USE:

1. Do not open when an explosive gas atmosphere may be present.
2. Potential electrostatic charging hazard. The equipment should not be mounted in areas where it could be subjected to highly efficient charging mechanisms, such as fast moving dust or particle filled air, and shall only be cleaned with an anti-static or damp cloth.
3. Sensor, cable and electronics shall only be used as a complete assembly.
4. Internal and external threaded holes are provided for earthing and equipotential bonding. Protective earthing conductors employed shall be greater or equal to the size of the phase conductors, equipotential conductors shall have a minimum cross sectional area of 4mm<sup>2</sup>. The end user shall ensure conductors cannot be readily loosened or twisted. Light metals shall not be used unless special precautions are taken to guard against corrosion.
5. Any external power supply used with this equipment must have a rated output of 30 Vdc or less and comply with IEC 60950 series, IEC 62368 series, IEC 61010-1 or a technically equivalent standard.
6. External power and signals shall only be supplied according to manufacturers' instructions using suitable cable and suitable Ex certified cable glands.

7. External power and signals shall only be connected using suitable crimp ferrules to prevent accidental disconnection.
8. Unused cable entries shall be sealed using suitable Ex certified blanking elements.
9. The temperature at the cable entry point may exceed +70°C. Cables suitable for use at this temperature must be used.
10. Use only DURACELL INDUSTRIAL ID1300 **OR** SAFT LS33600 cells as indicated on the marking plate fitted to the rear endcap.
11. As part of the routine maintenance schedule, the condition of the window cement shall be periodically inspected for any degradation or discolouration of the cement that may compromise the explosion protection.
12. Sensor face must be positioned close to the pipeline surface and adequately protected from impacts.
13. Temperature class is reliant on the operating ambient temperature, the internal power dissipation (Pd) and whether internal cells are fitted.

<b>Pd</b>	<b>EXTERNAL SUPPLY (NO CELLS FITTED)</b>		
	<b>T4</b>	<b>T5</b>	<b>T6</b>
<1W	-40 to +85°C		-40 to +75°C
<5W			-40 to +70°C
<10W	-40 to +75°C	-40 to +70°C	-40 to +55°C

<b>Pd</b>	<b>DURACELL INDUSTRIAL ID1300 FITTED</b>		
	<b>T4</b>	<b>T5</b>	<b>T6</b>
<1W	-20 to +54°C		
<5W			
<10W			

<b>Pd</b>	<b>SAFT LS33600 FITTED</b>		
	<b>T4</b>	<b>T5</b>	<b>T6</b>
<1W	-40 to +85°C		-40 to +75°C
<5W			-40 to +70°C
<10W	-40 to +75°C	-40 to +70°C	-40 to +55°C