



TRAX

**Intelligent Pipeline
Technology**

ID5002P Operating Manual

Non-Intrusive Acoustic Pig Signaller



CONTENTS

Page

- 1. GENERAL DESCRIPTION 2
- 2. SPECIFICATIONS 3
- 3. RULES FOR SAFE OPERATION 4
- 4. OPERATION 5
 - 4.1. TURNING ON..... 5
 - 4.2. LISTENING 6
 - 4.3. DETECTION 6
 - 4.4. DETECTION ALGORITHM..... 7
 - 4.5. SINGLE BUTTON MENU SYSTEM 9
 - 4.5.1. MAIN MENU 10
 - 4.5.2. EVENTS MENU..... 11
 - 4.5.3. SYSTEM INFO MENU..... 12
 - 4.5.4. LIVE DISPLAY MENU 12
 - 4.5.5. OUTPUT CONFIG MENU 13
 - 4.5.6. DETECT CONFIG MENU..... 14
 - 4.6. RS485 SERIAL INTERFACE..... 15
 - 4.6.1. MODBUS REGISTER MAP 15
- 5. INSTALLATION 17
 - 5.1. MAIN HOUSING MOUNTING PLATE..... 17
 - 5.2. MAIN HOUSING POST MOUNTING..... 17
 - 5.3. MAIN HOUSING PIPELINE MOUNTING 18
 - 5.4. SENSOR MOUNTING 18
 - 5.5. SUNSHADE POST MOUNTING 19
 - 5.6. SUNSHADE PIPELINE MOUNTING..... 19
 - 5.7. OPENING THE HOUSING..... 20
 - 5.8. CLOSING THE HOUSING 20
 - 5.9. EXTERNAL CONNECTIONS 21
 - 5.9.1. 0V 22
 - 5.9.2. VIN 22
 - 5.9.3. EXTSW 22
 - 5.9.4. INTSW 22
 - 5.9.5. SEN+ / SEN- 22
 - 5.9.6. TRIG+ / TRIG- 22
 - 5.9.7. ENCLOSURE 22
 - 5.9.8. EX1..... 23
 - 5.9.9. CL+ / CL- 23
 - 5.9.10. RS485+ / RS485- / RS485G..... 23
 - 5.9.11. NC1 / COM1 / NO1 / NC2 / COM2 / NO2 23
- 6. ID5002P CONFIG APPLICATION 24
 - 6.1. APPLICATION INSTALLATION 25
 - 6.2. USING THE CONFIG APPLICATION 26
 - 6.2.1. SETUP TAB 26
 - 6.2.2. READ/WRITE TAB 27
 - 6.2.3. READ ONLY TAB 27
 - 6.2.4. BOOLEANS TAB 28
 - 6.2.5. EVENTS TAB 28
 - 6.2.6. LIVE VIEW WINDOW 29
 - 6.2.7. EVENT VIEW WINDOW 29
- 7. RECOMMENDED MAINTENANCE 30
- 8. DISPOSAL OF UNIT 31
- 9. WARRANTY 32
- 10. CERTIFICATION APPENDIX 33

Revision	Updated By	Description of Update	Update Date
B	BG	CR-24-01-04-01: Company logo update.	03/03/24
	AGO	CR-24-09-23-01: Application update	02/10/24

1. GENERAL DESCRIPTION

The ID5002P (Passive) is a fully ATEX and IECEx certified, Exia intrinsically safe, non-intrusive, pig signaller which detects, signals, and logs the passage of pigs at critical points along a pipeline both on land and offshore.

The unit uses Passive (listening) techniques to detect pig passage events. Events are signalled as they occur via a 3" graphical LCD display and high brightness LEDs positioned above and below the display. Events can also be signalled remotely using several optional outputs.

The unit logs the time and date of up to 99 events which can be viewed at any point using the local display. The user can turn the unit ON and OFF as well as modify several settings using a single control button and intuitive menu system.

The unit has two basic parts as shown below. The sensor is permanently connected to the main housing via a cable and can be quickly and easily attached to the pipeline using ratchet straps or steel banding. The main housing contains all electronics, display and the control button and can be mounted onto the pipeline using a mounting plate and straps in a similar fashion to the sensor or mounted on a wall or post.

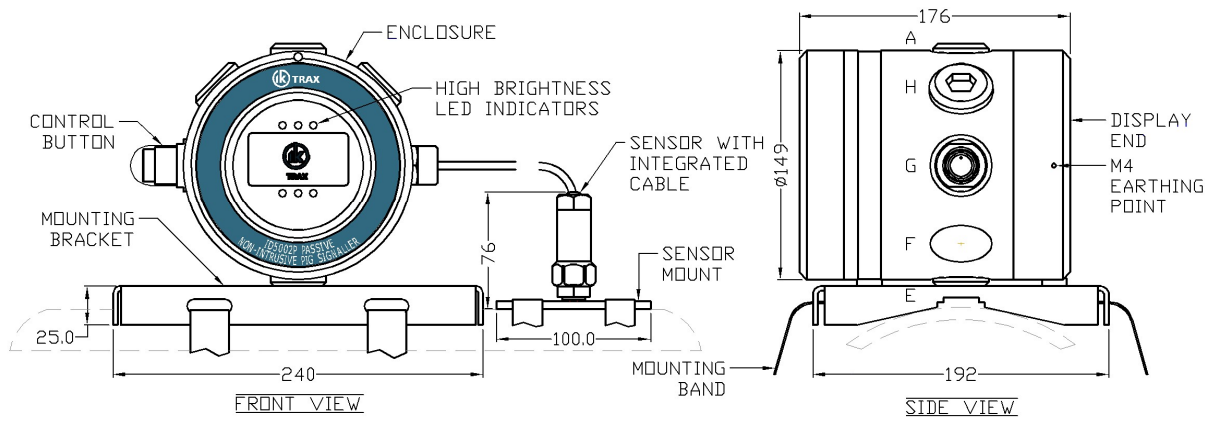

2. SPECIFICATIONS

GENERAL

External Supply	PSD5201 Intrinsically Safe Power Supply ^{NOTE1}
Main Housing Ambient Temperature Range	-40°C to +85°C
Sensor Ambient Temperature Range	-55°C to +110°C
Maximum Allowable Pipeline Surface Temperature	+150°C ^{NOTE2}
Typical minimum pig speed	0.1m/s ^{NOTE3}
Main Housing Ingress Protection	IP66
Sensor Ingress Protection	IP68
ATEX/IECEX code	 II 1 G Ex ia IIB T4 Ga
EU Type Examination Certificate Number	EMT16ATEX0007X
IECEX Certificate Number	IECEX EMT 16.0006X
Weight in Aluminium	8kg
Weight in Stainless Steel	13kg

OUTPUTS

DPDT Relay Output ^{NOTE4} (Volt Free Contacts)	2A @ 30VDC ^{NOTE5}
Current Loop Output	4-20mA ^{NOTE6}
Serial Data Interface	RS485 MODBUS

^{NOTE1} The ID5002P must be powered from a GM International PSD5201 power supply which may be purchased separately from IK Trax.

^{NOTE2} Maximum allowable pipeline surface temperature depends on ambient air temperature and mounting configuration. Only the sensor may be mounted on the pipeline.

^{NOTE3} Minimum pig speed depends on pig type, pipeline configuration and installation position.

^{NOTE4} DPDT is equivalent to 2x SPDT.

^{NOTE5} Limited by certification entity parameters.

^{NOTE6} Current Loop levels are configurable between 4mA and 20mA. Default set state 20.0mA. Default reset state 4.0mA. Tolerance ±1.0mA.

3. RULES FOR SAFE OPERATION

⚠ WARNING: The instructions detailed within the product certificate and the Special Conditions for Safe Use as detailed in section 10 CERTIFICATION APPENDIX of this manual must be followed at all times.

⚠ WARNING: The purchaser of this equipment is responsible for the training and competence of operators and the way in which it is used. This manual should be read through and understood before installation and commissioning so that the operator is familiar with the equipment. Contact IK Trax immediately should any difficulty arise in the use of this equipment.

4. OPERATION

Familiarise yourself with all of the rules for the safe operation of this equipment as described in section 3 RULES FOR SAFE OPERATION.

4.1. TURNING ON

Whenever power is applied to the unit it will turn on following the sequence of screens shown opposite.

When first turned on the COMPANY LOGO should appear for 5 seconds as shown by the COUNTDOWN INDICATOR located at the top left-hand side of the display.

When the COUNTDOWN INDICATOR reaches zero or the CONTROL BUTTON is pressed, the next screen will appear.

The next screen shows the PRODUCT LOGO and the currently installed firmware version at the bottom of the display.

The next screen shows the current system date and time. If the date and time are blank as shown then the date and time will require setting via the menu system or RS485 MODBUS serial interface.

The unit now enters STABILISATION. During STABILISATION the unit will initialise the detection filters and acquire the ambient noise level of the pipeline.

Once STABILISATION is complete the unit will enter LISTENING mode. In LISTENING mode, the display will be switched off and the LEDs will flash every 5 seconds to indicate that the unit is active. See section 4.2 LISTENING for more information.

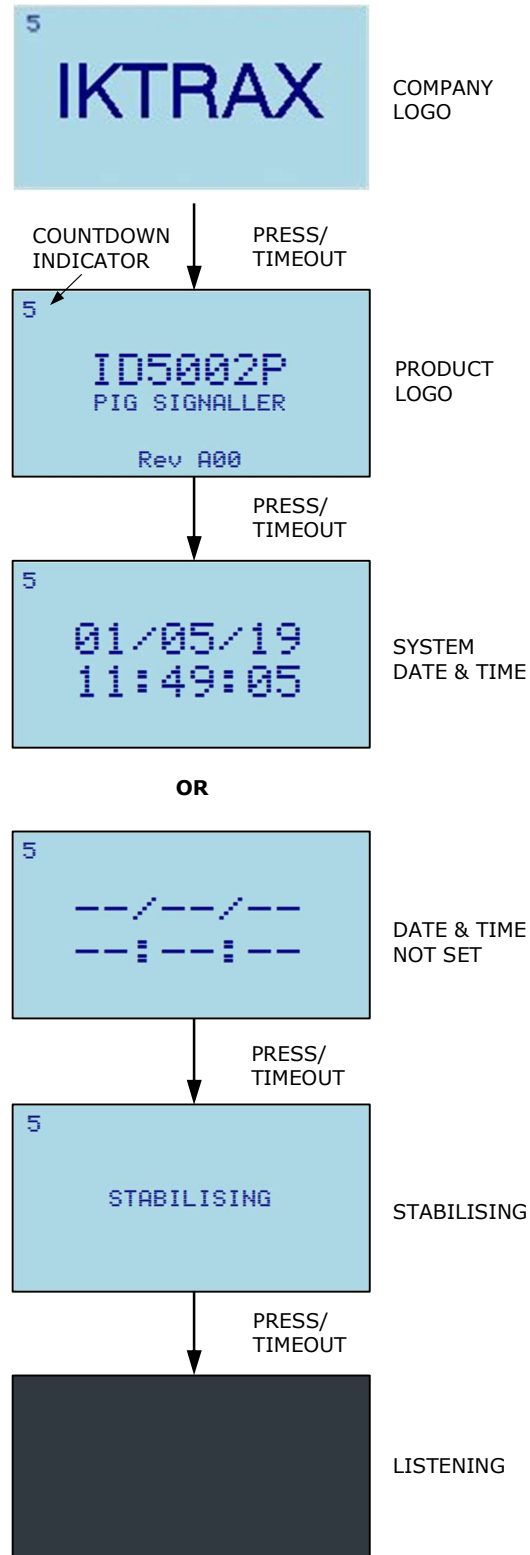

4.2. LISTENING

While in LISTENING mode the unit continuously monitors the acoustic energy produced by the pipeline as it waits for a pig passage to occur. The unit is configured to recognise the unique sound signature produced by a pig as it passes the sensor. The unit uses the algorithm described in section 4.4 DETECTION ALGORITHM to detect a pig passage.

While in LISTENING mode the display will be off and the LEDs above and below the display will flash every five seconds to indicate that the unit is active. The relay and current loop outputs will be in the LISTENING state.

There are two things that may cause the display to change:

CONTROL BUTTON – If the control button is pressed the unit will enter the MENU system. The menu system is described in section 4.5 SINGLE BUTTON MENU SYSTEM.

PIG APPROACH – If the unit detects a possible pig approaching the sensor then the display will show a PIG APPROACH message as shown. From this point the unit will continue running through the detection algorithm until either the approach is cancelled, in which case the display shall turn off, or it will signal pig detected as per section 4.3 DETECTION.



4.3. DETECTION

When a pig is detected the display will show a PIG DETECTED message including the date and time of the event as shown. The LEDs above and below the display will flash every second and the relay and current loop will be in the DETECTION state. The date and time of the pig passage are stored in internal memory and can be viewed later using the menu interface.



The unit will remain in the DETECTION state for the length of time defined by the OUTPUT DELAY before returning to LISTENING mode. The OUTPUT DELAY can be bypassed by pressing the CONTROL BUTTON.

OUTPUT DELAY – The OUTPUT DELAY controls how long the unit will signal an event for. Usually it will be configured to give the pig enough time to get out of range of the sensor after it has been detected to avoid re-trigger. When dealing with pig trains, the expected pig speed and separation should be used to configure a suitable value for the OUTPUT DELAY such that the unit will not detect the same pig twice but will enter LISTENING mode in time to detect the next pig.

LATCHED DETECTION – If the OUTPUT DELAY HH (hours) field is set to 99 then when an EVENT occurs the unit will LATCH in DETECTION mode showing the EVENT information and flashing the LEDs every 1 second. To begin LISTENING again the CONTROL BUTTON must be pressed or the detection reset using the serial interface.

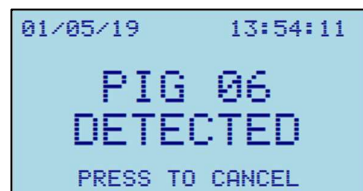

4.4. DETECTION ALGORITHM

Below is a simplified flowchart for the ID5002P detection algorithm which is running while the unit is in LISTENING mode.

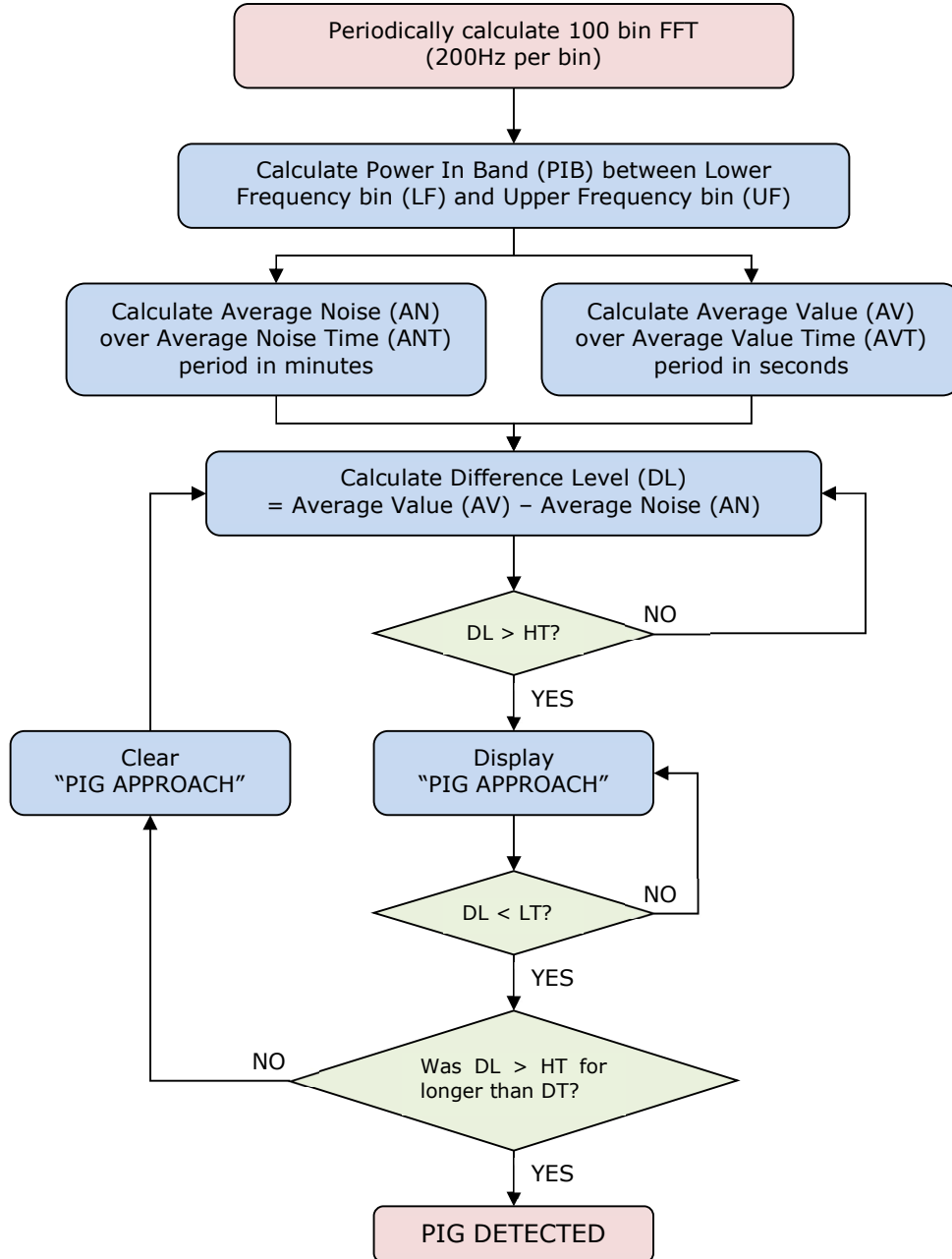

Below is a graphical representation a typical pig passage.

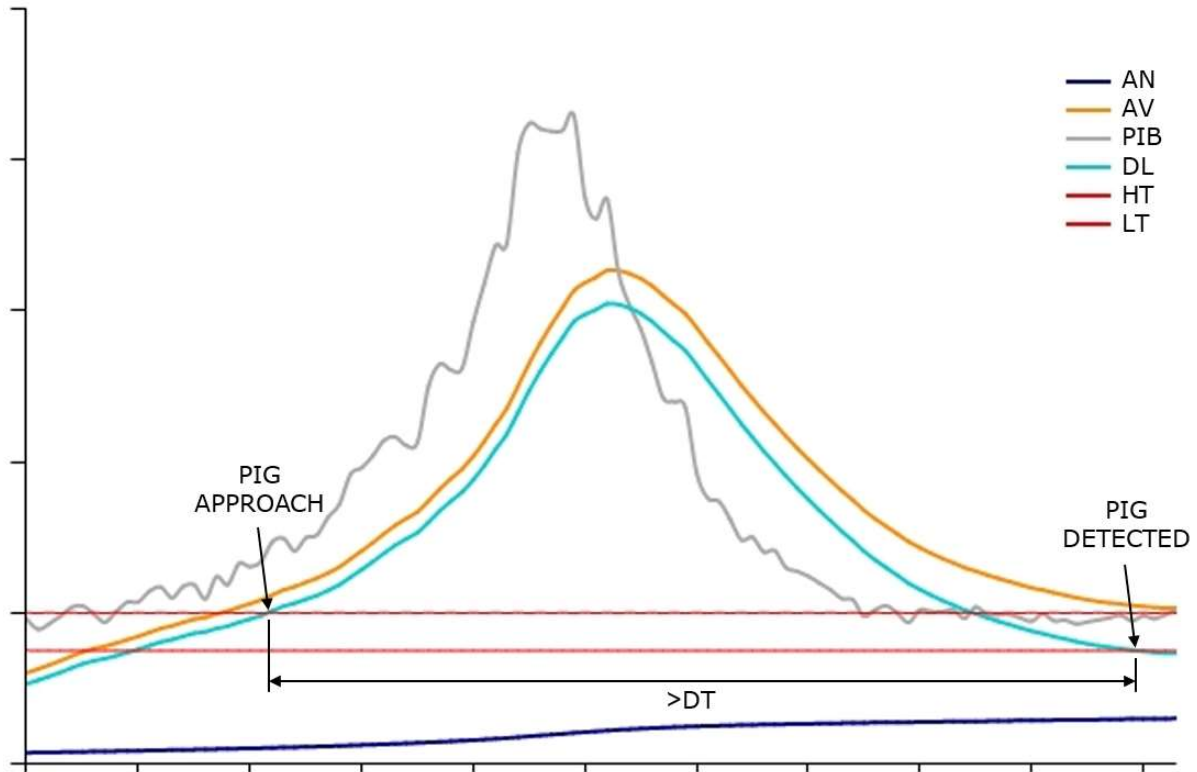

PIB	= Power In Band	(between Lower Frequency bin (LF) and Upper Frequency bin (UF))
AN	= Average Noise	(PIB averaged over Average Noise Time (ANT) period in minutes)
AV	= Average Value	(PIB averaged over Average Value Time (AVT) period in seconds)
DL	= Difference Level	(Average Value (AV) - Average Noise (AN))
HT	= High Threshold	(user set High Threshold)
LT	= Low Threshold	(user set Low Threshold)
DT	= Delta Time	(time DL is above HT before returning below LT must exceed DT seconds otherwise the approach will be cleared)

4.5. SINGLE BUTTON MENU SYSTEM

While LISTENING, the control button can be pressed to enter the menu interface. From the menu system the user can configure several parameters which are discussed in this section.

When any menu screen is loaded the cursor will initially be located at the home position at the top right corner next to the page number to indicate that the BACK action will occur when the countdown expires.

Pressing the control button causes the CURSOR to move down to the next menu item and the COUNTDOWN INDICATOR will be reset to 5. Once the CURSOR is pointing at the desired item the user simply allows the COUNTDOWN INDICATOR to reach 0 and the selected item will be executed. This simple behaviour is used throughout the menu interface to modify settings and interact with the unit.

If the active menu has multiple pages, as indicated in the top right-hand corner then when the last item is reached the next button press will load the next page and the cursor will return to the home position. When the end of the last page is reached then the unit will loop back to page 1 of the active menu.

If the selected item is a menu then when the countdown expires the new menu is loaded, otherwise if the item is an editable field then the display will go into edit mode to allow the value to be changed. In edit mode the part of the field actively being edited is enclosed in a box to highlight it. Some parameters will provide additional information on screen while editing such as min and max values. All parameters are incremented by pressing the CONTROL BUTTON until they are at the desired value. Allowing the COUNTDOWN INDICATOR to reach 0 either selects the next editable digit in the field if there is one, otherwise edit mode will exit and the new value will be saved.

If while editing a parameter value you wish to cancel the edit operation, then press and hold the CONTROL BUTTON until the cursor returns to the home position.

If an item was selected accidentally then simply press and hold the CONTROL BUTTON until the cursor returns to the home position or allow the COUNTDOWN INDICATOR to reach 0 without pressing the CONTROL BUTTON.

The menu system is designed so that the unit will always return to LISTENING mode if the CONTROL BUTTON is left released for a long enough time.

Below is the typical layout of a menu screen:

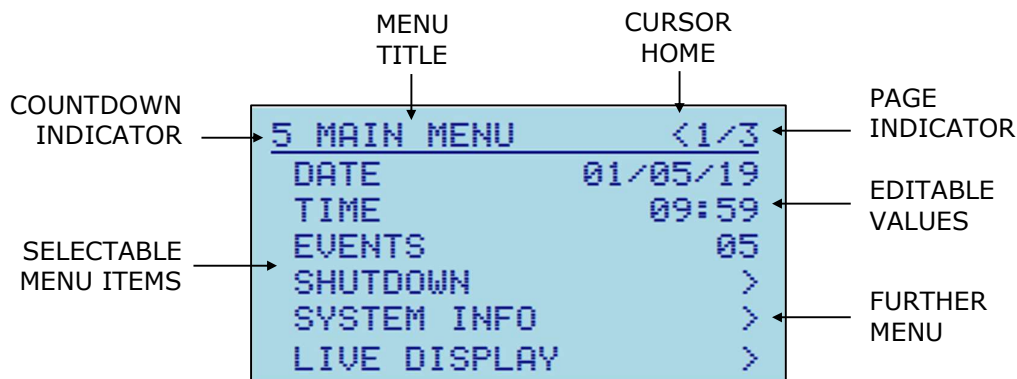

4.5.1. MAIN MENU

The MAIN MENU is the initial entry point to the menu system. This menu consists of three pages as shown.

DATE – Select this item to edit the system date. Ensure that a valid date is entered in DD/MM/YY format.

TIME – Select this item to edit the system time. Ensure that a valid time is entered in 24hour HH:MM format. Seconds will be set to 0 when the time edit completes.

EVENTS – Indicates the number of stored events. Select this item to view or delete events via the EVENTS menu. See section 4.5.2 EVENTS MENU.

SHUTDOWN – Select this item to switch off the unit. The unit has memory backup and will remember all settings until next time the unit is switched on. It is imperative that the unit is turned off using this command rather than simply disconnecting the external power supply to allow any memory storage processes to complete prior to turning OFF. Once turned off the unit can be turned back on either by pressing the CONTROL BUTTON for 5 seconds or by cycling the external power supply.

SYSTEM INFO – Select this item to access the System Info menu. See section 4.5.3 SYSTEM INFO MENU.

LIVE DISPLAY – Select this item to access the Live Display menu. See section 4.5.4 LIVE DISPLAY MENU.

OUTPUT CONFIG – Select this item to configure the output functionality of the unit. See section 4.5.5 OUTPUT CONFIG MENU.

DETECT CONFIG – Select this item to configure the detection parameters used by the unit to detect pig passages. See section 4.5.6 DETECT CONFIG MENU.

MODBUS ADDRESS – Select this item to edit the RS485 MODBUS slave address (1 – 247).

LANGUAGE – Select this item to change the system language.

FORMAT SD CARD – Select this item to format the internal SD card (if fitted).

The following LCD parameters will require the user to press the CONTROL BUTTON within 5 seconds, to save after editing the value. This feature is to try and prevent the display becoming unreadable. If after editing a value the display is unreadable then just let the countdown timeout and the previous value will be reloaded.

LCD CONTRAST – Select this item to edit the LCD contrast (65 – 99%).

LCD BL FREQ – Select this item to edit the LCD backlight frequency (100 – 200Hz).

LCD BL DUTY – Select this item to edit the LCD backlight duty cycle (1 – 99%).

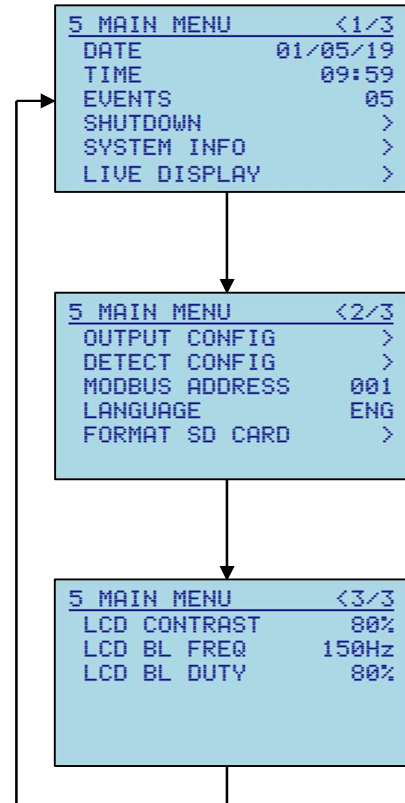

4.5.2. EVENTS MENU

The EVENTS MENU allows the user to view and erase the EVENTS stored in the unit memory.

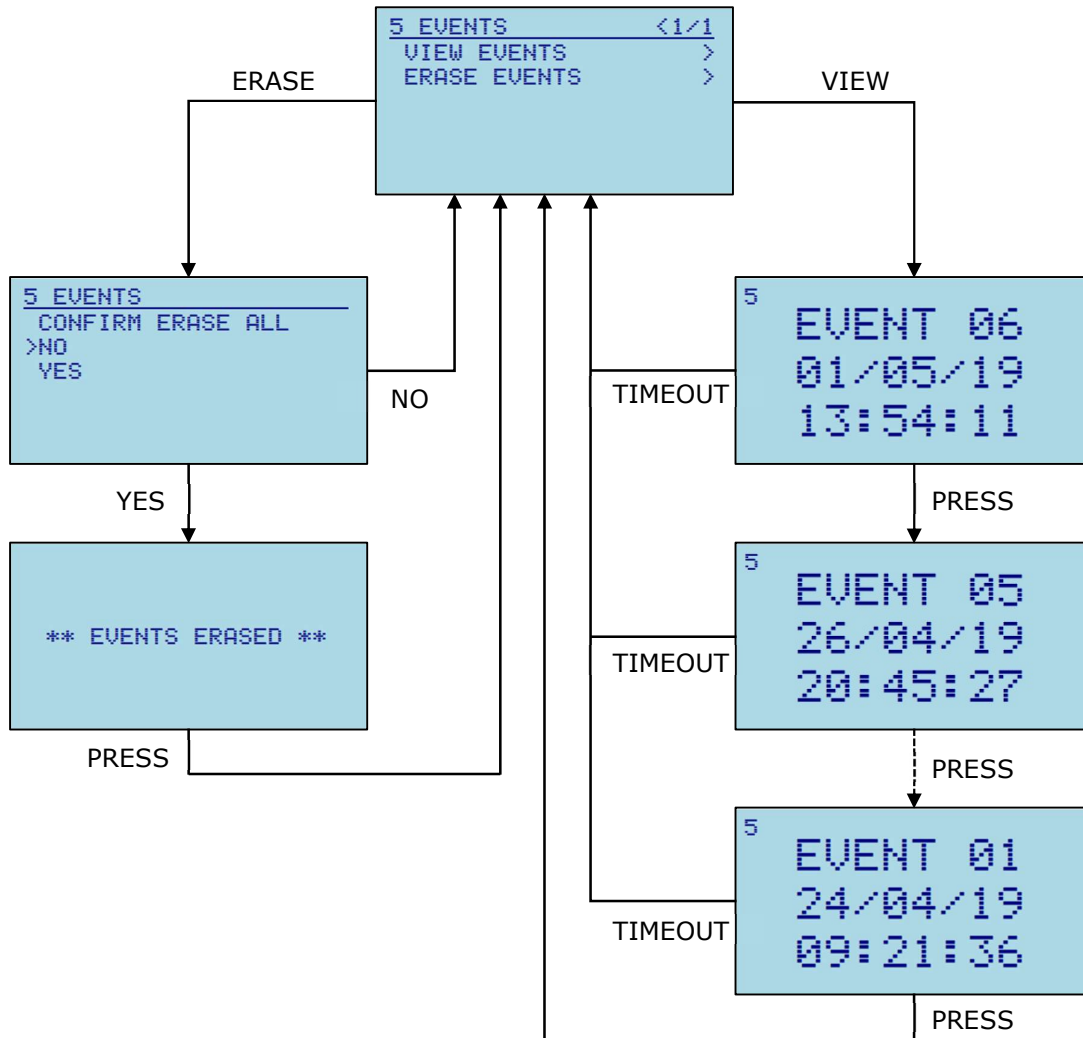

VIEW EVENTS – Selecting this item will allow the user to cycle through all logged EVENTS from newest to oldest. The EVENT number, date and time are shown. Pressing the CONTROL BUTTON will cycle to the next event. The CONTROL BUTTON can be held to pause at any event. If the COUNTDOWN INDICATOR reaches 0 then the unit will return to the EVENTS MENU.

ERASE EVENTS – Selecting this item will ERASE all logged EVENT data. The user will be prompted to confirm this action before proceeding with the ERASE as this action cannot be undone. To cancel the ERASE simply ensure NO is selected before the countdown expires. If YES is selected, then a message will appear to indicate that the EVENTS have been erased before returning to the EVENTS MENU.

4.5.3. SYSTEM INFO MENU

The SYSTEM INFO MENU is used to display certain system parameters to the user.

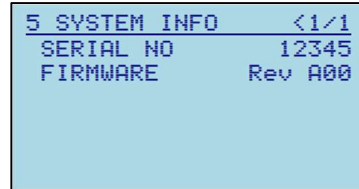

SERIAL NO – READ ONLY – The unit serial number is configured at time of manufacture.

FIRMWARE – This item shows the currently installed firmware version. Select this item to upgrade the unit firmware via USB. This action will require confirmation from the user before proceeding as the unit will be locked up in the bootloader until either a new firmware image is uploaded, or the unit power is cycled. This procedure should only be undertaken by IK Trax staff or following instruction from IK Trax.

4.5.4. LIVE DISPLAY MENU

The LIVE DISPLAY MENU gives the user access to the three available diagnostic screens. These screens allow the user to view the live signals being monitored by the unit which is useful to confirm correct operation and when making changes to the detection parameters.

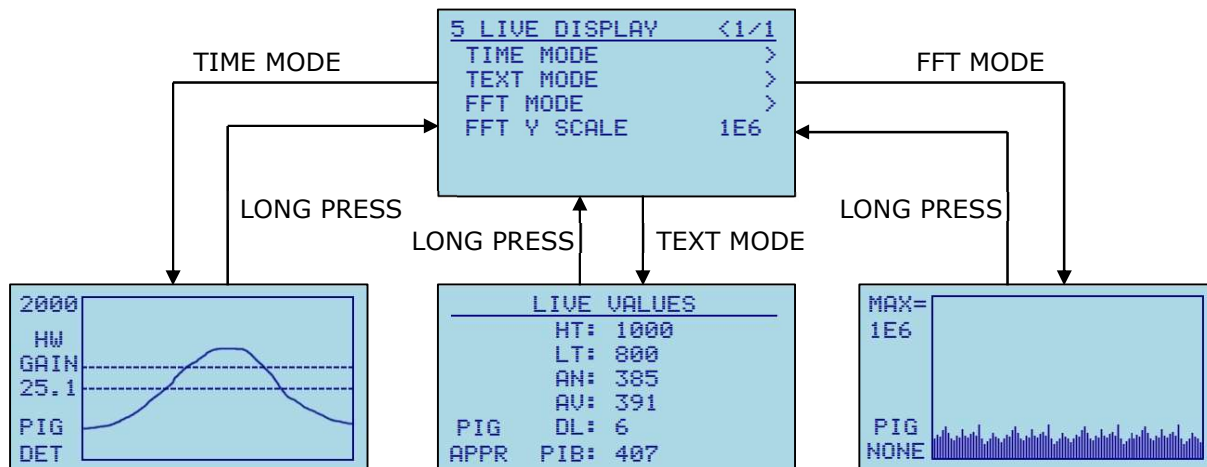

TIME MODE – This mode displays a live graphical plot of the Difference Level (DL) vs time. The High Threshold (HT) and the Low Threshold (LT) are indicated by the dashed lines. The Y axis is auto scaling based on the maximum value of Difference Level (DL).

TEXT MODE – This mode shows the following live values in text form: Low Threshold (LT), High Threshold (HT), Average Noise (AN), Average Value (AV), Difference Level (DL) and Power In Band (PIB).

FFT MODE – This mode displays a live graphical plot of the full FFT bandwidth (0 – 20kHz). There are 100 points along the X axis, each representing a 200Hz FFT bin result.

FFT Y SCALE – Selecting this item allows the user to edit the Y scale for the FFT plot. The Y scale can be set to either AUTO or to one of the predefined maximum values. Due to the limited space on the display the available maximum values are defined in the following way: 1E4 = 1x10⁴ = 10000, 2E4 = 2x10⁴ = 20000 etc.

When viewing a live screen, the pig passage status shall be indicated in the lower left corner by either of the following messages: "PIG NONE" (Listening), "PIG APPR" (Pig Approaching) or "PIG DET" (Pig Detected).

Pressing the CONTROL BUTTON while the unit is in APPROACH or DETECT mode will return the unit to LISTENING mode. A LONG BUTTON PRESS is required to exit the live display screen and return to the menu system.

4.5.5. OUTPUT CONFIG MENU

The OUTPUT CONFIG MENU allows the user to configure the output functionality of the unit. This menu consists of two pages as shown.

OUTPUT DELAY – Select this item to modify the OUTPUT DELAY in HH:MM:SS format. The OUTPUT DELAY dictates how long the unit will indicate DETECTION before returning to LISTENING mode. This can take any value from 00:00:00 up to 98:59:59.

CL OUTPUT – Select this item to enable or disable the CURRENT LOOP output functionality. If the CURRENT LOOP output is disabled the loop current will be 2mA, otherwise, the loop current will be either the user defined LISTENING or DETECTION level.

CL LISTEN – Select this item to edit the CURRENT LOOP LISTENING level (4.0 – 20.0mA).

CL DETECT – Select this item to edit the CURRENT LOOP DETECTION level (4.0 – 20.0mA).

RELAY INVERT – Select this item to enable or disable the inverse operation of the relay.

LED FLASH – Select this item to enable or disable the flashing high brightness LEDs fitted above and below the LCD display.

LED LATCH – Select this item to enable or disable the LED LATCH feature. If LED LATCH is enabled then during DETECTION the LEDs will latch on instead of flashing every second.

VAL SD LOG – Select this item to enable or disable logging of the raw data to the internal SD card (if fitted). It is imperative that the unit is shutdown correctly using the menu system before removing the SD card otherwise the log file will not be terminated correctly and all recorded data may be permanently lost.

FFT SD LOG – Select this item to enable or disable logging of the FFT data to the internal SD card (if fitted). It is imperative that the unit is shutdown correctly using the menu system before removing the SD card otherwise the log file will not be terminated correctly and all recorded data may be permanently lost.

RESET TO DEFAULTS – Selecting this item will reset all output parameters to their default values. This option requires the user to confirm before it is actioned.

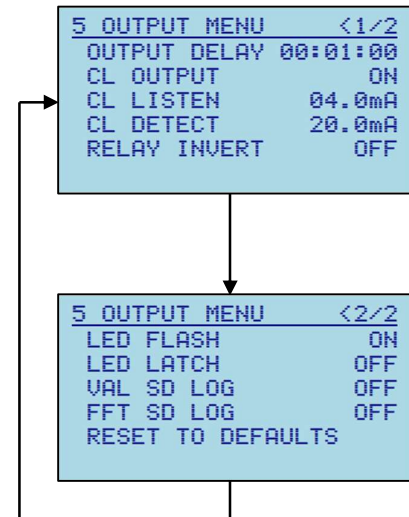

4.5.6. DETECT CONFIG MENU

ADJUSTING THESE PARAMETERS WITHOUT FIRST CONSULTING IK Trax MAY CAUSE THE UNIT TO MISS PIG PASSAGES OR GIVE FALSE DETECTIONS.

The DETECT CONFIG MENU allows the user to configure the detection parameters for the unit. This menu consists of three pages as shown.

HIGH THRESHOLD – The Difference Level (DL) must exceed this threshold before the unit will consider a possible pig approach. (0 – 65535)

LOW THRESHOLD – The Difference Level (DL) must fall below this threshold after being above High Threshold (HT) to trigger a pig detection. (0 – 65535)

DELTA TIME – The length of time the Difference Level (DL) must be above the Low Threshold (LT) after exceeding the High Threshold (HT) before the unit will indicate a detection. If the time does not exceed this value, then the pig approach will be cancelled. (1 – 100 seconds)

AV VALUE TIME – The time period the Power In-Band (PIB) is averaged over to calculate the Average Value (AV). (1 – 100 seconds)

AV NOISE TIME – The time period the Power In-Band (PIB) is averaged over to calculate the Average Noise (AN). (1 – 100 minutes)

AV NOISE OVER – The value of Average Noise (AN) can be over ridden by the user, if this value is set to zero then the calculated Average Noise (AN) will be used. (0 – 65535)

NUM AVERAGES – The number of samples that will be averaged to calculate the Power In-Band (PIB). Increasing this value will smooth the resultant PIB output waveform at the expense of increased processing time to compute the FFTs. (1 – 50)

UPPER FREQ BIN – The highest frequency bin to be included in the Power In-Band (PIB). 200Hz/bin (1 – 100)

LOWER FREQ BIN – The lowest frequency bin to be included in the Power In-Band (PIB). 200Hz/bin (1 – 100)

HARDWARE GAIN – The hardware gain configuration. (1 – 4)

SENSOR GAIN – The sensor gain level. (1 – 12000)

HP FILTER – Enables or disables the hardware high pass filter stage.

RESET TO DEFAULTS – Selecting this item will reset all detection parameters to their default values. This option requires the user to confirm before it is actioned.

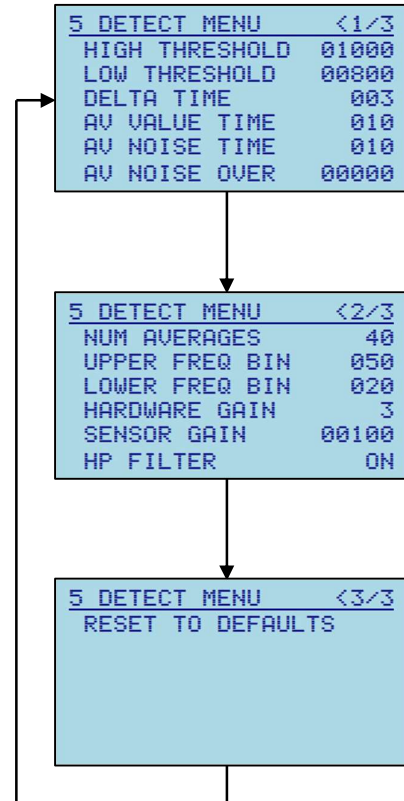

4.6. RS485 SERIAL INTERFACE

Communication to the ID5002P, via the RS485 interface, makes use of MODBUS RTU protocol. All the parameters available in the ID5002P menu system can also be accessed via the MODBUS interface. The serial interface should be configured as follows:

9600 baud, 8 data bits, 1 stop bit, no parity

⚠ WARNING: Care should be taken when remotely controlling/configuring the unit via the MODBUS interface as values set intentionally, or unintentionally, will immediately affect the operation of the ID5002P. E.g. enabling relay inversion, although a useful test, will cause the relay to switch and signal an event when no event is active.

4.6.1. MODBUS REGISTER MAP

COILS		
0	Log Values to SD card	Write 1 to enable or 0 to disable
1	Log FFT to SD card	Write 1 to enable or 0 to disable
2	Invert Relay Operation	Write 1 to enable or 0 to disable
3	LED Latch Enable	Write 1 to enable or 0 to disable
4	Current Loop Enable	Write 1 to enable or 0 to disable
5	High Pass Filter Enable	Write 1 to enable or 0 to disable
6	LED Flash Enable	Write 1 to enable or 0 to disable
15	Pig Detected	Read Only – Pig detection status
16	Reset Detect Parameters	Write 1 to reset detect parameters
17	Reset Output Parameters	Write 1 to reset output parameters
18	Erase Events	Write 1 to erase the stored events

INPUT REGISTERS		
0	Average Noise (AN) High	Upper word (bits 31:16)
1	Average Noise (AN) Low	Lower word (bits 15:0)
2	Average Value (AV) High	Upper word (bits 31:16)
3	Average Value (AV) Low	Lower word (bits 15:0)
4	Difference Level (DL) High	Upper word (bits 31:16)
5	Difference Level (DL) Low	Lower word (bits 15:0)
6	Power In-Band (PIB) High	Upper word (bits 31:16)
7	Power In-Band (PIB) Low	Lower word (bits 15:0)
8	Number of Events	0 - 99
14	Firmware Type	5002
15	Firmware Revision	Major Rev ASCII (bits 15:8) Minor Rev (bits 7:0)
16	Event Year	Selected event date
17	Event Month	Selected event date
18	Event Day	Selected event date
19	Event Hour	Selected event time
20	Event Minutes	Selected event time
21	Event Seconds	Selected event time
22	CPU Temperature	°C
25	Unit Serial No	0 - 65535

HOLDING REGISTERS		
0	Upper Freq Bin (UF)	0 - 100 (200Hz/bin)
1	Lower Freq Bin (LF)	0 - 100 (200Hz/bin)
2	Number of Averages (NA)	1 - 50
3	Average Noise Time (ANT)	1 - 100 minutes
4	Average Value Time (AVT)	1 - 100 seconds
5	Hardware Gain (HG)	1 - 4
6	Delta Time (DT)	1 - 100 seconds
7	Output Delay Hours	0 - 99 hours
8	Output Delay Minutes	0 - 59 minutes
9	Output Delay Seconds	0 - 59 seconds
10	High Threshold (HT)	0 - 65535
11	Low Threshold (LT)	0 - 65535
12	Sensor Gain (SG)	1 - 12000
13	Average Noise Override (ANO)	0 - 65535
14	Current Loop Listening Level	Val = $(I_{mA} \times 65536)/24$
15	Current Loop Detected Level	Val = $(I_{mA} \times 65536)/24$
16	LCD Contrast	65 - 99
17	LCD Backlight	Freq = Val/100, Duty = Val%100
18	MODBUS Slave Address	1 - 247
19	Language	0 = ENG, 1 = FRA, 2 = ESP
32	System Year	System date
33	System Month	System date
34	System Day	System date
35	System Hour	System time
36	System Minute	System time
37	System Second	System time
38	Selected Event Number	0 - 99, Input registers selected event number

5. INSTALLATION

⚠ WARNING: The instructions detailed within the product certificate and the Special Conditions for Safe Use as detailed in section 10 CERTIFICATION APPENDIX of this manual must be followed at all times.

Normally the unit is used to confirm whether or not a pig has passed a known point of interest on a pipeline such as a bend or valve. The unit should be mounted approximately 5m after the point of interest and a test run completed to confirm successful installation and reliable detection.

If the main housing is exposed to direct sunshine then it is recommended that a sunshade is installed to prevent unnecessary heating of the unit which may shorten the lifespan of the equipment. See sections 5.5 SUNSHADE POST MOUNTING and 5.6 SUNSHADE PIPELINE MOUNTING.

5.1. MAIN HOUSING MOUNTING PLATE

The unit is supplied with a mounting plate as shown which is suitable for use with ratchet straps or steel banding and for mounting the unit onto pipelines, posts and walls.

If the unit is post mounted then 4x M8x120 coach bolts should be fitted as per 5.2 MAIN HOUSING POST MOUNTING prior to attaching the mounting plate.

The mounting plate is attached to the main housing as shown using 2x M8x16 bolts / 2x M8 spring washers / 2x M8 plain washers / mounting plate / 2x M8x5 spacers / main electronics housing.

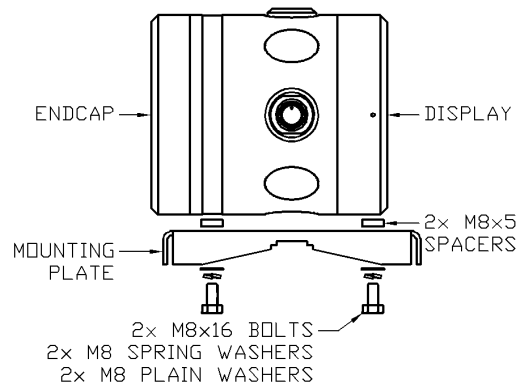

5.2. MAIN HOUSING POST MOUNTING

The post mounted unit is supplied with a post mounting assembly as shown.

1. Prior to fitting the mounting plate as per 5.1 MAIN HOUSING MOUNTING PLATE pass the 4x M8x120 coach bolts through the mounting plate.
2. Hold the assembly in position on the post and secure using 4x M8 nuts / 4x M8 washers / post mount clamp / post / mounting plate / 4x M8x120 coach bolts as shown (view from above).
3. If equipotential bonding or earthing is required then the M4 threads around the perimeter of the display endcap may be used.

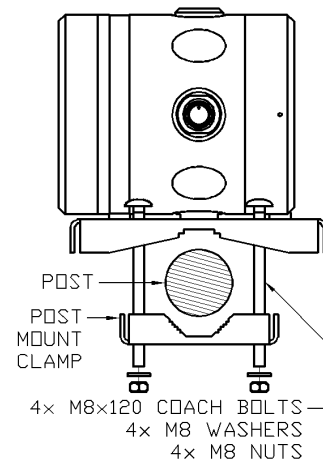

5.3. MAIN HOUSING PIPELINE MOUNTING

The pipeline mounted unit is supplied with a set of ratchet straps or steel banding as shown.

1. If the pipeline surface temperature is expected to exceed +85°C then the housing must NOT be fitted on the pipeline.
2. Ensure the mounting plate is securely fitted to the housing as per 5.1 MAIN HOUSING MOUNTING PLATE.
3. Temporarily place the unit at the chosen location to ensure that the unit sits in place without rocking excessively.
4. Thread 2x loops of banding through the slots provided in the mounting plate as shown and then following the instructions provided with the banding gradually tighten the banding until the unit is held firmly. Do not use excessive force.
5. If equipotential bonding or earthing is required then the M4 threads around the perimeter of the display endcap may be used.

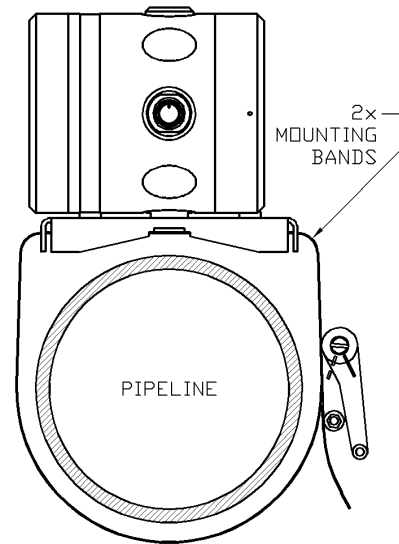

5.4. SENSOR MOUNTING

For optimum results, ensure that the pipeline surface at the point of installation is uniform, clean and smooth. If the surface is irregular, corroded, or has flaking paint, then an abrasive paper or wire brush should be used to prepare the surface. The unit will operate effectively through most painted layers as long as they are clean, uniform and are fully bonded to the pipeline surface, however in the case of surface coatings which contain air gaps, foam coatings, concrete coatings, thermally insulating coatings or composite coatings consisting of several materials with different densities, an area of coating should be removed to allow installation of the sensor directly onto the bare pipeline surface.

The sensor is supplied with a mounting plate, a mounting stud, a PEEK insulator (if required) and a length of mounting band.

1. If the pipeline surface temperature is expected to exceed +85°C then the sensor must be fitted on the lower half of the pipeline as shown to minimise convection heating and a PEEK insulator must be fitted to thermally insulate the sensor from the pipeline. IK Trax should be contacted for further guidance. Do NOT exceed 3Nm tightening torque if using the PEEK insulator or the threads may be damaged.
2. Pass the mounting stud or insulator (if required) through the $\varnothing 6\text{mm}$ hole in the mounting band and then screw into the mounting plate approximately 4 full turns. Do not tighten further at this point.
3. Loop the mounting band around the pipeline and then following the instructions provided with the banding gradually tighten the banding until the mounting assembly is held firmly. Do not use excessive force.
4. Ensure that the mounting plate is positioned to form a cross with the mounting band and the mounting band has been firmly tightened before fully

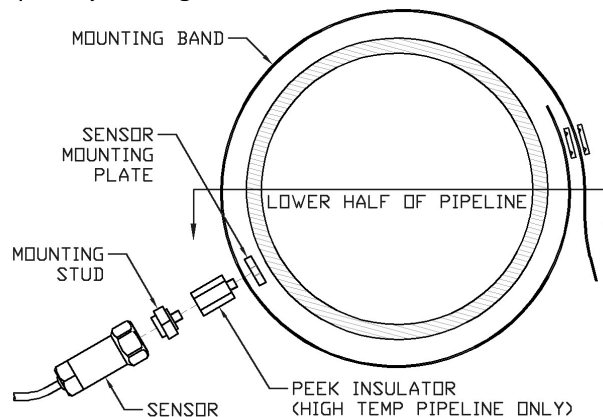

tightening the mounting stud into the mounting plate using a 21mm AF wrench or the insulator (if required) using a 15mm AF wrench. Do NOT exceed 3Nm tightening torque if using the PEEK insulator or the threads may be damaged. It should not be possible to move the mounting plate at this point.

5. Attach the ID5002P sensor to the mounting stud tightening using a 1" AF wrench. Do NOT exceed 3Nm tightening torque if using the PEEK insulator or the threads may be damaged.

5.5. SUNSHADE POST MOUNTING

If the main housing is exposed to direct sunshine then it is recommended that a sunshade is installed to prevent unnecessary heating of the unit which may shorten the lifespan of the equipment.

Secure the post mount sunshade to the post as shown using the supplied M8 U-bolt / post / clamp / sunshade / 2x M8 washers / 2x M8 nuts.

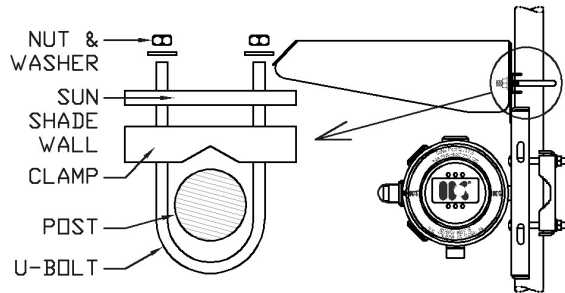

5.6. SUNSHADE PIPELINE MOUNTING

If the main housing is exposed to direct sunshine then it is recommended that a sunshade is installed to prevent unnecessary heating of the unit which may shorten the lifespan of the equipment.

The pipeline mounted sunshade is fixed to the same mounting plate as the main unit using 2x 'C' brackets as shown. This assembly is then mounted onto the pipeline as described in section 5.3 MAIN HOUSING PIPELINE MOUNTING.

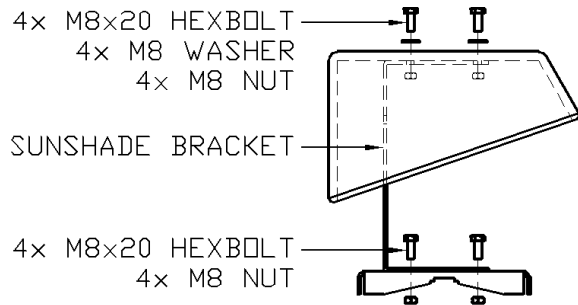

Secure 2x pipeline mount sunshade brackets to the mounting plate using 4x M8x20 hexbolts / 2x 'C' brackets / mounting plate / 4x M8 nuts.

Secure the sunshade to the 2x brackets using 4x M8x20 hexbolts / 4x M8 washers / sunshade / 2x 'C' brackets / 4x M8 nuts.

5.7. OPENING THE HOUSING

⚠ WARNING: The instructions detailed within the product certificate and the Special Conditions for Safe Use as detailed in section 10 CERTIFICATION APPENDIX of this manual must be followed at all times.

1. **⚠ WARNING – DO NOT OPEN WHEN ENERGIZED.**
2. Using a 3mm AF allen key loosen the M4 locking screw located at the 12 o'clock position on the rear endcap 6x full turns.
3. Carefully unscrew the rear endcap while being prepared to take the weight when it disengages. There are 4x unthreaded holes around the perimeter of the endcap which may be used should leverage be required.

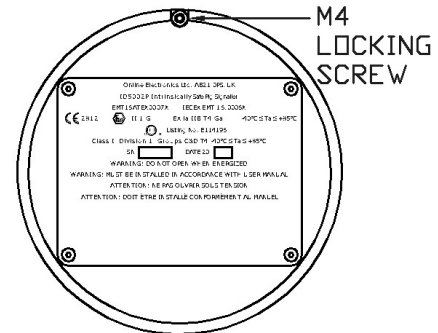

5.8. CLOSING THE HOUSING

1. Gently hand tighten the rear endcap. Do not use tools or over tighten otherwise the endcap will be difficult to remove. The M4 locking screw should be at the 12 o'clock position when the endcap is fully engaged, there should still be a small gap (<0.5mm) between the endcap and housing.
2. Using a 3mm AF allen key gently tighten the M4 locking screw located at the 12 o'clock position on the rear endcap. Do not over tighten, very little torque is required to lock the endcap in place.

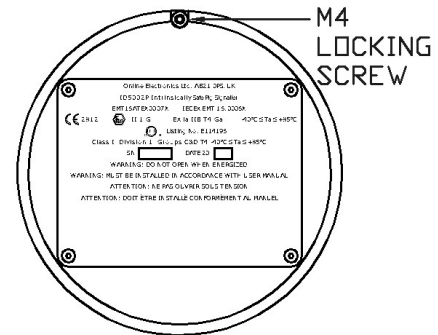

5.9. EXTERNAL CONNECTIONS

⚠ WARNING: The instructions detailed within the product certificate and the Special Conditions for Safe Use as detailed in section 10 CERTIFICATION APPENDIX of this manual must be followed at all times.

Remove the endcap as described in section 5.7 OPENING THE HOUSING to reveal the PCB connections.

All connections are made using 5.08mm pitch removable terminal blocks which can accept up to 2.5mm² (14AWG) wire size. All connections must be made using suitable crimp ferrules. Connections are clearly labelled on the PCB and have the functions described in the following sections.

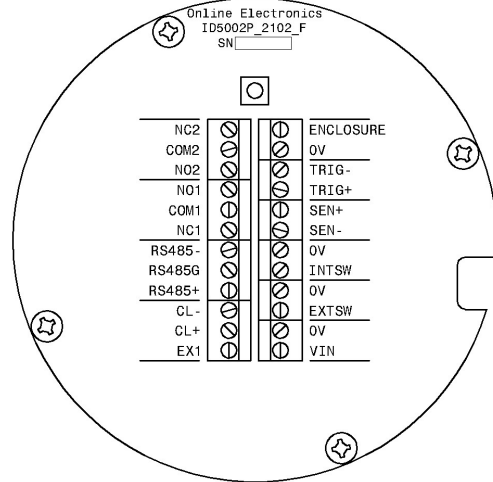

An example of the recommended wiring for an ID5002P system is shown below.

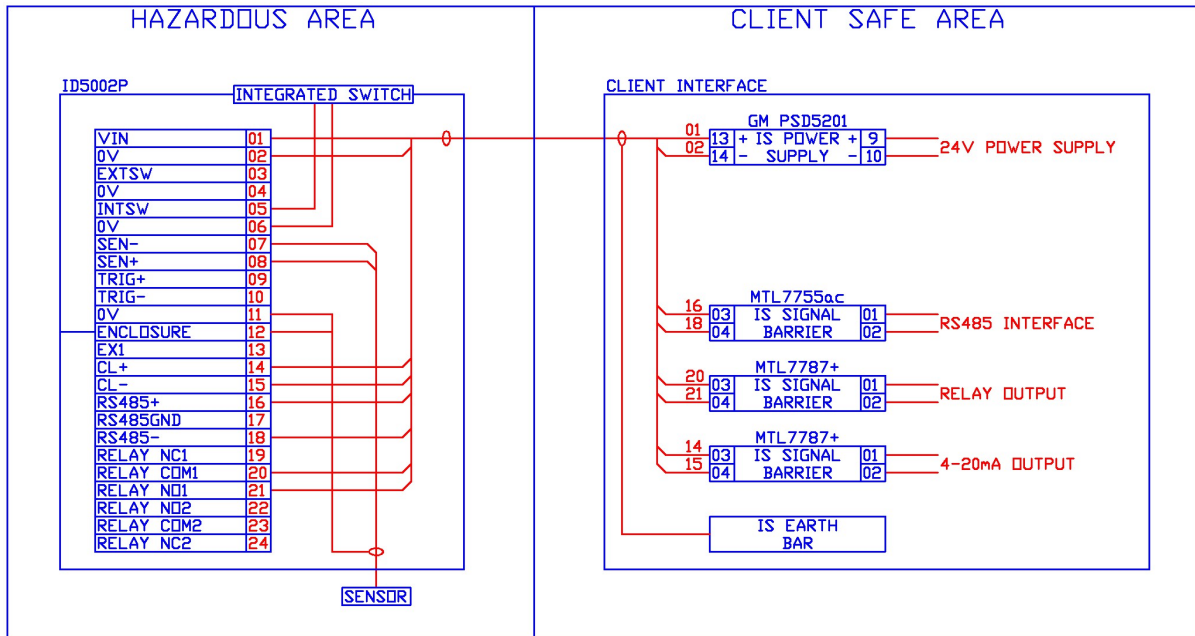

5.9.1. 0V

0V is the 0V reference for the internal PCBs. 0V should be linked to the ENCLOSURE connection to improve electrical noise immunity.

5.9.2. VIN

VIN is connected to the positive side of the external DC supply. The negative side of the external DC supply is connected to 0V.

A GM International, PSD5201, intrinsically safe, isolated, power supply must be used at all times.

VIN is not isolated from 0V however the use of a PSD5201 supply provides isolation from earth.

5.9.3. EXTSW

Do not use the EXTSW connection.

EXTSW is not isolated from 0V.

5.9.4. INTSW

The ID5002P is supplied with a suitable, momentary, NO switch connected between INTSW and 0V.

INTSW is not isolated from 0V.

5.9.5. SEN+ / SEN-

The ID5002P is supplied with a suitable sensor connected between SEN+ and SEN-.

The sensor is supplied with a shielded cable. The cable shield is connected to the sensor body which is isolated from SEN+ and SEN-. The cable shield is connected to the main housing using a suitable gland.

SEN+ / SEN- are not isolated from 0V.

5.9.6. TRIG+ / TRIG-

Do not use the TRIG+ / TRIG- connections.

TRIG+ / TRIG- are isolated from 0V and all other connections.

5.9.7. ENCLOSURE

ENCLOSURE provides an electrical connection to the main housing. ENCLOSURE should be linked to the 0V connection to improve electrical noise immunity.

ENCLOSURE is isolated from 0V (unless a link is fitted between 0V and ENCLOSURE).

If equipotential bonding or earthing is required then there are 2x M4 threads around the perimeter of the display endcap. As per e.g. EN60079-14:2008 section 12.2.4 the ID5002P must be isolated from earth or connected at one point to the equipotential bonding system.

5.9.8. EX1

Do not use the EX1 connection.

EX1 is isolated from 0V and all other connections.

5.9.9. CL+ / CL-

CL+ / CL- provide a current loop output for remote signalling.

CL+ is connected to the current loop supply (in to unit).

CL- is connected to the current loop return (out of unit).

CL+ / CL- are isolated from 0V and all other connections.

When the unit is switched on and the CL function is disabled the CL output will consume 2.0mA.

When the unit is switched on and the CL function is enabled then the CL output will consume either the LISTENING or DETECTION level current depending on the state of the signaller.

While in the LISTENING state, the CL output will consume the user configurable LISTENING current (4.0mA default).

While in the DETECTION state, the CL output will consume the user configurable DETECTION current (20.0mA default).

5.9.10. RS485+ / RS485- / RS485G

RS485+ / RS485- / RS485G provide an RS485 interface for remote signalling and interaction with the unit.

RS485+ / RS485- / RS485G are isolated from 0V and all other connections.

5.9.11. NC1 / COM1 / NO1 / NC2 / COM2 / NO2

The relay output is DPDT (Double Pole Double Throw) meaning that there are two separate sets of contacts (NC1 / COM1 / NO1 and NC2 / COM2 / NO2) which is equivalent to 2x SPDT (Single Pole Double Throw). These may be connected to two separate external circuits.

Contact rating is 30VDC @ 2A. Allowable input parameters are limited by section 10 CERTIFICATION APPENDIX.

Contact sets NC1 / COM1 / NO1 and NC2 / COM2 / NO2 are isolated from each other, 0V and all other connections.

While in the LISTENING state, the Normally Closed contacts of the relays will be connected to their respective Common contacts and the Normally Open contacts will be open.

While in the DETECTION state, the Normally Closed contacts of the relays will be open, and the Normally Open contacts will be connected to their respective Common contacts.

6. ID5002P CONFIG APPLICATION

The ID5002P Config application is used to monitor and configure ID5002P Pig Signallers over the RS485 serial interface.

The application allows the user access to the following items remotely from a computer:

- Set system date and time
- Configure all system, output and detection parameters
- Monitor PIG detection status
- Monitor live sensor values
- View and download PIG event data from the unit memory

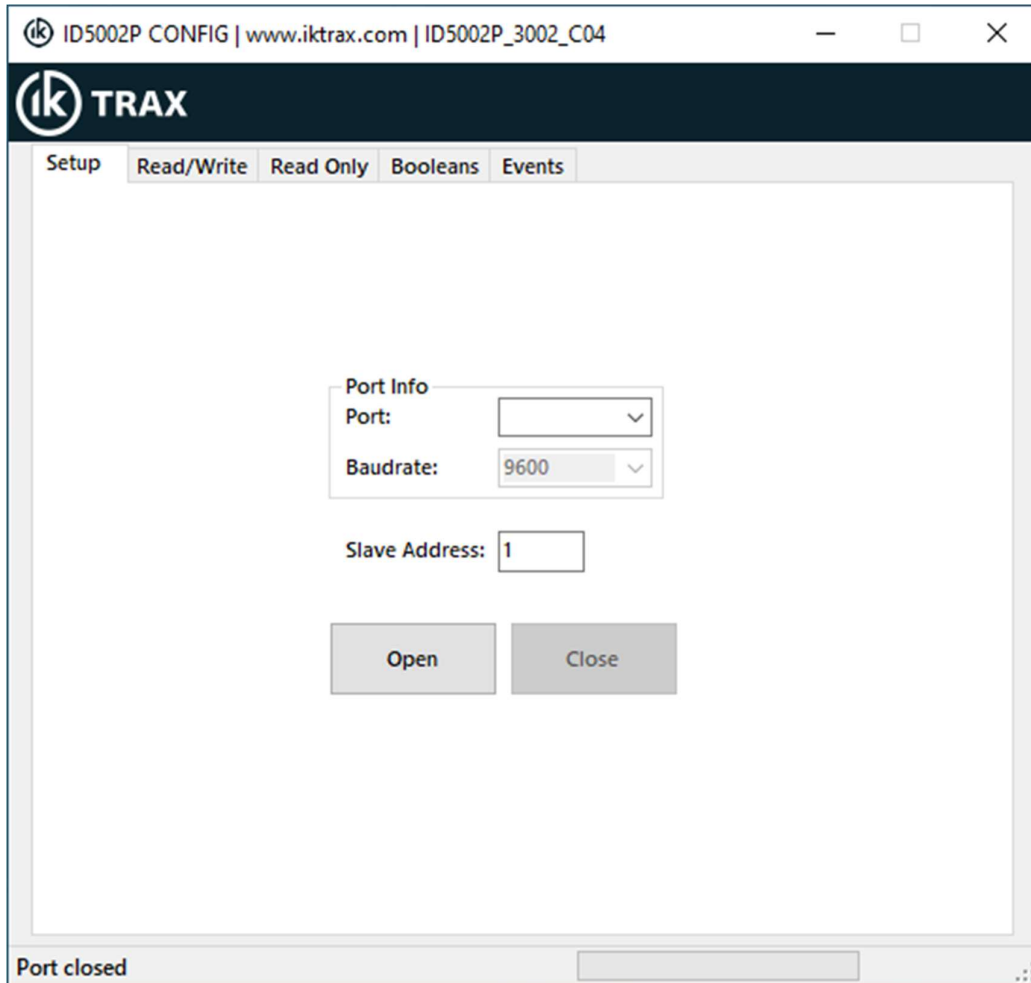

6.1. APPLICATION INSTALLATION

Ensure that the application has been installed and tested in advance of when it will actually be required.

The application requires the Microsoft .NET Framework to be installed on the host PC. Depending on which operating system is running on the host PC it may be necessary to upgrade to the latest version of the .NET framework by visiting <https://dotnet.microsoft.com/download>.

The installation folder for the application has typical name ID5002P_3002_C04 ID5002P CONFIG WINDOWS INSTALL which represents the full application name and version.

The typical size of the installation folder is 1MB.

Simply unzip the folder if applicable, save the folder into any location on the target device, run the setup.exe file found within the folder and then follow the instructions when prompted. A shortcut to the application will be automatically added to the Start menu and desktop.

6.2. USING THE CONFIG APPLICATION

⚠ WARNING: Care should be taken when remotely controlling/configuring the unit as values set intentionally, or unintentionally, will immediately affect the operation of the ID5002P. E.g. enabling relay inversion, although a useful test, will cause the relay to switch and signal an event when no event is active. It is recommended that the user familiarise themselves with the operation of the ID5002P and the config application in a test environment before using it to configure a unit in the field.

The config application opens in a window that contains multiple tabs that can be selected to view the different types of information available. The function of each tab is described in the following sections.

6.2.1. SETUP TAB

When the application launches the initial tab will be the Setup tab.

Ensure the USB to RS485 cable has been plugged into the computer and any driver installation has completed.

PORT - Select the appropriate COM Port from the drop down list the click OPEN to open the port. If the port has opened successfully a message will be displayed in the status bar located in the bottom left corner of the application window.

BAUD RATE - Currently 9600 is the only supported baud rate.

SLAVE ADDRESS - If there are multiple devices on the RS485 bus then each will require to have a unique slave address configured to allow communications to function correctly. The default slave address configured for all devices at time of manufacture is 1. This text box allows the user to select which slave device the application will be communicating with. Address 0 has a special broadcast function which can be used to write data to all devices simultaneously, this could be useful for synchronising date and time for example. Only write operations can use broadcast, read operations are not possible as it is impossible to receive a response from all slave devices simultaneously.

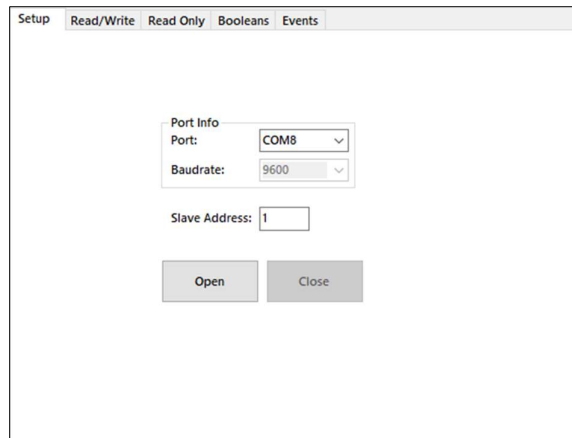

6.2.2. READ/WRITE TAB

The Read/Write tab is used to configure all the numerical parameters that can be both read from and written to.

For a full description of each parameter refer to sections 4.5.5 OUTPUT CONFIG MENU and 4.5.6 DETECT CONFIG MENU

READ – Pressing the READ button will read all Read/Write parameter values from the unit.

WRITE – In order to write a new value to the unit select the checkbox next to the value you wish to edit, amend the value in the Value cell then press the WRITE SELECTED button. If the write is successful a message will be displayed in the status bar located in the bottom left corner of the application window.

SYNC DATE & TIME – Pressing the SYNC TO PC TIME button will send the current PC date and time to the unit.

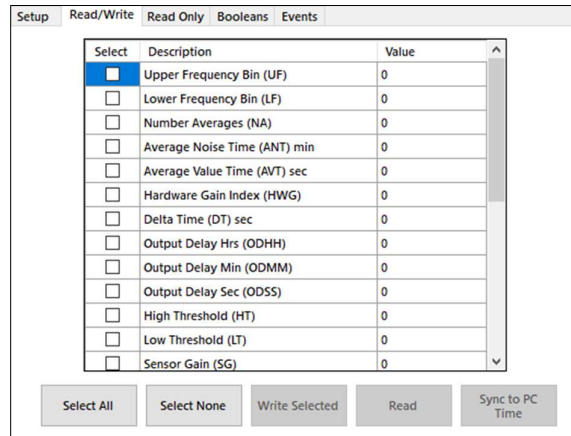

6.2.3. READ ONLY TAB

The Read Only tab displays all the read only parameters which include the pig detection status, live sensor values and various system parameters.

READ – Pressing the READ button will read all the Read Only parameter values from the unit.

POLL – Pressing the POLL button will read all the read only values continuously at rate of 2Hz.

PLOT – Pressing the PLOT button will open a new window that will show a graphical plot of the live sensor values on the screen. For a full description of the functionality of the Live Data View window refer to section 6.2.6 LIVE DATA VIEW WINDOW

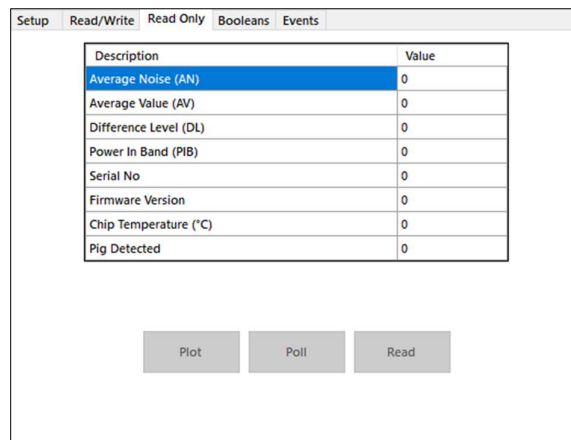

6.2.4. BOOLEANS TAB

The Booleans tab is used to configure all the boolean parameters that can be both read from and written to.

For a full description of each parameter refer to sections 4.5.5 OUTPUT CONFIG MENU and 4.5.6 DETECT CONFIG MENU.

READ – Pressing the READ button will read all boolean parameter values from the unit.

WRITE – In order to write a new value to the unit select the checkbox to the left of the value you wish to edit, amend the value in the On cell by either checking or unchecking the box then press the WRITE SELECTED button. If the write is successful a message will be displayed in the status bar located in the bottom left corner of the application window.

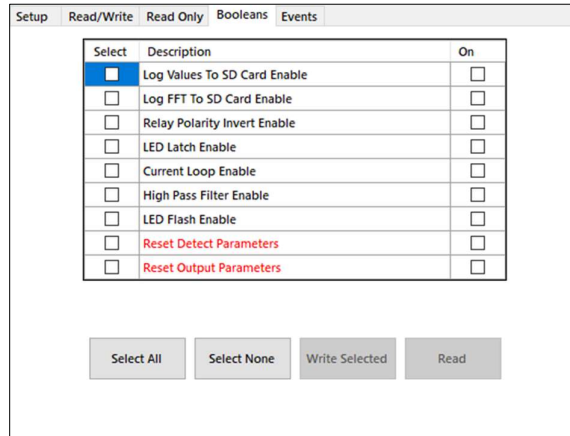

6.2.5. EVENTS TAB

The Events tab is used to view and download PIG event data from the unit.

For each PIG event the unit stores a header containing a date & time stamp and setting configuration together with 104 sets of sensor readings prior to the event trigger point.

READ – Pressing the READ button will read all logged PIG event headers and display all the date & time stamps in the list box. If there are a large number of events recorded it may take a few seconds to read all the event header data from the unit and populate the list box.

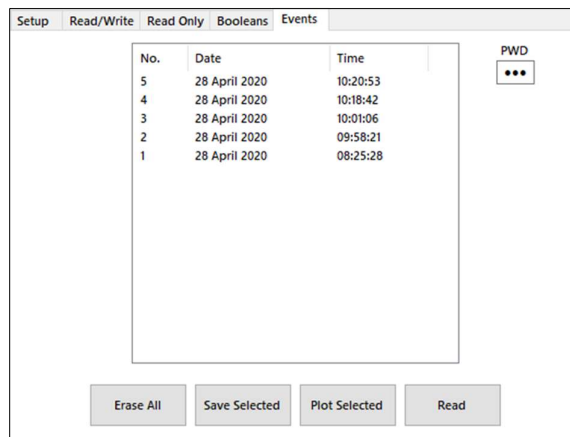

Once the list box has been populated the user can select one or multiple events in the list to either view graphically or download the event data to a file.

PLOT – Pressing the PLOT SELECTED button will download all the event data for each selected event and plot it graphically on the screen in a new window for each event. Each event log will take around 6 seconds to fully download so bear in mind when selecting multiple events. For a full description of the functionality of the Event View window refer to section 6.2.7 EVENT VIEW WINDOW.

SAVE – Pressing the SAVE SELECTED button will download the event data for each selected event and save the data to a separate .csv file for each event. The .csv file can then be opened and analysed later using Excel. The .csv files will be automatically saved to ID5002P Config Outputs folder on the Desktop. Each event log will take around 6 seconds to fully download so bear in mind when selecting multiple events.

ERASE – Pressing the ERASE ALL button will clear the unit memory of all stored event data and reset the event count to 0. It is imperative that all the required event data has been recorded or downloaded before erasing the events as it may not be possible to recover the data.

6.2.6. LIVE DATA VIEW WINDOW

The Live Data View window can be used to monitor the sensor readings in real time at a rate of 2Hz. This screen can be particularly useful for debugging and testing purposes and can provide additional understanding of the theory of operation of the unit.

PLOT – Press the RUN button to begin plotting the live values on the screen. When running press STOP to stop plotting. The checkboxes provided along the bottom of the window can be used to enable or disable the particular plots on the chart.

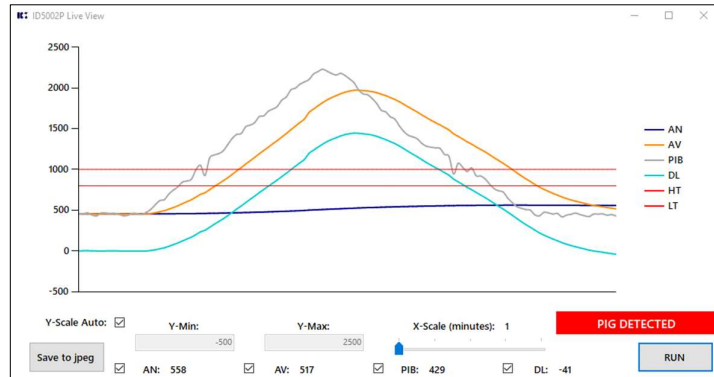

SCALE – The x-axis can be adjusted using the slider between 1 and 5 seconds. The y-axis is auto scale by default however it is possible to scale the y-axis manually if desired by unchecking the checkbox and entering the required min and max values into the textboxes provided.

PIG DETECTION – If a PIG event occurs and the unit enters DETECTION mode while the plot is being monitored then this will be indicated in the bottom right corner of the Live View screen by a flashing "PIG DETECTED" message highlighted in red as shown above.

DATA LOGGING – Each time the RUN button is pressed to start plotting a new .csv log file is created within ID5002P Config Outputs folder on the Desktop and all sensor values are logged continuously to the .csv file as long as the plot is running. This data file can then be opened and analysed later in Excel.

SCREEN CAPTURE – Pressing the SAVE TO JPEG button at any time will create a date and time stamped .jpeg image of the current Live View window and save this to the ID5002P Config Outputs folder on the Desktop.

6.2.7. EVENT VIEW WINDOW

The Event View window plots the PIG event data stored in the unit graphically on the screen to allow a quick way to view the data. The event data is not saved to the computer, this is just a viewing window. If the event data is required to be saved then the SAVE SELECTED button must be used on the Events tab as per section 6.2.5 EVENTS TAB.

As indicated on the chart the event was triggered at time = 0 (point where DL drops below LT) and the previous 50 seconds of sensor data leading up to the event trigger are stored.

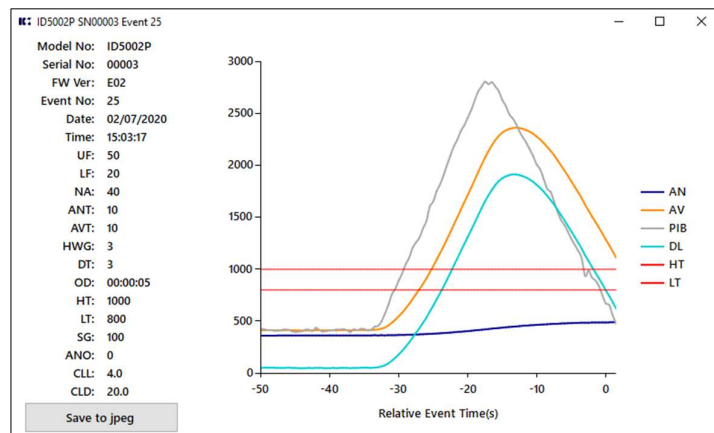

SCREEN CAPTURE – Pressing the SAVE TO JPEG button at any time will create a .jpeg image of the current Event View window and save this to the ID5002P Config Outputs folder on the Desktop.

7. RECOMMENDED MAINTENANCE

⚠ WARNING: The instructions detailed within the product certificate and the Special Conditions for Safe Use as detailed in section 10 CERTIFICATION APPENDIX of this manual must be followed at all times.

Frequent inspections should be made. A schedule for maintenance checks should be generated according to the environment and frequency of use but should be regular enough to ensure the equipment continues to operate in the designed manner. It is recommended that it should be at least once a year.

External parts of the equipment should be periodically cleaned using fresh water to ensure that deposits are not allowed to accumulate. Avoid the use of aggressive chemicals.

All external parts of the equipment should be periodically checked for corrosion or damage. If any damage is found then the manufacturer must be contacted.

All components that are replaced must be in accordance with the manufacturers' specifications and instructions. Failure to do so may invalidate the certification/approval and may make the equipment dangerous.

8. DISPOSAL OF UNIT

IK Trax takes its responsibilities under the WEEE Regulations extremely seriously and has taken steps to be compliant in line with our corporate and social responsibilities. In the UK, IK Trax has joined a registered compliance scheme WeeeCare (registration number **WEE/MP3538PZ/SCH**).

Electrical and electronic equipment should never be disposed of with general waste but must be separately collected for the proper treatment and recovery.

The crossed-out bin symbol, placed on the product, reminds you of the need to dispose of it correctly at the end of its life.

When buying a new product you will have the possibility to return, free of charge, another end of life product of equivalent type that has fulfilled the same functions as the supplied equipment. These items may be deposited at:

Online Electronics Ltd
Doing business as IK Trax
Woodburn Road
Blackburn Business Park
Blackburn
Aberdeen
AB21 0PS
UK

Alternatively, to arrange a collection of any waste electrical equipment, obligated to IK Trax please telephone WeeeCare on **0844 800 2004**.

9. WARRANTY

IK Trax products are guaranteed for one year from the date of purchase. Goods should be returned transportation prepaid to IK Trax.

There is no charge for parts or labour should any product require repair due to a manufacturing deficiency during the guarantee period.

In the event of a manufacturing deficiency the inward transportation costs will be repaid to the client.

10. CERTIFICATION APPENDIX

EQUIPMENT: ID5002P Pig Signaller

MANUFACTURER: **Online Electronics Ltd**
Online House
Blackburn Business Park
Woodburn Road
Blackburn
Aberdeen
AB21 0PS
UK
Tel: +44 (0) 1224 714 714
Web: www.online-electronics.com

NOTIFIED BODY NUMBER: 2812

ATEX CERTIFICATE: EMT16ATEX0007X

IECEX CERTIFICATE: IECEX EMT 16.0006X

MARKINGS:  II 1 G Ex ia IIB T4 Ga -40°C ≤ Ta ≤ +85°C

APPLICABLE STANDARDS: EN 60079-0:2012/A11:2013
EN 60079-11:2012
IEC 60079-0:2011
IEC 60079-11:2011

POLLUTION DEGREE: 2 (IEC 60664-1)

OVERVOLTAGE CATEGORY: I/II (IEC 60664-1)

SPECIAL CONDITIONS FOR SAFE USE:

1. WARNING: Do not open when energized.
2. WARNING: Must be installed in accordance with user manual.
3. All intrinsically safe installations must be in accordance with the assembly and installation regulations described in IEC 60079-14.
4. Refer to the provided parameter tables for external connection parameters.
5. Cable glands used with this equipment must be IECEX/ATEX approved with IP66 rating or greater and be selected with consideration of the expected environmental conditions at the point of installation.
6. This equipment contains an internal SD card that must not be accessed or removed or replaced in a hazardous area.
7. This equipment contains a USB port that must only be used by the manufacturer during production, test, repair and overhaul of the equipment in a safe area. It is not intended to be used by the end-user in a hazardous or non-hazardous area at any time.
8. Aluminium versions may present a spark hazard and must only be installed in hazardous areas such that the ignition sources due to impact and friction are excluded.

9. Painted or powder coated versions may present an electrostatic charging hazard and should not be mounted in areas where they could be subjected to highly efficient charging mechanisms, such as fast moving dust or particle filled air, and shall only be cleaned with an anti-static or damp cloth.
10. As part of a routine maintenance schedule, the condition of the window cement shall be periodically inspected for any degradation or discolouration of the cement that may compromise the explosion protection.
11. As per IEC/EN 60079-14 the ID5002P shall be either isolated from earth or connected at one point to the equipotential bonding system.
12. If enclosure equipotential bonding or earthing is connected then to avoid double earth faults the EXTSW connection must not be connected to a second earth.

PARAMETER TABLES:

The ID5002P must be connected via suitably certified intrinsically safe barriers satisfying the following parameters unless otherwise stated:

Description	Power Supply	RS485	4-20mA Current Loop	Internal Switch	External Switch	Remote Switch	Sensor
Terminals	VIN 0V	RS485+ RS485- RS485GND	CL+ CL-	INTSW 0V	EXTSW 0V	TRIG+ TRIG-	SEN+ SEN-
Ui	21.5V	6.0V	29.4V	- NOTE1	0V	29.4V	-
Ii	604mA	600mA	125mA	- NOTE1	0mA	125mA	-
Pi	3243mW	450mW	920mW	- NOTE1	0W	650mW	-
Ci (int)	0µF	110nF	121nF	- NOTE1	0µF	0µF	-
Li (int)	0µH	0µH	0µH	- NOTE1	0µH	0µH	-
Uo	-	-	-	- NOTE1	4.1V	-	23.1V
Io	-	-	-	- NOTE1	5mA	-	28mA
Po	-	-	-	- NOTE1	5mW	-	160mW
Co (ext)	-	-	-	- NOTE1	10uF	-	1.02µF
Lo (ext)	-	-	-	- NOTE1	0.2H	-	0.19H
Example Accessory NOTE3	GM PSD5201	MTL 7755ac	MTL 7787+	NA NOTE1	GM D1044S	MTL 7787+	NA NOTE2

Description	Relay								
Terminals	NO1, COM1, NC1 NO2, COM2, NC2								
Ui	15.0V	OR	21.6V	OR	24.0V	OR	30.0V	OR	45.0V
Ii	2000mA		611mA		433mA		253mA		113mA
Pi	7500mW		3299mW		2958mW		1897mW		1271mW
Ci	0µF		0µF		0µF		0µF		0µF
Li	0µH		0µH		0µH		0µH		0µH
Example Barrier NOTE3	MTL 7758+	MTL 7715P+	MTL 7715P+	MTL 7787P+	MTL 7787P+	MTL 7787+			

NOTE1 The ID5002P is supplied with a suitable internal switch.

NOTE2 The ID5002P is supplied with a suitable sensor.

NOTE3 Use only barriers or accessories supplied or approved by Online Electronics Ltd.