



TRAX

Intelligent Pipeline
Technology

EMTx40 Operating Manual

Electromagnetic Transmitter

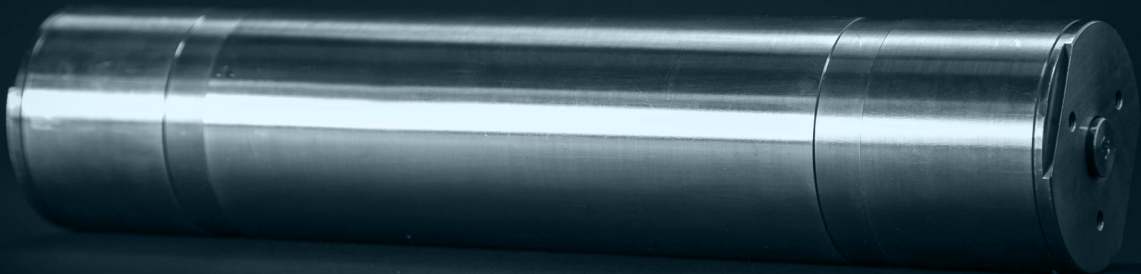

CONFIGURATION INFORMATION	
SERIAL NUMBER :	
PRODUCT CODE :	
FREQUENCY :	
PULSE LENGTH :	
REPETITION RATE :	
BATTERY LIFE AT +5°C :	

CONTENTS

Page

- 1. GENERAL DESCRIPTION 3
 - 1.1. ENDCAP OPTIONS 3
- 2. SPECIFICATIONS: 4
- 3. RULES FOR SAFE OPERATION 5
- 4. OPERATION 6
 - 4.1. TURNING ON 6
 - 4.2. TURNING OFF 6
 - 4.3. FUNCTION TEST 6
 - 4.4. CONFIGURATION..... 7
 - 4.4.1. EMTx CONFIG FOR WINDOWS 7
 - 4.4.2. EMTX CONFIG FOR ANDROID 10
 - 4.5. INSTALLATION 12
 - 4.6. DEPLOYMENT 13
- 5. MAINTENANCE 14
 - 5.1. BATTERY REPLACEMENT 14
 - 5.2. BATTERY LIFETIME 15
 - 5.3. O-RING REPLACEMENT 17
 - 5.3.1. BLEEDSCREW 17
 - 5.3.2. BATTERY / PCB ENDCAP 17
- 6. STORAGE 18
- 7. DISPOSAL OF UNIT 18
- 8. WARRANTY 19
- 9. SAFETY INSTRUCTIONS 19
- 10. DECLARATION OF CONFORMITY (EU) 20
- 11. DECLARATION OF CONFORMITY (UK) 21

Revision	Updated By	Description of Update	Update Date
A00	RJS	CR01099: Initial release.	09/10/24
A01	SS/RJS	Updated windows app screenshots and battery lifetime predictions	27/11/24

1. GENERAL DESCRIPTION

The EMTx40 EM Transmitter is an electromagnetic transmitter which can be used for pig tracking and locating functions. The transmitter operates effectively in buried pipelines, pipelines carrying gas or liquid and in pipeline bundles where acoustic transmitters are either less effective or ineffective.

The EMTx40 transmitter produces a strong signal which can be detected through even heavy pipeline walls. Using the IK Trax EMTx Config application (Windows or Android) the transmitter frequency, power and pulse pattern can be configured to optimise performance and battery life. Received signal strength is dependent on several factors including pipeline diameter, pipeline material, pig design, pig speed, transmitter configuration, receiver equipment and background electromagnetic noise levels. Please contact IK Trax to discuss the most effective transmitter configuration.

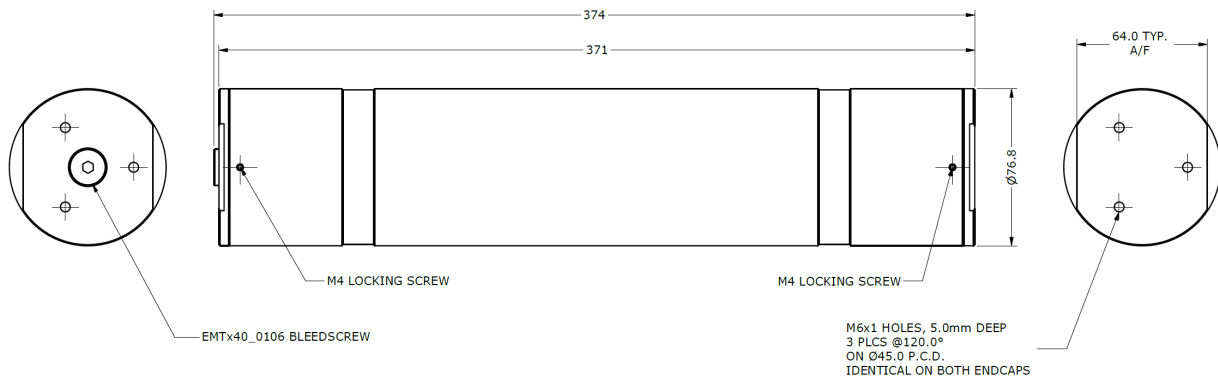

1.1. ENDCAP OPTIONS

All EMTx40 transmitters comes fitted with PCB and Battery Endcaps as standard. The Battery Endcap incorporates a Bleedscrew as standard.

2. SPECIFICATIONS:

NOTE THAT THE SPECIFICATIONS BELOW ARE VALID FOR THE STANDARD CONFIGURATION ONLY. REFER TO PAGE 1 OF THIS MANUAL FOR THE CONFIGURATION INFORMATION SPECIFIC TO THE TRANSMITTER BEING USED.

Battery Type.....	Alkaline D Cell Pack
Lifetime at 100% power, continuous mode, +5°C (+41°F)	2.7 days
Lifetime at 100% power, continuous mode, +20°C (+68°F)	3.4 days
Lifetime at 100% power, 0.4s ON / 2.6s OFF pulse rate, +5°C (+41°F)	15.7 days
Lifetime at 100% power, 0.4s ON / 2.6s OFF pulse rate, +20°C (+68°F).....	19.6 days
Lifetime in other configurations	See 5.2 BATTERY LIFETIME
Frequency	adjustable 10Hz to 30Hz in 0.1Hz increments
Power.....	adjustable 10% to 100% in 10% increments
Pulse length	adjustable 0.3 second to 1.0 second in 0.1 second increments
Pulse rate	adjustable 1 second to 10 seconds in 1 second increments
Temperature range (alkaline).....	-20°C to + 50°C (-4°F to + 122°F)
Temperature range (lithium).....	-40°C to + 80°C (-40°F to + 176°F)
Bump rating	20G
Housing material.....	ASTM B348 Grade 5 Titanium Ti-6Al-4V
Endcap material	Alloy Bronze CA 104 EN 12163
O-ring material	NBR70
Transmitter weight in (including batteries)	7kg (15.5lbs)
Length	374mm (14.7")
Diameter	76.8mm (3.02")
External pressure rating	500bar (7252psi)
ATEX/IECEX/UKEx code	Ex db IIb+H2 T6..T5 Gb
EU Type Examination Certificate Number	ERO23ATEX0011X
UK Type Examination Certificate Number	EMA23UKEX0026X
IECEX Certificate Number	IECEX EMT 23.0008X

3. RULES FOR SAFE OPERATION

⚠ WARNING: The Special Conditions for Safe Use as detailed in section 9 must be followed at all times.

⚠ WARNING: Any operation involving pressure is potentially hazardous. No person should use this equipment unless they are fully aware of the potential hazards of working with pressurised vessels. The purchaser of this equipment is responsible for the training and competence of operators and the manner in which it is used. This manual should be read through and understood before installation and commissioning so that the operator is familiar with the equipment. Contact IK Trax immediately should any difficulty arise in the use of this equipment.

⚠ WARNING: DO NOT open when an explosive atmosphere may be present. Always use caution when opening equipment which has been in a pressurised environment. It is possible for pressure to leak into the equipment and remain there even after external pressure has been removed. ALWAYS point the end to be opened towards a safe area and away from yourself or others. Contact IK Trax immediately if there is a suspicion that the equipment has become pressurised.

⚠ WARNING: USE ONLY approved D Cell batteries. ALWAYS observe correct battery polarity. New batteries should be installed before each deployment.

⚠ WARNING: Do not expose to aggressive solvents or chemicals which could be harmful to the HOUSING, O-RINGS, CONNECTORS or any other parts of the equipment.

⚠ CAUTION: This equipment should only be opened in a clean laboratory environment.

⚠ CAUTION: To prevent the formation of condensation within the transmitter, allow the transmitter temperature to stabilise within the laboratory environment for a minimum of 6 hours prior to opening.

⚠ CAUTION: It is possible for liquids to become trapped in threads and/or gaps around openings. ALWAYS point the end to be opened downwards to allow any trapped liquid to drain out of and not into the equipment.

4. OPERATION

The following instructions are for a unit fitted with the standard Battery Endcap and PCB Endcap.

1. Familiarise yourself with all the rules for the safe operation of this equipment as described in Section 3 RULES FOR SAFE OPERATION.

4.1. TURNING ON

1. To turn the transmitter on, use an A/F 5MM Allen key to insert the Bleedscrew flush to the Battery Endcap, do not use excessive torque. If the transmitter has been shipped with an insulating washer between the endcap and the bleedscrew, remove the bleedscrew fully first to free the washer and then insert. Note that very little torque is required. Damage may occur if over tightened. The transmitter takes approximately 15 seconds to turn on.
2. Use an EM receiver such as the IK Trax EMRxEEx to confirm that the transmitter has turned on.

4.2. TURNING OFF

1. To turn the transmitter off, use an A/F 5MM Allen key to remove the Bleedscrew to the Battery Endcap. The transmitter should turn off immediately. Replace the insulating washer and insert the Bleedscrew for safe storage.
2. Use an EM receiver such as the IK Trax EMRxEEx to confirm that the transmitter has turned off.

4.3. FUNCTION TEST

An EM receiver, such as an IT Trax EMRxEEx Receiver is required to receive the signal from the transmitter. Refer to the relevant EM receiver manual for instruction on setup and operation of the EM receiver.

1. Place the EM receiver antenna approximately 4m away and parallel to the transmitter.
2. Activate the transmitter as detailed in Section 4.1 TURNING ON.
3. Confirm that a clear signal is received, and the pulse rate is as expected.
4. Switch the transmitter between OFF and ON a few times to ensure that the signal received reacts as expected.
5. An inherent null spot is detectable when the antenna is at 90 degrees to and pointing towards the centre of the transmitter allowing accurate positioning of a pig. Refer to the relevant EM receiver manual for further information.
6. Turn OFF the transmitter as detailed in Section 4.2 TURNING OFF.
7. If all results were as expected, then the system is functional.

4.4. CONFIGURATION

An EM Transmitter has configurable parameters that can be changed via a Bluetooth connection using either the EMTx CONFIG for Windows app or the EMTx CONFIG for Android app. Ensure that the laptop/desktop computer or Android mobile phone/tablet has Bluetooth turned on and that all devices are discoverable. If the laptop/desktop does not have built in Bluetooth, a USB Bluetooth dongle can be used; see the EMTx CONIG manual for more details. The following section assume built in Bluetooth in Windows 10 (or 11).

4.4.1. EMTX CONFIG FOR WINDOWS

1. Follow the instructions contained in the EMTx CONFIG for Windows User Manual.
2. Install the latest version of EMTx CONFIG for Windows via the IKTrax website.
3. Run the application. The Configure Tab will be highlighted by default as will Windows 10 Bluetooth connection method. Bluetooth will scan for EMTx devices as shown below.

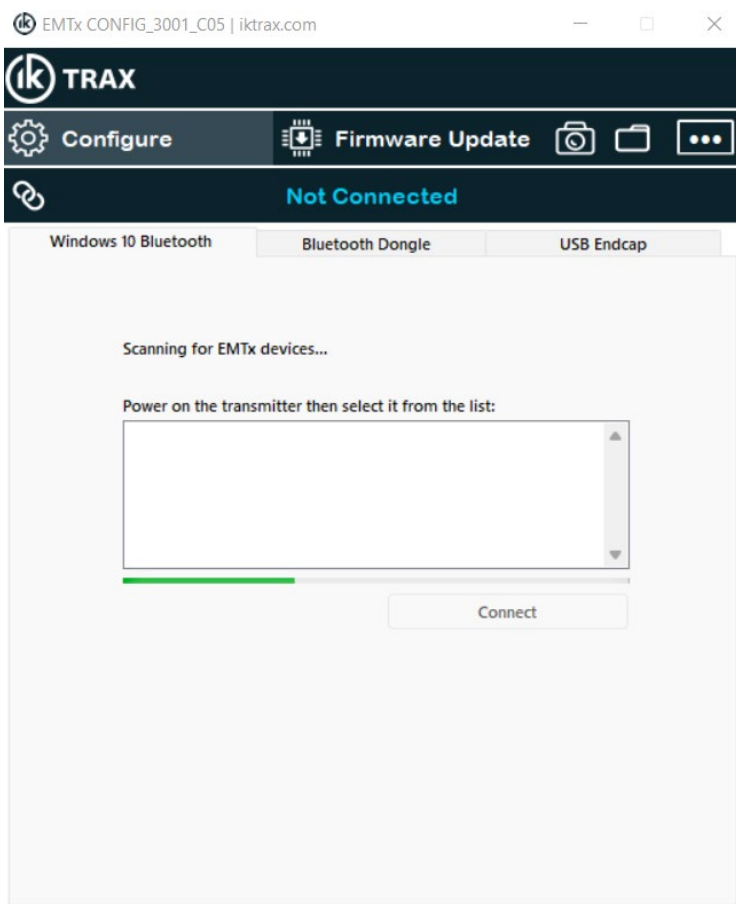

4. The transmitter, when turned on, will be discoverable on Bluetooth for 15 seconds. During this time 'Connect' to the EMTx40 as shown below:

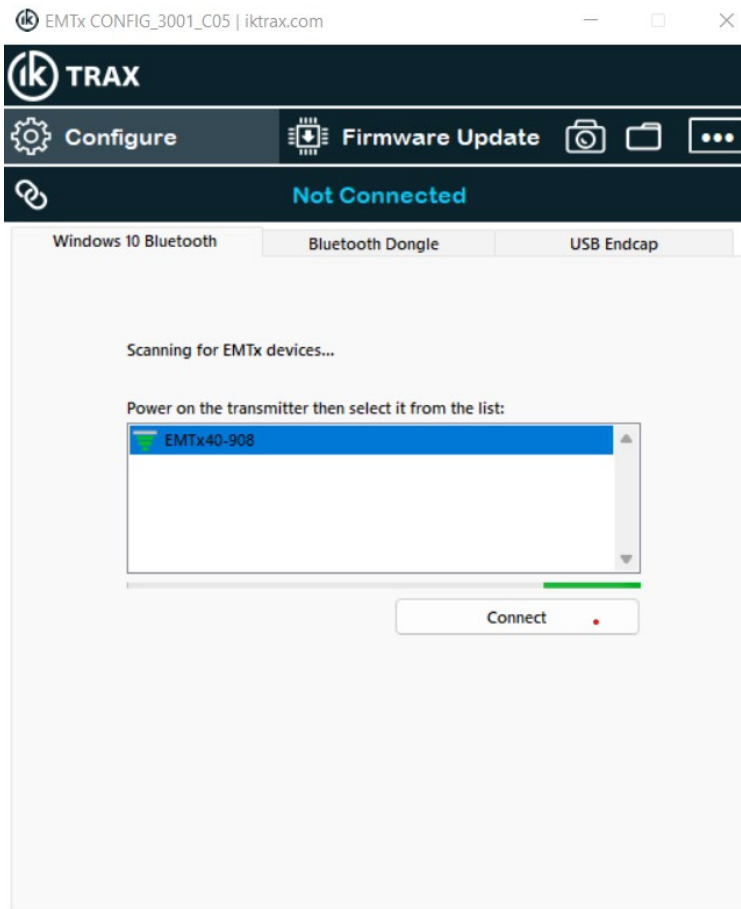

5. Once connected, the following parameters can be configured:

- Power Setting
- Pulse Rate
- Pulse Length
- Start Delay
- Frequency

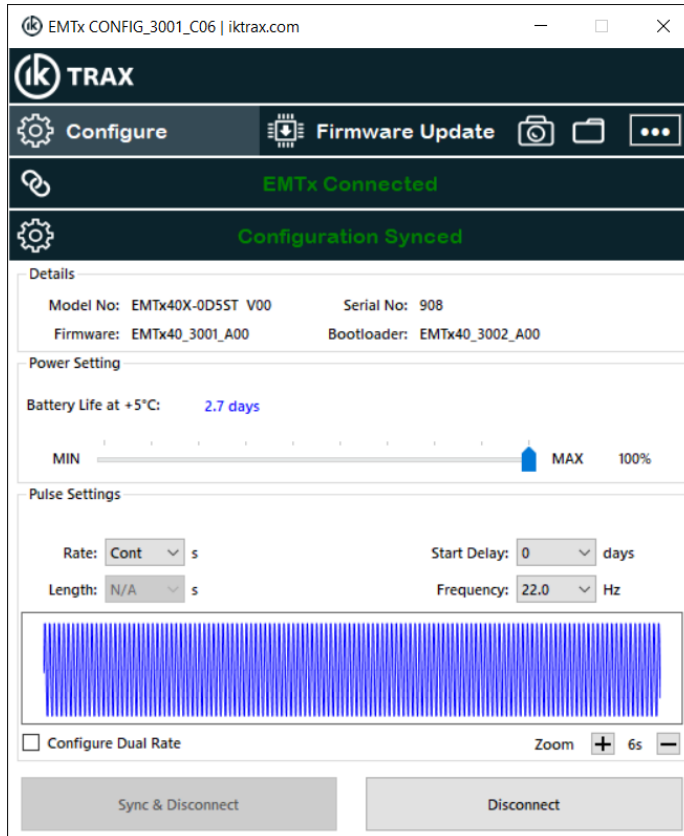

6. Once the changes required have been made, select 'Sync and Disconnect' for the changes to take effect. The transmitter will start to run with the new parameters. To discard all changes select 'Disconnect'. The transmitter will start running with the previous configured settings.

4.4.2 EMTX CONFIG FOR ANDROID

1. Follow the instructions in the EMTx CONFIG for ANDROID User Manual.
2. Download and install the latest version of EMTx CONFIG for ANDROID from the Google Play Store.
3. Run the application.

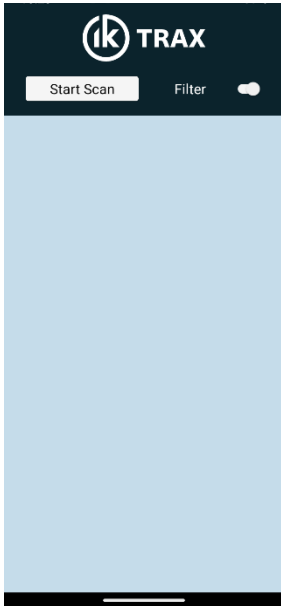

4. Click on 'Start Scan'.
5. The transmitter, when turned on, will be discoverable on Bluetooth for 15 seconds. During this time 'Connect' to the EMTx40.

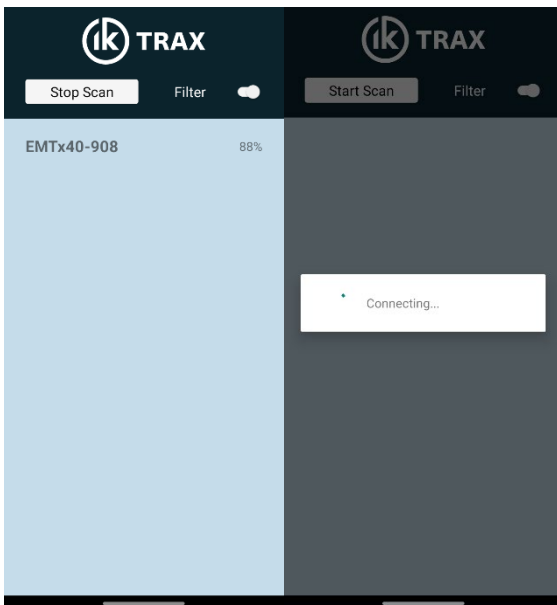

6. Once connected, the following parameters can be configured:

Transmit Frequency
Transmit Rate
Power
Activation Delay

(depending on screen size/orientation, the user may have to scroll to see all configurable parameters).

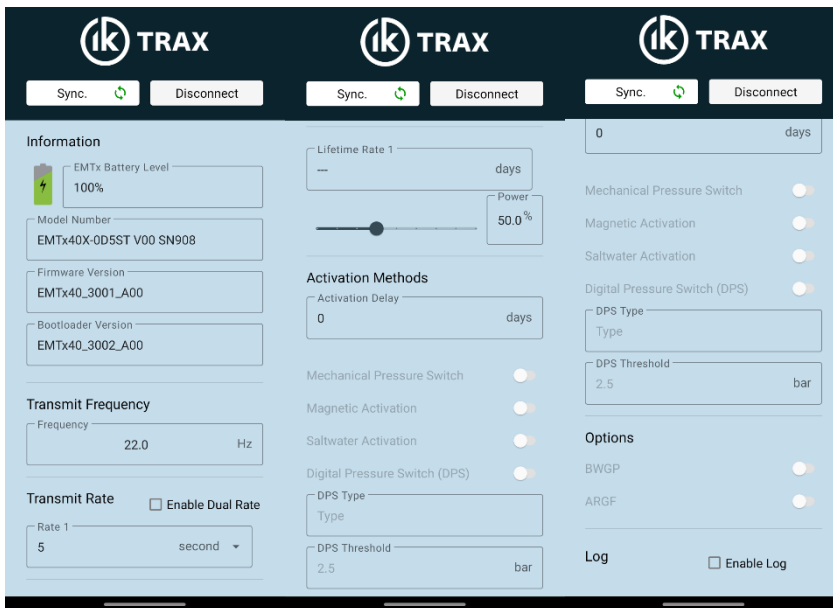

- Once the changes required have been made, select 'Sync' and then 'Disconnect' for the changes to take effect. To discard any changes simply select 'Disconnect'.

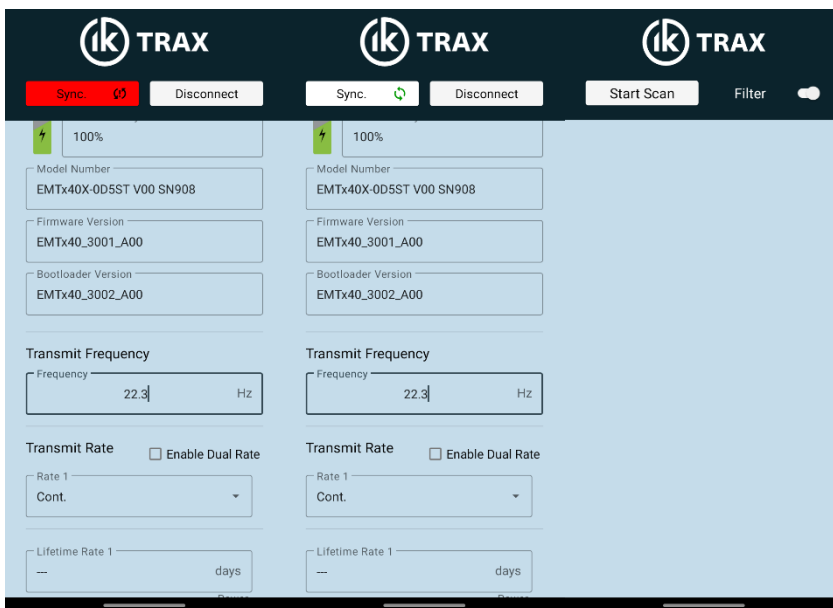

4.5. INSTALLATION

⚠ WARNING: The Special Conditions for Safe Use as detailed in SECTION 9 must be always followed.

⚠ WARNING: The transmitter must be mounted in such a way that no movement or vibration is possible whatsoever (e.g. clamped). If the transmitter is allowed to rattle and/or vibrate within the pig then the resultant hammering effect can exceed the bump rating of the transmitter leading to damage and/or failure. This is particularly important in gas pipelines.

⚠ CAUTION: All EM transmitters will induce electrical currents in any conductive materials closely surrounding them which can result in a severe reduction in signal strength and/or battery lifetime. This effect can be minimised by reducing the amount of conducting material surrounding the transmitter and leaving as much of the transmitter exposed as possible. Any slits or apertures which can be made in the surrounding material will help. Use materials with as high resistance as possible. Non-conducting materials such as plastics will not suffer from this effect. EM transmitters must not be surrounded by low resistance metals such as aluminium (including tubes or mounting clamps) under any circumstances.

⚠ CAUTION: Any magnetic material surrounding the transmitter will tend to block the EM signal from the transmitter and reduce the received signal strength outside the pipeline. This effect can be minimised by reducing the amount of magnetic material surrounding the transmitter and leaving as much of the transmitter exposed as possible. Any slits or apertures which can be made in the surrounding material will help. Use materials with as low magnetic permeability as possible. Non-magnetic materials such as plastics will not suffer from this effect. The table below shows the typical characteristics of several potential pig and mounting materials with the best choice at the top, and the worst choice at the bottom. 316 stainless steel provides a good balance of properties and cost. An aluminium alloy would be a very poor choice because of the very low resistivity and should not be used under any circumstances.

MATERIAL	RESISTIVITY ($\mu\Omega.m$)	MAGNETIC PERMEABILITY
PLASTIC	∞	1.000
316 STAINLESS STEEL	0.75	1.008
2205 DUPLEX SS	0.80	>25.0
1005 STEEL	0.20	>100
ALUMINIUM ALLOYS	0.04	1.000

For optimum performance the transmitter should be clamped inside a plastic pig body. A alternative mounting arrangement is shown below. It uses several lengths of threaded studding to clamp the transmitter between two plates. The advantage of this arrangement is that it has limited amounts of metal around the transmitter and will therefore have limited effect on the transmitter performance. Please contact IKTRAX for further information and guidelines regarding EM transmitter mounting and installation.

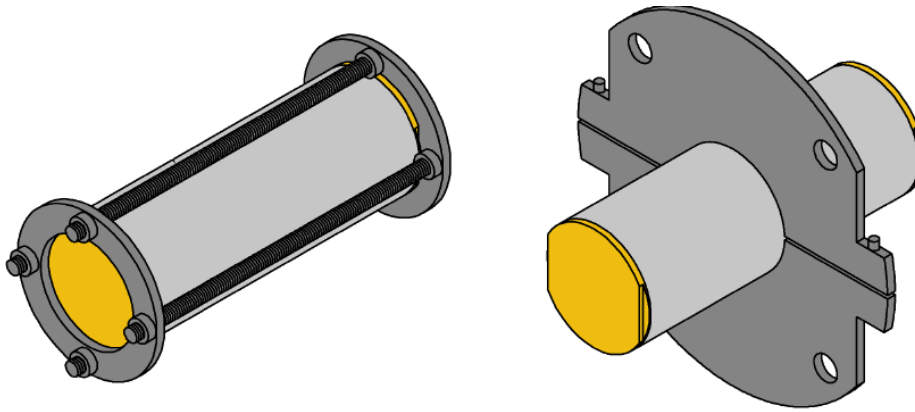

⚠ CAUTION: In extreme circumstances strong magnets in close proximity to EM transmitters may dramatically impact signal and lifetime. Where possible maintain a separation of at least 200mm between the EM transmitter and any magnets.

4.6. DEPLOYMENT

Before each deployment ensure that the following checks have been completed.

1. Ensure that the transmitter has been installed as detailed in Section 4.5 INSTALLATION.
2. Visually inspect all system components to ensure that they are secure and undamaged.
3. Refer to Page 1 of this manual for the expected battery lifetime and ensure that it is adequate for the planned operations.
4. Activate the transmitter as detailed in Section 4.1 TURNING ON.
5. Complete a Section 4.33 FUNCTION TEST.

5. MAINTENANCE

Familiarise yourself with all of the rules for the safe operation of this equipment as described in Section 3 RULES FOR SAFE OPERATION.

The EMTx40 EM transmitters are designed to require minimum maintenance. The transmitter should be cleaned using fresh water and cleaning agents as necessary (e.g. WD40). Do not use chemicals which could be damaging to the housing or O-rings.

Check flame paths / threads on the housing body and endcaps for signs of corrosion or damage. If badly pitted or damaged, consult IK Trax for advice on replacing the relevant part.

All parts which are replaced must be in accordance with the manufacturers' specifications. Failure to use such components may invalidate the certification/approval and may make the equipment dangerous.

IK Trax can supply redress kits containing a complete set of replacement batteries, O-rings, O-ring grease and thread lubricant, contact IK Trax for more information.

5.1. BATTERY REPLACEMENT

1. Familiarise yourself with all warnings given at the start of Section 3 RULES FOR SAFE OPERATION. Refer to below diagram outlining all parts involved for battery replacement.

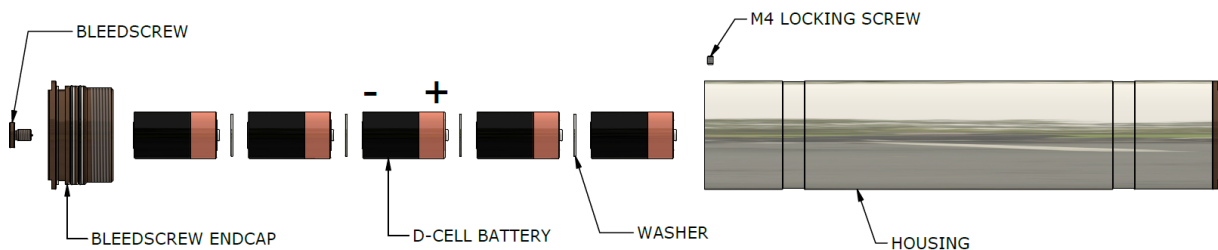

2. Remove the BLEEDSCREW from Battery ENDCAP using an A/F 5MM Allen key to turn off transmitter. Be cautious of potential trapped pressure in the enclosure and adhere to instructions given in Section 3 on how to safely remove the BLEEDSCREW.
3. Release BATTERY ENDCAP from the HOUSING by removing grub screw using an A/F 2MM Allen key. Then using the endcap removal tool supplied, slowly unscrew the BATTERY ENDCAP from the housing.
4. Examine the O-ring seals for any signs of contamination or damage, replace and/or re-grease if necessary. Refer to Section 5.3 O-RING REPLACEMENT for guidance.
5. Remove the D-CELL batteries from the transmitter by tilting the transmitter such that the D-CELL batteries slide out, preferably onto a surface such as a desk or workbench. Be careful not to drop the D-CELL batteries such that they could injure you. Retain the washers that are placed between the D-CELLS.
6. Observing correct D-CELL battery orientation as shown above (positive pip facing into the transmitter) insert new D-CELL battery into the transmitter followed by a washer. Repeat with three more D-CELL batteries and washers. Finally insert the final D-CELL battery.

7. Once D CELL batteries have been inserted, ensure when looking into the open end of the transmitter that the negative end of the final battery is facing you.
8. Examine the O-ring seal on the transmitter for any signs of contamination or damage, replace and/or re-grease if necessary. Refer to Section 5.3 O-RING REPLACEMENT for guidance.
9. Secure the BATTERY ENDCAP to the transmitter with the endcap removal tool and reinsert the grubscrew.
10. Examine the O-ring seal on the BLEEDSCREW for any signs of contamination or damage, replace and/or re-grease if necessary. Refer to Section 5.3 O-RING REPLACEMENT for guidance.
11. Install BLEEDSCREW into Battery ENDCAP partially to secure the BLEEDSCREW. Make up the BLEEDSCREW fully if the transmitter is to be switched on. Refer to section 4.1 for switching the unit on.

5.2. BATTERY LIFETIME

The operating temperature at which the transmitter is used alters the operating lifetime with colder temperatures typically shortening achievable lifetime.

Transmitter frequency effects lifetime because pulse lengths are restricted to a whole number of cycles of the transmitter frequency. The lifetimes stated in this manual are all at 22.0Hz unless stated otherwise and will not vary by more than 10% at other frequencies. The EMTx Config Windows and Android applications include the effects of frequency in their lifetime predictions.

In extreme circumstances the transmitter operating lifetime may be reduced by how the transmitter is installed on a pig. Refer to section 4.5 INSTALLATION within this manual for tips on how to achieve optimum performance from the transmitter with regards to the mounting arrangement.

The tables below show predicted lifetimes for a range of configurations. The mVpp values show the predicted signal received in open air at 1m with IK Trax reference antenna.

Please contact IK Trax to discuss any project specific requirements.

EMTx40 predicted lifetimes (days), 0.4s pulse length, +5°C - ALKALINE						
Power Setting	Cont.	1 sec	2 sec	3 sec	4 sec	5 sec
100% (650mVpp)	2.7	6	11.1	15.7	19.9	23.5
50% (433mVpp)	5.4	12	22.2	31.5	39.8	47
20% (260mVpp)	13.5	30	55.6	78.7	99.4	117.6

EMTx40 predicted lifetimes (days), 0.4s pulse length, +20°C - ALKALINE						
Power Setting	Cont.	1 sec	2 sec	3 sec	4 sec	5 sec
100% (650mVpp)	3.4	7.5	13.9	19.6	24.9	29.4
50% (433mVpp)	6.8	15	27.8	39.4	49.8	58.8
20% (260mVpp)	16.9	37.5	69.5	98.4	124.3	147

EMTx40 predicted lifetimes (days), 0.4s pulse length, +5°C - LITHIUM						
Power Setting	Cont.	1 sec	2 sec	3 sec	4 sec	5 sec
100% (650mVpp)	4	9	16.7	23.6	29.9	35.3
50% (433mVpp)	8	18	33.3	47.3	59.7	70.5
20% (260mVpp)	20	45	83.4	118	149.1	176.4

EMTx40 predicted lifetimes (days), 0.4s pulse length, +20°C						
Power Setting	Cont.	1 sec	2 sec	3 sec	4 sec	5 sec
100% (650mVpp)	5	11.3	20.9	29.5	37.4	44.1
50% (433mVpp)	10	22.5	41.6	59.1	74.6	88.1
20% (260mVpp)	25	56.3	104.3	147.5	186.4	220.5

5.3. O-RING REPLACEMENT

5.3.1. BLEEDSCREW

1. Using an A/F 5MM Allen key, remove the BLEEDSCREW from the Battery ENDCAP.
2. Referring to the figure below, remove all O-rings and clean all sealing surfaces on all parts.

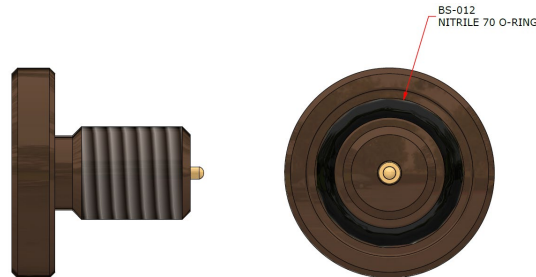

3. Examine all surfaces for signs of corrosion, scoring, and other damage. If there is excessive damage the mechanical parts may need to be replaced.
4. Lightly grease all sealing surfaces using a suitable grease (e.g. DOW CORNING MOLYKOTE 111 COMPOUND).
5. Lightly grease each O-ring with a suitable grease (e.g. DOW CORNING MOLYKOTE 111 COMPOUND) before fitting.
6. Apply a small amount of an oil-based thread lubricant such as "Blue Goop" to the BLEEDSCREW threads. Refer to section 5.1 Step 13 for instruction on installing the BLEEDSCREW.

5.3.2. BATTERY / PCB ENDCAP

1. Release the BATTERY / PCB ENDCAP from HOUSING by removing grubscrew using an A/F 2MM Allen key.
2. Remove the BATTERY / PCB ENDCAP by unscrewing from the HOUSING using the ENDCAP removal tool.
3. Referring to the figure below, remove O-rings and Back-up Rings and clean all sealing surfaces on all parts.

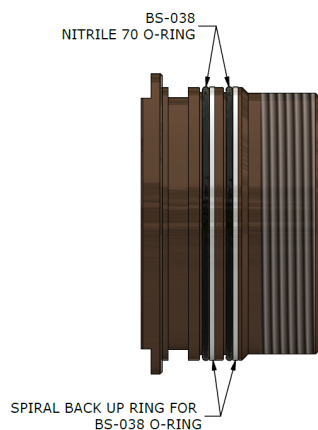

4. Examine all surfaces for signs of corrosion, scoring, and other damage. If there is excessive damage the mechanical parts may need to be replaced.
5. Lightly grease all sealing surfaces using a suitable grease (e.g. DOW CORNING MOLYKOTE 111 COMPOUND).
6. Lightly grease each O-ring and Back-up Ring with a suitable grease (e.g. DOW CORNING MOLYKOTE 111 COMPOUND) before fitting in the groove in the BATTERY / PCB ENDCAP.
7. Ensure the free space at the tails of the spiral Back-up Rings are filled with grease and then apply a layer of grease over the seams to secure them in place. The spiral tails should not protrude from the assembly.
8. Fit the BATTERY / PCB ENDCAP using the endcap removal tool. Secure with the grub screw. Refer to section 5.1 Step 13 for instruction on installing the BLEEDSCREW.

6. STORAGE

Familiarise yourself with all of the rules for the safe operation of this equipment as described in Section 3 RULES FOR SAFE OPERATION.

If the transmitter is to be placed in storage for a long period of time remove the batteries from the transmitter and store separately.

As a minimum the BLEEDSCREW must be loosened 3 full turns to switch the transmitter off.

7. DISPOSAL OF UNIT

IK Trax takes its responsibilities under the WEEE Regulations extremely seriously and has taken steps to be compliant in line with our corporate and social responsibilities. In the UK, IK Trax has joined a registered compliance scheme WeeeCare (registration number **WEE/MP3538PZ/SCH**).

Electrical and electronic equipment should never be disposed of with general waste but must be separately collected for the proper treatment and recovery.

The crossed-out bin symbol, placed on the product, reminds you of the need to dispose of it correctly at the end of its life.

When buying a new product, you will have the possibility to return, free of charge, another end-of-life product of equivalent type that has fulfilled the same functions as the supplied equipment. These items may be deposited at:

Online Electronics Ltd
Doing business as IK Trax
Blackburn Business Park
Woodburn Road
Blackburn
Aberdeen
AB21 0PS
UK

Alternatively, to arrange a collection of any waste electrical equipment, obligated to IK Trax please telephone WeeeCare on **0844 800 2004**.

8. WARRANTY

IK Trax products are guaranteed for one year from the date of purchase. Goods should be returned transportation prepaid to IK Trax.

There is no charge for parts or labour should any product require repair due to a manufacturing deficiency during the guarantee period.

In the event of a manufacturing deficiency the inward transportation costs will be repaid to the client.

9. SAFETY INSTRUCTIONS

SPECIAL CONDITIONS FOR SAFE USE:

1. Only use one complete set of new and identical cells.
2. Only the following permitted batteries shall be used with the corresponding ambient temperature and temperature class.

CELL MANUFACTURER & PART NUMBER	CELL TYPE	CELL VOLTAGE	OPERATING AMBIENT TEMPERATURE	TEMPERATURE CLASS
PROCELL CONSTANT PC1300 (LR20)	Alkaline	1.5V	-20°C to +54°C	T6
ENERGIZER E95	Alkaline	1.5V	-18°C to +55°C	T6
SAFT LS 33600	Lithium	3.6V	-40°C to +80°C	T5

3. The batteries must be installed into the enclosure in accordance with the orientation detailed on the markings. Refer to section 5.1.
4. Repair of flame paths is not permitted by the end user.
5. Do not open when an explosive atmosphere may be present.
6. Units must be installed such that ignition sources due to impact and friction sparks are excluded.
7. When required, thread lubricant / grease to be applied to all threads except those of the M4 locking screws. The lubricant / grease shall be of a type that does not harden because of ageing, does not contain an evaporating solvent, and does not cause corrosion of the joint's surfaces, such as Bostik Blue Goop or equivalent.
8. Where used, the bleed screw must be tightened to a torque between 4Nm and 8Nm. Do not exceed 8Nm.

10. DECLARATION OF CONFORMITY (EU)

This declaration of conformity is issued under the sole responsibility of the manufacturer:

Online Electronics Ltd
Online House
Blackburn Business Park
Woodburn Road
Blackburn
Aberdeen
AB21 0PS
UNITED KINGDOM

Object of declaration:

EMTx_40X range of electromagnetic transmitters

With the following markings:



II 2 G Ex db IIB+H₂ T6...T5 Gb

The object of the declaration described above is in conformity with the relevant Union harmonization legislation:

ATEX: ATEX Directive 2014/34/EU
EMC: EMC Directive 2014/30/EU

The following standard(s) and technical specification(s) have been applied:

ATEX: EN IEC 60079-0:2018
EN 60079-1:2014

UKEx: EN IEC 60079-0:2018
EN 60079-1:2014

IECEX: IEC 60079-0:2017
IEC 60079-1:2014

EMC: EN61000-6-4:2007
EN61000-6-2:2005

As per the certificate(s) below:

ATEX: EU Type Examination Certificate ERO23ATEX0011X issued by Element Rotterdam BV, Notified Body 2812, under GB/TRC/QAR11.0002/10. Refer to Special Conditions of Safe Use within ERO23ATEX0011X.

UKEx: UK Type Examination Certificate EMA23UKEX0026X issued by Element Skelmersdale UK, Approved Body 0891, under EMA21UKQAN0017 R04. Refer to Special Conditions of Safe Use within EMA23UKEX0026X.

IECEX: IECEX Certificate of Conformity IECEX EMT 23.0008X issued by Element Materials Technology under GB/TRC/QAR11.0002/10. Refer to Conditions of Certification within IECEX EMT 23.0008X.

The apparatus named above has been designed to comply with the relevant sections of the above referenced specifications and complies with all essential requirements of the Directives and Systems.

11. DECLARATION OF CONFORMITY (UK)

This declaration of conformity is issued under the sole responsibility of the manufacturer:

Online Electronics Ltd
Online House
Blackburn Business Park
Woodburn Road
Blackburn
Aberdeen
AB21 0PS
UNITED KINGDOM

Object of declaration:

EMTx_40X range of electromagnetic transmitters

With the following markings:

 II 2 G Ex db IIB+H₂T6...T5 Gb

The object of the declaration described above is in conformity with the relevant Union harmonization legislation:

UKEx: Equipment and Protective Systems Intended for Use in Potentially Explosive Atmospheres UKSI 2016:1107
EMC: EMC Directive 2014/30/EU

The following standard(s) and technical specification(s) have been applied:

ATEX: EN IEC 60079-0:2018
EN 60079-1:2014
UKEx: EN IEC 60079-0:2018
EN 60079-1:2014
IECEX: IEC 60079-0:2017
IEC 60079-1:2014
EMC: EN61000-6-4:2007
EN61000-6-2:2005

As per the certificate(s) below:

ATEX: EU Type Examination Certificate ERO23ATEX0011X issued by Element Rotterdam BV, Notified Body 2812, under GB/TRC/QAR11.0002/10. Refer to Special Conditions of Safe Use within ERO23ATEX0011X.
UKEx: UK Type Examination Certificate EMA23UKEX0026X issued by Element Skelmersdale UK, Approved Body 0891, under EMA21UKQAN0017 R04. Refer to Special Conditions of Safe Use within EMA23UKEX0026X.
IECEX: IECEX Certificate of Conformity IECEX EMT 23.0008X issued by Element Materials Technology under GB/TRC/QAR11.0002/10. Refer to Conditions of Certification within IECEX EMT 23.0008X.

The apparatus named above has been designed to comply with the relevant sections of the above referenced specifications and complies with all essential requirements of the Directives and Systems.