



**TRAX**

Intelligent Pipeline  
Technology

Pre-Commissioning  
Assurance  
Products & Services



# About

---

With over 25 years of expertise and a successful history, IK Trax have a proven track record in designing and manufacturing pipeline pig locating and signalling equipment, as well as advanced pipeline data logging and testing systems, guaranteeing our clients total assurance in their operations.

Efficiently transitioning from cleaning and gauging to hydrotesting and dewatering during pipeline pre-commissioning is crucial for minimising costs and keeping projects on schedule.

Accurate pig tracking and locating is essential for ensuring smooth and efficient pigging operations, particularly in subsea pipelines. Without it, locating a stalled pig can be time-consuming, leading to unplanned downtime and increased project costs. It can also provide operational confidence by quickly confirming that a pig has reached its expected location, such as the pig receiver.

Alongside pig tracking and signalling, our data logging and testing solutions play a crucial role in streamlining the pipeline pre-commissioning process. They provide live data, assuring operators that they can proceed to the next stage. These solutions include pipeline gauging data systems, monitoring of key parameters during the hydrotest and pipeline conditioning assurance in real-time.

By integrating pig locating, signalling and pipeline data logging systems, IK Trax offers a comprehensive solution that significantly enhances the efficiency and accuracy of pipeline pre-commissioning operations. Our solutions are designed to meet the unique challenges of the pipeline industry, ensuring that your projects are completed on time, within budget and with the highest level of assurance.

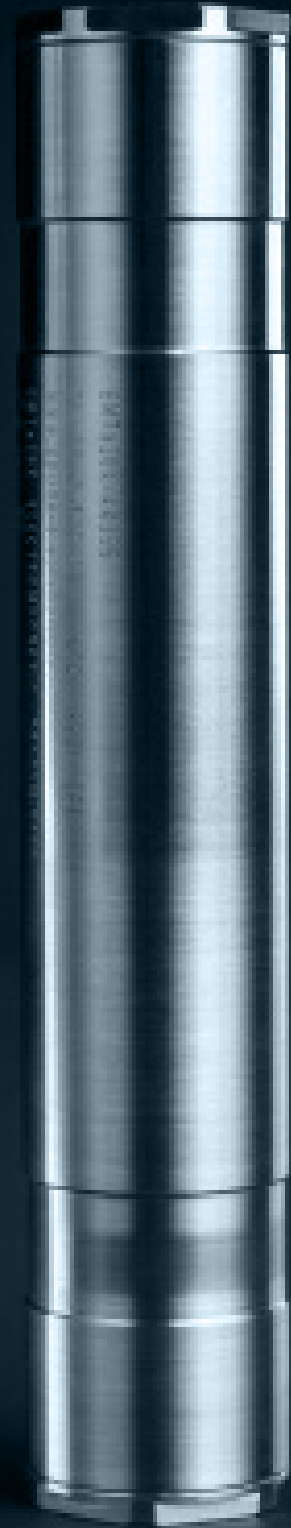

Intelligent Pipeline  
Technology

## Magnetic Non-Intrusive Signallers

Magnetic Non-Intrusive Signallers confirm the successful launch and receipt of magnetic pigs and confirm pig passage at critical points along the pipeline. They can be installed quickly and easily to the pipeline and require minimal setup. All signallers provide local indication of pig passage via a graphical display and high-brightness LEDs. Magnetic signallers can be installed on pipelines of any size and carrying any medium.



### Designed for Temporary Installation

#### 4001D MAGSIG® TOPSIDE

The 4001D MAGSIG® is ATEX and IECEx certified meaning it can be installed in hazardous areas, for example on platforms. The 4001D is a user-friendly device with an intuitive display that communicates pig passage data. The user can easily navigate and control the unit directly from the display.

#### 4000SD SUBSEA

The 4000SD is a compact, self-contained, magnetic pig signaller which is suitable for harsh subsea applications and has an operating depth of 3,000m. The 4000SD can be deployed by a diver or an ROV and remote signalling can be provided with the addition of an Acoustic Link or Strobe.

#### Features and benefits:

- Up to 99 logged events
- Graphical display and high-brightness LED
- Events can be viewed locally and reviewed later via the display
- Single control button and intuitive menu system
- Quick and easy setup
- Versatile

### Designed for Permanent Installation

#### 4004S SUBSEA

Unlike traditional subsea signallers, the 4004S is designed for permanent installation on subsea pipelines and can be externally powered through a subsea cable connected to a topside control system. The 4004S can be easily installed and removed by divers with a bespoke clamp system. All metal components, including the clamp assembly, are made from super duplex stainless steel – highly resistant to corrosion in subsea environments – ensuring durability and reliability for long-term operation.

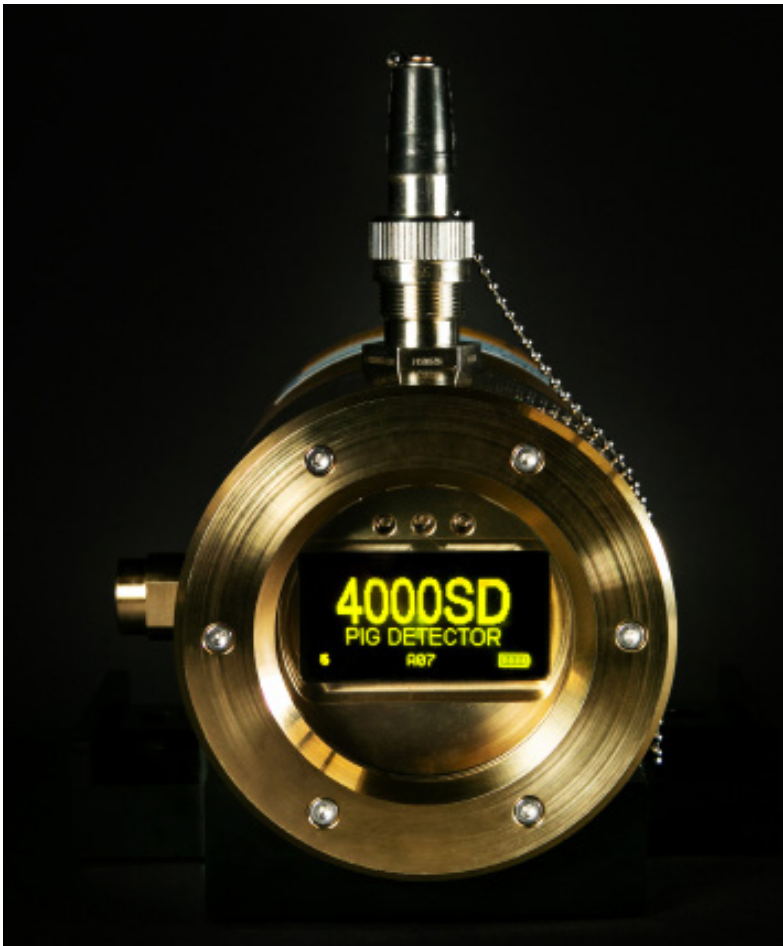



## Electromagnetic Pig Locating

Electromagnetic transmitter and receiver systems enable quick and accurate locating of a pipeline pig in a topside or subsea pipeline carrying any medium. They can also be used as a contingency method of confirming launch and receipt. Electromagnetic technology is suitable not only for standard unburied pipelines but also for buried or trenched pipelines, pipeline bundles, and pipe-in-pipe systems.

### Electromagnetic Transmitters

Pipeline pigs can be fitted with electromagnetic transmitters, enabling accurate verification of their location. IK Trax provides a wide range of ATEX and IECEx-certified transmitters to suit all pipeline sizes.

An electromagnetic transmitter can be located to within a few centimetres. This reduces vessel and operational downtime by facilitating the process of locating a stalled pig or confirming if a pig has left the launcher or been successfully received.

Battery life can be conserved by using a Pressure Switch, Water or Magnetic Activation Endcap. This means that pigs can be loaded in advance of the pig run without depleting battery life.



### Electromagnetic Config App

Our IK Trax Config Bluetooth and Windows Apps allow parameters such as frequency and pulse rate to be modified on-site to suit your project requirements. The app will also provide an estimated battery life under ambient temperature conditions based on your selected pulse rates and transmit power level. This enables you to configure these parameters to achieve the optimal balance between power and battery life.

# Electromagnetic Receivers

IK Trax's EMRx Multi-Frequency Receivers are used to locate and track pigs fitted with electromagnetic transmitters and/or magnets. They are designed for simple operation with one control carrying out all functions.

Both Onshore and Subsea options are offered, along with an ATEX and IECEx Zone 0 certified Receiver. The EMRx Subsea includes the option to relay the received signal back to the surface via ROV umbilical using RS485 allowing it to be interpreted topside.

EMRx Receivers permit the locating of transmitters even within very heavy walled launchers and receivers, pipeline bundles or Pipe-in-Pipe.

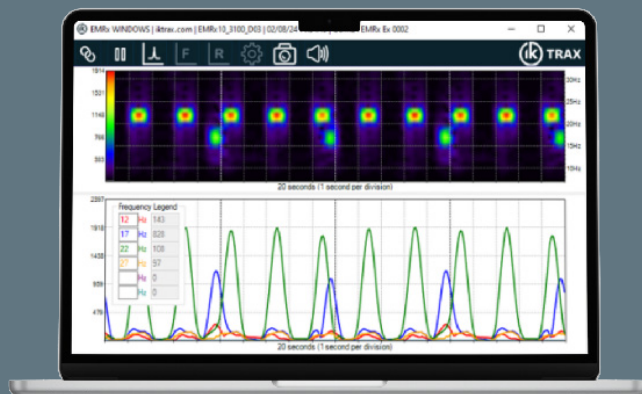

## Electromagnetic Receiver Applications

IK Trax's user-friendly EMRx Applications can be used in conjunction with any EMRx Receiver. They provide a graphical display of the signal, facilitating the pig locating and tracking process. They also allow advanced functionality such as tracking six colour-coded frequencies, audio output, data logging and the ability to mark points of interest. Screenshots and export functions allow for further analysis, reporting or sharing.

### Features and benefits

- EM transmitters have a detectable null spot, providing precise detection
- Full range of units to fit all pipeline sizes
- Self-regulation ensures the transmitter signal strength is constant over the battery lifetime
- Several advantages over Radioactive Isotopes:
  - Significantly less expensive than using Radioactive Isotopes
  - ATEX certification eliminates the need for special permits
  - No shipping restrictions associated with hazardous radioactive materials
  - Does not require specialised operators or equipment, making deployment simpler and more efficient
- Transmitter and receiver parameters can be modified by the user without the need to return to the manufacturer
- Titanium transmitter housings designed for high-pressure applications are available

## Datalogging & Testing

IK Trax's data logging and testing equipment remotely records and communicates data at different phases of the pipeline pre-commissioning process. This allows the support vessel to be available for other tasks.

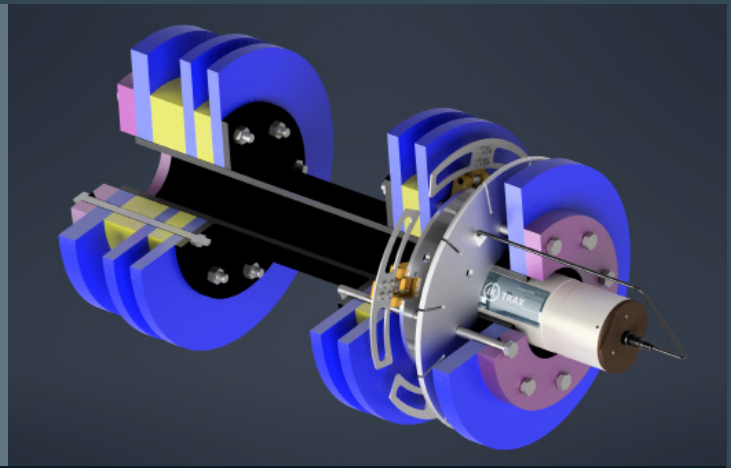

### Gauging Run Integrity Data (GRID®)

The GRID® system offers a cost-effective solution for identifying the presence of defects in subsea pipelines. This eliminates the need for pig recovery after a successful gauging run.

A pig fitted with a GRID® transmitter and gauge plate is run through the line. The transmitter monitors the condition of the gauge plate and reports status remotely via a Pass or Fail pulse rate.

#### Single-Hit System

The single-hit GRID® system features a standard gauge plate and reports the status of the first event.

#### Multi-Hit System

The multi-hit GRID® system includes a gauge plate with resettable paddles for multiple activations. It can also be reused on future gauging runs if required.

#### Features and benefits:

- Avoid the added expense and lengthy process of calliper pig runs
- Transmitters can be configured with a pressure switch that activates the system once the pipeline pressure exceeds a set threshold. This allows the system to be installed inside a wet pipeline at atmospheric pressure ahead of the required activation date
- The system is designed to be compatible with pipelines 6 inches in diameter and larger, making it a versatile solution for a wide range of pipeline sizes

## MEG ARTS®

MEG ARTS® is a system with a proven track record in providing highly reliable information on the composition of MEG and other chemicals received subsea during pipeline conditioning operations.

The flowing MEG is analysed for conformity with project purity, dryness or hydrate suppression requirements. Values of density, pressure and temperature are logged and displayed on a high-visibility OLED display. Up to 7 samples are captured for recovery to the surface to confirm composition.



#### Features and benefits

- Pipeline conditioning assured through real-time and logged data and physical sampling
- Can provide a graphical summary of pipeline conditioning operation from downloaded data
- Automatic sampling eliminates the need for a vessel at, or transit to, receipt location resulting in significant savings in vessel time and costs
- Automatic samples can be based on density value or on each selected pig passage when used with a subsea pig signaller
- Optional ROV sampling allows for multiple samples from a single switch meaning the ROV does not need to relocate to different valves
- Samples can be captured from specified train positions
- Removal of industry reliance on theoretical calculations
- Rated to 3000m



# LOOP

## The Versatile Subsea Data Hub

### Sensor Options

- Pressure
- Differential Pressure
- Temperature
- Shock/Vibration
- Chemical Tank Level
- Flow
- Conductivity
- Salinity

Loop is a compact, self-contained subsea data hub designed to provide real-time insights into subsea operations. Capable of integrating up to 12 external sensors, it logs and displays key parameters such as pressure, temperature and flow.

With an optical modem, Loop enables efficient, non-intrusive data retrieval. Collected data is transmitted to the surface, where it is presented in clear, graphical formats for detailed analysis.

Designed for ease of installation, Loop features minimal cabling and connections, reducing operational risk and ensuring dependable performance in subsea environments. Its versatility makes it suitable for a wide range of applications, offering users the flexibility to tailor its capabilities to specific operational needs.

### 6001SD

The 6001SD Temperature and Pressure Subsea Logger is a compact, self-contained, unit which logs and displays readings from internal digital pressure and temperature sensors during the hydrotest. Users can input their own testing parameters and upon meeting your criteria, the unit instantly displays a "PASS" confirmation. This enables operators to make informed decisions without having to recover the unit.



### Features and benefits

- Enables ROV, vessel or diver to perform associated tasks in parallel resulting in accelerated completion of work
- High visibility OLED display
- Can be interfaced with an acoustic alarm, data transducer or strobe for remote confirmation when specific data points are met
- Compact, self-contained with minimal connections and cabling resulting in easy installation
- All functions can be carried out using a single control button and intuitive menu system
- Rated to 3000m



**TRAX**

IK Trax  
Blackburn Business Park, Woodburn Road  
Aberdeen, AB21 0PS  
P: +44 (0)1224 714714  
E: Sales@iktrax.com

## Maximise pipeline performance. Minimise risks.

Ensuring the optimal efficiency of your pipeline operations is our top priority. Our range of intelligent products is perfectly tailored to suit diverse applications onshore, offshore and subsea.

We utilise a variety of technologies to assist our clients throughout the entire life cycle of a pipeline.

We benefit from an in-house R&D team with many years of experience in various disciplines. This gives us the capability to undertake projects incorporating custom designs and the flexibility to modify existing products to suit client and project-specific requirements. To find out more about the complete range of products offered by IK Trax please visit our website or contact us directly to discuss how we can assist.

Intelligent Pipeline Technology



Scan for additional resources and downloads