



TRAX

Intelligent Pipeline
Technology

EMTx40 Operating Manual

Electromagnetic Transmitter

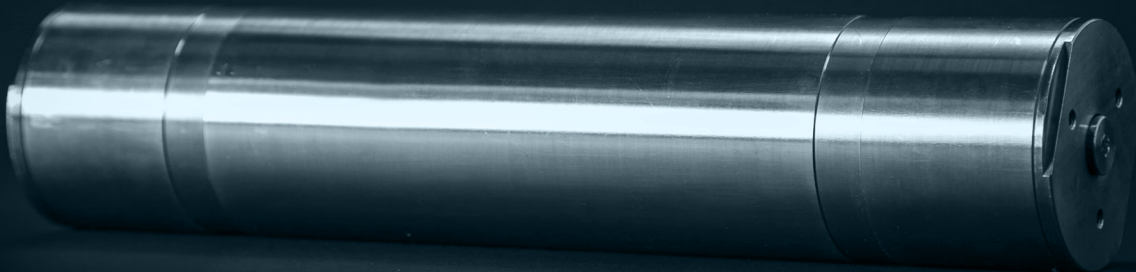

www.iktrax.com



Scan the QR Code for
additional resources
and downloads

CONFIGURATION INFORMATION	
SERIAL NUMBER :	
PRODUCT CODE :	
FREQUENCY :	
RATE 1 PULSE LENGTH :	
RATE 1 REPETITION RATE :	
RATE 1 BATTERY LIFE AT +5°C :	
*RATE 2 PULSE LENGTH :	
*RATE 2 REPETITION RATE :	
*RATE 2 BATTERY LIFE AT +5°C :	
SPECIFIED ON PRESSURE :	
**SPECIFIED OFF PRESSURE :	

*Rate 2 only applicable when the Digital Pressure Switch and Dual Rate Endcap is fitted and the dual rate functionality is required.

**Off pressure only applicable when a Digital Pressure Switch and Dual Rate Endcap is fitted and a non-latching pressure switch is required.

CONTENTS

Page

1.	GENERAL DESCRIPTION	4
1.1.	IK TRAX SHORTCUT	4
1.2.	ENDCAP OPTIONS	4
2.	OPERATION.....	5
2.1.	TOOLKIT	5
2.2.	TURNING ON	5
2.3.	FUNCTION TEST.....	6
2.4.	TURNING OFF	7
3.	STORAGE	7
4.	CONFIGURATION.....	7
4.1.	EMTX CONFIG FOR ANDROID OR WINDOWS	7
4.2.	DEPLOYMENT.....	10
5.	MAINTENANCE.....	11
5.1.	BATTERY REPLACEMENT.....	11
5.2.	O-RING REPLACEMENT	14
5.2.1.	BLEEDSCREW.....	14
5.2.2.	BATTERY / PCB ENDCAP	15
6.	DISPOSAL OF UNIT	16
7.	WARRANTY	17
8.	SAFETY INSTRUCTIONS.....	17
9.	DECLARATION OF CONFORMITY (EU).....	20
10.	DECLARATION OF CONFORMITY (UK).....	21
	APPENDIX A: SPECIFICATIONS	22
	General	22
	ALKALINE BATTERY:	22
	LITHIUM BATTERY:	23
	APPENDIX B OPERATION WARNINGS	24
	APPENDIX C: INSTALLATION.....	25
	APPENDIX D: ADDITIONAL FUNCTIONS.....	26
	PRESSURE SWITCH ENDCAP (NON-CERTIFIED)	26
	DUAL RATE ENDCAP (NON-CERTIFIED)	26
	APPENDIX E: BATTERY LIFE	27

Revision	Updated By	Description of Update	Update Date
A00	RJS	CR01099: Initial release.	09/10/2024
A01	SS	CR24121301 Layout Revision	17/03/2025
A02	SS	CR24121301 Manual refinement	13/04/2025
A03	SS	CR24121301 Battery lifetime tables update	08/05/2025
A04	ADY	CR01099: DPS & DR functionality added	26/03/2026

1. GENERAL DESCRIPTION

The EMTx40 EM Transmitter is an electromagnetic transmitter which can be used for pig tracking and locating functions. The transmitter operates effectively in buried pipelines, pipelines carrying gas or liquid and in pipeline bundles where acoustic transmitters are either less effective or ineffective.

The standard transmission frequency is 22.0Hz, however the frequency is factory and user programmable. An inherent EM null spot is detectable when an EM receiver antenna is at 90 degrees to and pointing towards the centre of the transmitter, allowing for centimetre accurate locating of the pig.

Pigging discs can be fitted directly to the transmitter, meaning the transmitter becomes the pig body. This dramatically increases the received EM signal as it no longer needs to propagate through the pig body in addition to the pipeline

Using the IK Trax EMTx Config application (Windows or Android) the transmitter frequency, power and pulse pattern can be configured to optimise performance and battery life.

The EMTx40 transmitter produces a strong signal which can be detected through even heavy pipeline walls. Received signal strength is dependent on several factors including pipeline diameter, pipeline material, pig design, pig speed, transmitter configuration, receiver equipment and background electromagnetic noise levels. Please contact IK Trax to discuss the most effective transmitter configuration.



1.1. IK TRAX SHORTCUT

IK Trax offers a comprehensive range of resources to support the operation and configuration of the EMTx40 device. To make accessing these materials easier, we've provided a QR code that allows you to instantly connect to our online resource hub using any mobile device. Simply scan the QR code to explore detailed guides, troubleshooting tips, and other essential materials to help you get the most out of your EMTx40.



1.2. ENDCAP OPTIONS

All EMTx40 transmitters come fitted with PCB and Battery Endcaps as standard. The Battery Endcap incorporates a Bleedscrew as standard.

An alternative variant is available that offers a digital pressure switch or dual-rate functionality. Refer to Appendix D for further information.

2. OPERATION

The following instructions are for a unit fitted with the standard BATTERY ENDCAP and PCB Endcap.

⚠ Familiarise yourself with all the rules for the safe operation of this equipment as described in [Appendix B](#).

2.1. TOOLKIT

Below are the required tools to operate the transmitter.



2.0 mm AF Allen Key



ENDCAP REMOVAL TOOL.



5.0 mm AF Allen Key

2.2. TURNING ON

Locate the battery endcap, by finding the battery symbol. Locate the grub screw on top of the endcap that locks the endcap in place. **Do not attempt to remove the battery endcap without having removed the grub screw first, it could cause permanent damage to the device.**



To switch on the transmitter, remove the bleedscrew fully first to free the washer. Then remove the insulating washer and save it for the later use (turning off sequence).

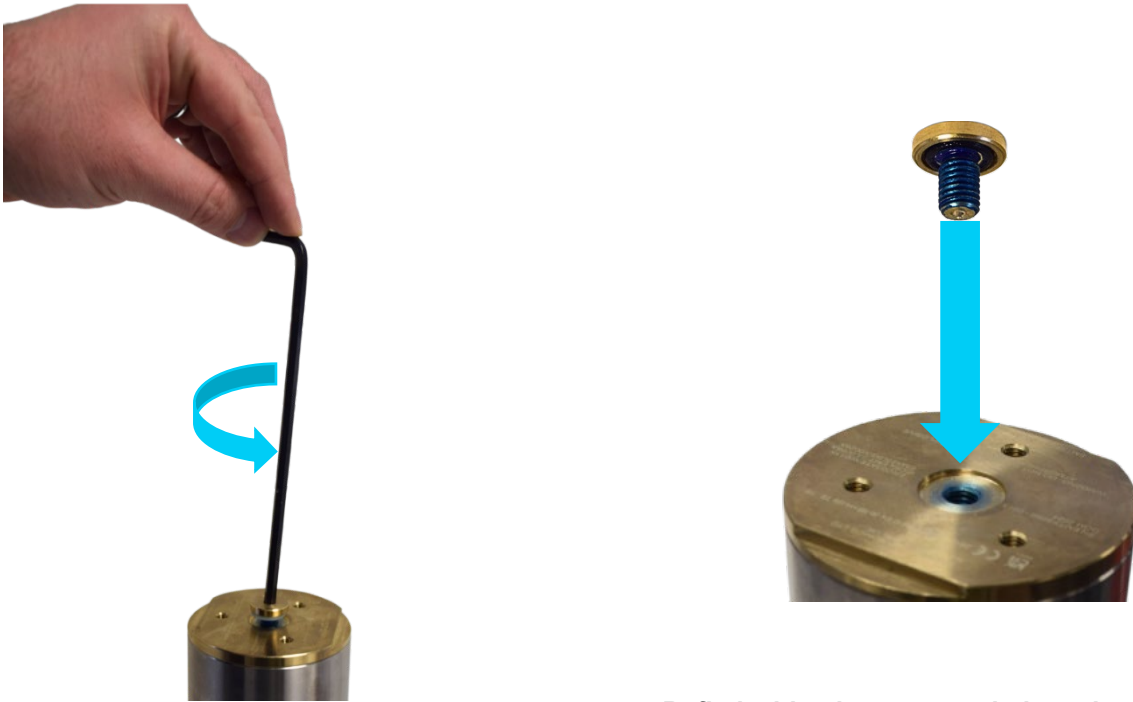

Refit the bleedscrew to switch on the transmitter.

Note: very little torque is required. Damage may occur if over tightened. The transmitter takes approximately 15 seconds to turn on.

2.3. FUNCTION TEST

To receive the signal from the transmitter, an EM receiver is required. For optimal performance, it is recommended to use the IK Trax EMRx receiver. Refer to the EMRx manual for instructions on setup and operation.

1. Place the EMRx receiver antenna approximately 4m away and parallel to the transmitter.

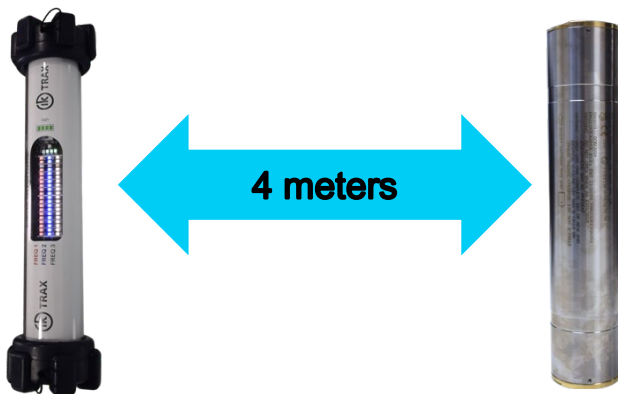

2. Confirm that the received signal frequency and pulse rate are as expected.
3. If all results were as expected, then the system is functional.

2.4. TURNING OFF

1. To turn the transmitter off, use an A/F 5MM Allen key to remove the Bleedscrew to the Battery Endcap. The transmitter should turn off immediately. Replace the insulating washer and insert the Bleedscrew for safe storage.
2. Use an EM receiver such as the IK Trax EMRx to confirm that the transmitter has turned off.

3. STORAGE

If the transmitter is to be placed in storage for a long period of time remove the batteries from the transmitter and store separately.

4. CONFIGURATION

An EM Transmitter has configurable parameters that can be changed via a Bluetooth connection using either the EMTx CONFIG for Windows app or the EMTx CONFIG for Android app. Ensure that the laptop/desktop computer or Android mobile phone/tablet has Bluetooth turned on and that all devices are discoverable. If the laptop/desktop does not have built in Bluetooth, a USB Bluetooth dongle can be used; see the EMTx CONIG manual for more details.

The windows app is available for a download from the company website via this [link](#).

In addition, the following QR code provides quick access to the IK Trax resource hub. It includes shortcuts to manuals, device downloads, and other essential materials.



4.1. EMTX CONFIG FOR ANDROID OR WINDOWS

Launch the Android or Windows app.

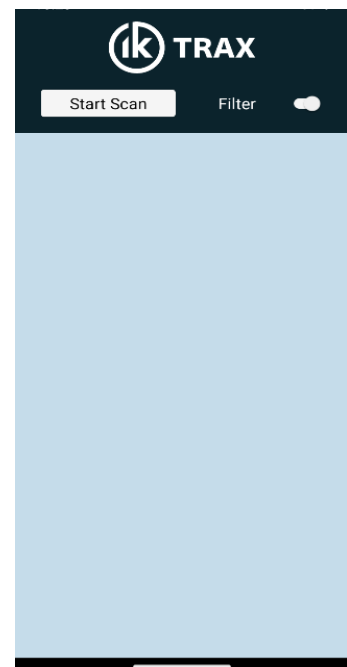
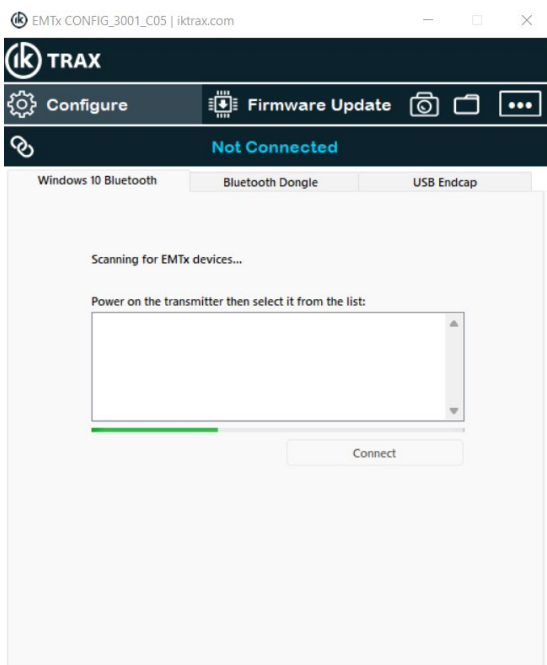

Turn on the transmitter, first locate the bleedscrew on the battery endcap. The BATTERY ENDCAP can be identified by the indicative writing on the housing.

Once the transmitter is switched on, press the 'Start Scan' button in the app. It is not necessary to press anything on Windows app as the scanning happens automatically. The transmitter should then appear in the scanned list. Tap on the device name in the list on Android, or the “Connect” button on Windows to proceed.

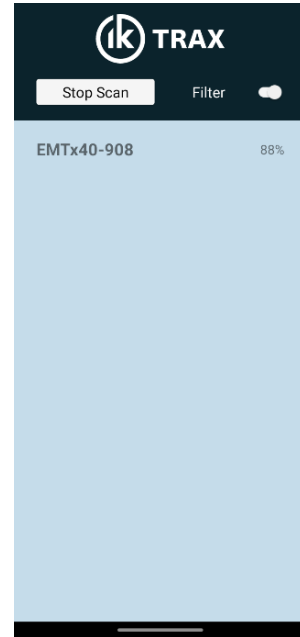
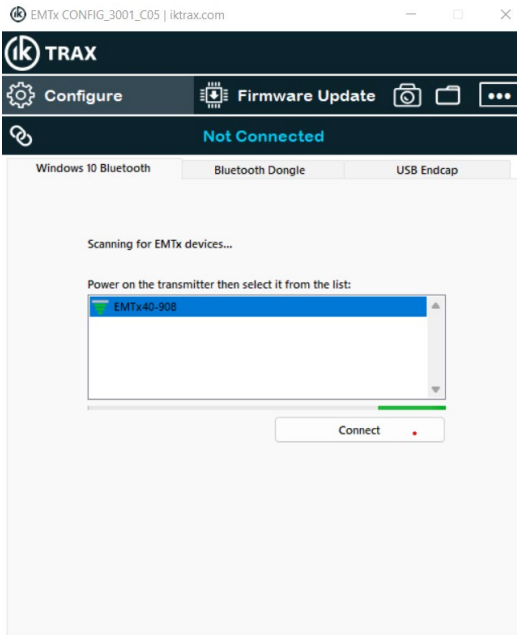

NOTE: The Bluetooth is only discoverable for 15 seconds so be aware that you may have to repeat this process if it doesn't connect.

Once Connected you will be presented with configurational information from the device.

On the windows app proceed to make the required changes, then press “Sync & Disconnect” to send the new configuration to the device, then the app will disconnect.

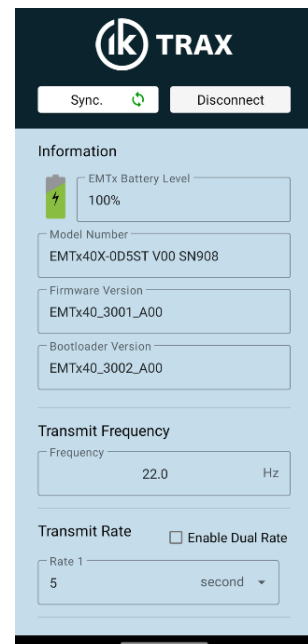
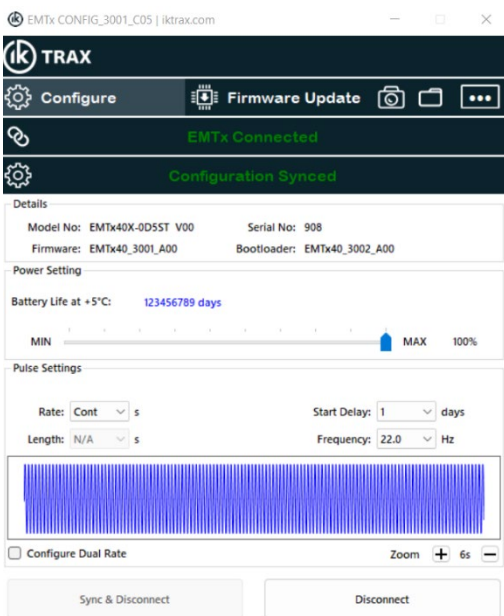

After making any changes to the configuration in the Android app, the “Sync” button will change colour to red. Click it to send the updated configuration to the device. Once the process is complete and the button returns to its original colour, the new configuration has been successfully sent. You can then disconnect from the device by clicking the “Disconnect” button.

Once Disconnected from the transmitter it will start transmitting as per new configuration

4.2. DEPLOYMENT

Before each deployment ensure that the following checks have been completed.

1. Ensure that the transmitter has been installed as detailed in [Appendix C](#).
2. Visually inspect all system components to ensure that they are secure and undamaged.
3. Refer to [Appendix D](#) of this manual for the expected battery lifetime and ensure that it is adequate for the planned operations.
4. Activate the transmitter.
5. Perform a Function Test (page 6).

Remove the BLEEDSCREW from BATTERY ENDCAP using an A/F 5MM Allen key to turn off transmitter. Be cautious of potential trapped pressure in the enclosure.

Locate the locking Grub screw on the side of the transmitter housing.

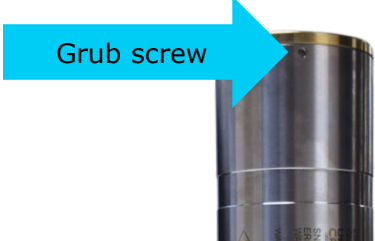

Release BATTERY ENDCAP from the HOUSING by removing grubscrew using an A/F 2MM Allen key.

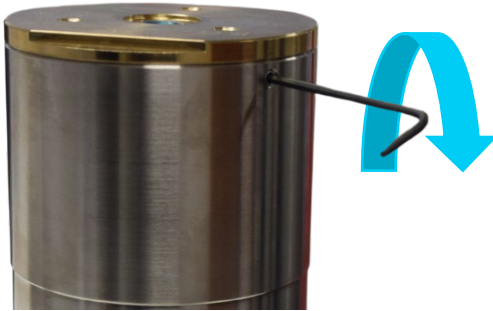

Then using the ENDCAP REMOVAL TOOL supplied, slowly unscrew the BATTERY ENDCAP from the housing.



Examine the O-ring seals for any signs of contamination or damage, replace and/or re-grease if necessary.



Remove the D-CELL batteries from the transmitter by tilting the transmitter such that the D-CELL batteries slide out, preferably onto a surface such as a desk or workbench. Be careful not to drop the D-CELL batteries such that they could injure you. Retain the washers that are placed between the D-CELLS.



Observing correct D-CELL battery orientation as shown above (positive pip facing into the transmitter) insert new D-CELL battery into the transmitter followed by a washer. Repeat with three more D-CELL batteries and washers. Finally insert the final D-CELL battery.

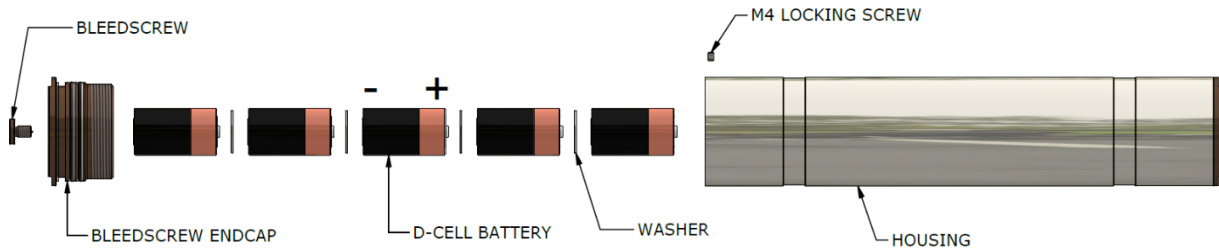

1. Secure the BATTERY ENDCAP to the transmitter with the ENDCAP REMOVAL TOOL and reinsert the grubscrew.
2. Examine the O-ring seal on the BLEEDSCREW for any signs of contamination or damage, replace and/or re-grease if necessary.
3. Install BLEEDSCREW into BATTERY ENDCAP with the insulating washer to secure the BLEEDSCREW. Remove the insulating washer if the transmitter is to be switched on.

5.2. O-RING REPLACEMENT

5.2.1. BLEEDSCREW

Locate the bleedscrew on the battery endcap. The BATTERY ENDCAP can be identified by the indicative writing on the housing.



Using an A/F 5MM Allen key, remove the BLEEDSCREW from the Battery ENDCAP.

Remove the O-ring and clean all sealing surfaces on all parts.

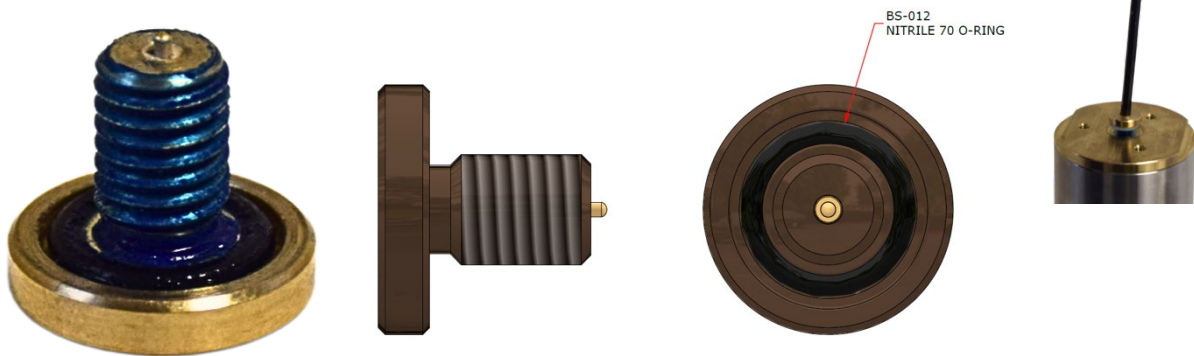

1. Examine all surfaces for signs of corrosion, scoring, and other damage. If there is excessive damage the mechanical parts may need to be replaced.
2. Lightly grease all sealing surfaces and the O-ring with a suitable grease (e.g. DOW CORNING MOLYKOTE 111 COMPOUND) before fitting.
3. Apply a small amount of an oil-based thread lubricant such as "Blue Goop" to the BLEEDSCREW threads. Refer to section 5.1 Step 13 for instruction on installing the BLEEDSCREW.



5.2.2.BATTERY / PCB ENDCAP

Release the BATTERY / PCB ENDCAP from HOUSING by removing grubscrew using an A/F 2MM Allen key.

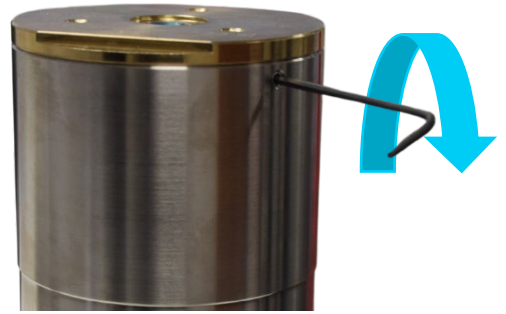

Remove the BATTERY / PCB ENDCAP by unscrewing from the HOUSING using the ENDCAP REMOVAL TOOL.



Referring to the figure below, remove O-rings and Back-up Rings and clean all sealing surfaces on all parts.

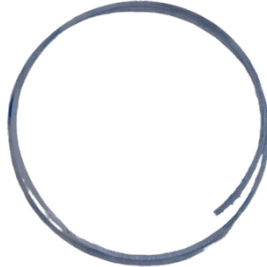
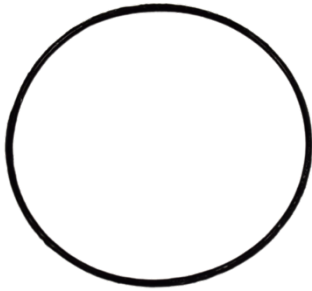

1. Examine all surfaces for signs of corrosion, scoring, and other damage. If there is excessive damage the mechanical parts may need to be replaced.
2. Lightly grease all sealing surfaces and the O-ring and backup ring using a suitable grease (e.g. DOW CORNING MOLYKOTE 111 COMPOUND).



3. Ensure the free space at the tails of the spiral Back-up Rings is filled with grease and then apply a layer of grease over the seams to secure them in place. The spiral tails should not protrude from the assembly.

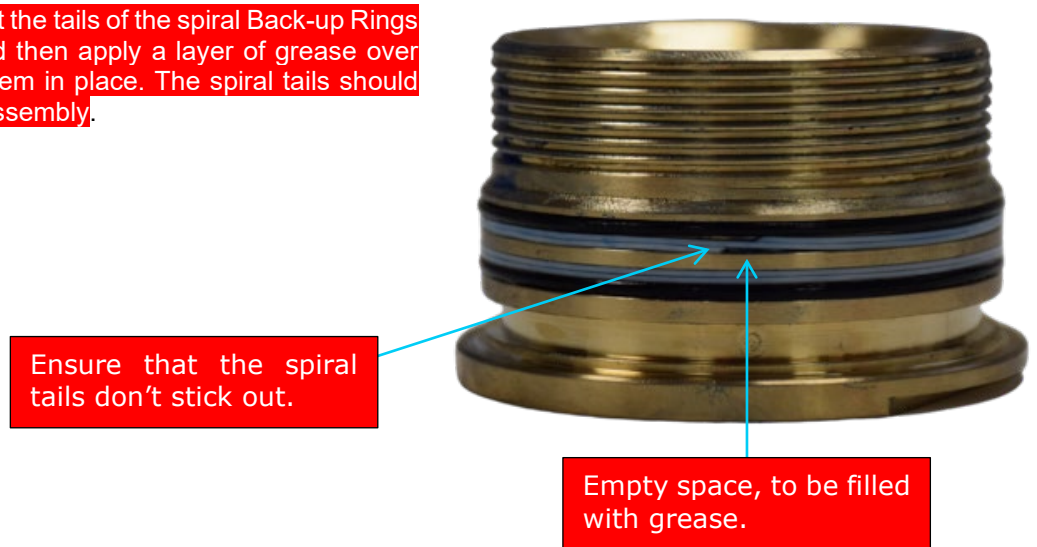

4. Fit the BATTERY / PCB ENDCAP using the ENDCAP REMOVAL TOOL. Secure with the grubscrew.

6. DISPOSAL OF UNIT

IK Trax takes its responsibilities under the WEEE Regulations extremely seriously and has taken steps to be compliant in line with our corporate and social responsibilities. In the UK, IK Trax has joined a registered compliance scheme WeeeCare (registration number **WEE/MP3538PZ/SCH**).

Electrical and electronic equipment should never be disposed of with general waste but must be separately collected for the proper treatment and recovery.

The crossed-out bin symbol, placed on the product, reminds you of the need to dispose of it correctly at the end of its life.

When buying a new product, you will have the possibility to return, free of charge, another end-of-life product of equivalent type that has fulfilled the same functions as the supplied equipment. These items may be deposited at:

Online Electronics Ltd
Doing business as IK Trax
Blackburn Business Park
Woodburn Road
Blackburn
Aberdeen
AB21 0PS
UK

Alternatively, to arrange a collection of any waste electrical equipment, obligated to IK Trax please telephone WeeeCare on **0844 800 2004**.

7. WARRANTY

IK Trax products are guaranteed for one year from the date of purchase. Goods should be returned transportation prepaid to IK Trax.

There is no charge for parts or labour should any product require repair due to a manufacturing deficiency during the guarantee period.

In the event of a manufacturing deficiency the inward transportation costs will be repaid to the client.

8. SAFETY INSTRUCTIONS

SPECIAL CONDITIONS FOR SAFE USE:

1. Only use one complete set of new and identical cells.
2. Only the following permitted batteries shall be used with the corresponding ambient temperature and temperature class.

CELL MANUFACTURER & PART NUMBER	CELL TYPE	CELL VOLTAGE	OPERATING AMBIENT TEMPERATURE	TEMPERATURE CLASS
PROCELL CONSTANT PC1300 (LR20)	Alkaline	1.5V	-20°C to +54°C	T6
ENERGIZER E95	Alkaline	1.5V	-18°C to +55°C	T6
SAFT LS 33600	Lithium	3.6V	-40°C to +85°C	T5

3. The batteries must be installed into the enclosure in accordance with the orientation detailed on the markings.
4. Repair of flame paths is not permitted by the end user.
5. Do not open when an explosive atmosphere may be present.
6. Units must be installed such that ignition sources due to impact and friction sparks are excluded. Assembly of the transmitter into the pig body shall only be performed in a non-hazardous area. Assembly in zone 0, 1 or 2 is not permitted.
7. When required, thread lubricant / grease to be applied to all threads except those of the M4 locking screws. The lubricant / grease shall be of a type that does not harden because of ageing, does not contain an evaporating solvent, and does not cause corrosion of the joint's surfaces, such as Bostik Blue Goop or equivalent.
8. Where used, the bleed screw must be tightened to a torque between 4Nm and 8Nm. Do not exceed 8Nm.
9. Installation shall be carried out in accordance with the relevant, local code of practice for Ex equipment, e.g. EN 60079-14. No additional installation or erection requirements apply.
10. It is the responsibility of the end user to take suitable precautions to prevent exposure to aggressive chemicals that may attack metals or the polymeric materials used in the construction of this equipment, namely:

Nitrile (NBR) O-rings – Susceptible to aromatic hydrocarbons, esters, ketones, and strong oxidisers.

CA104 Aluminium–Bronze Endcaps – Prolonged exposure to ammonia-bearing or sulphide/H₂S environments can cause stress-corrosion.

11. The unit shall only be used within the ambient temperature range, battery types, and operating conditions specified in the ATEX certificate and this instruction manual. No user verifications or tests are required prior to first use. Explosion protection integrity is ensured by the certified design and factory testing.
12. The transmitter may be used in hazardous areas in accordance with its ATEX marking. The applicable temperature class, ambient temperature range, approved battery types, and material limitations are stated in this manual and on the equipment marking. The maximum external pressure rating is 500bar. The maximum surface temperature rise recorded during certification testing was 7.8K.
13. The unit should be cleaned using only a damp cloth.
14. Recalibration is not permitted in the field and shall only be carried out by the manufacturer.
15. Maintenance of explosion-protection-related parts (e.g. enclosure integrity, seals, flamepaths if applicable) shall not be carried out by the user. If damage is suspected, the transmitter shall be returned to the manufacturer (OEL).
16. If the transmitter does not turn on, remove and check batteries only in a non-hazardous area. Replace batteries in accordance with conditions 1-3 and the relevant section of the operating manual. If the fault persists, return the transmitter to the manufacturer (OEL).
17. Only the following serviceable parts may be replaced, and only with parts supplied or approved by the manufacturer (OEL).
 - O-rings (both endcaps)
 - O-ring (bleed screw)
 - Back-up rings (both endcaps)
 - Grub screws
 - Batteries
18. Repairs should be documented with as much information as possible and include as a minimum:
 - Reason for repair (e.g., o-ring perished or damaged)
 - Date of repair
 - Person carrying out repair
 - Parts used
19. Following any repair or maintenance, the unit should be tested in accordance with the relevant section of the operating manual. No verification of explosion protection is required or permitted by the user.
20. The transmitter shall be taken out of service only in a non-hazardous area. The transmitter is switched off by removing the bleed screw. Removal of the bleed screw disconnects the internal power supply and prevents restart. Care shall be taken to vent any residual internal pressure slowly during removal of the bleed screw. Once switched off, the transmitter cannot restart.
21. The transmitter shall only be used within the limits defined by its ATEX certification and this instruction manual. Use outside these limits may compromise explosion safety.
22. Installation, maintenance, and repair of the transmitter shall only be carried out by competent personnel trained in the handling of explosion-protected equipment.
23. The following tools may be required:
 - Allen key suitable for the bleed screw (5.0mm AF)
 - Allen key suitable for the grub screws (2.0mm AF)
 - Manufacturer-supplied endcap removal tool or suitable adjustable spanner.

Tools shall be used in a manner that does not compromise the enclosure or explosion protection.
24. The unit will be etched or engraved as per the below images with the following information:

MMMM	Name and address of Manufacturer
TTTT	Model number of item (endcap or housing)
NNNN	Serial number of the unit
YYYY	Year of Manufacture

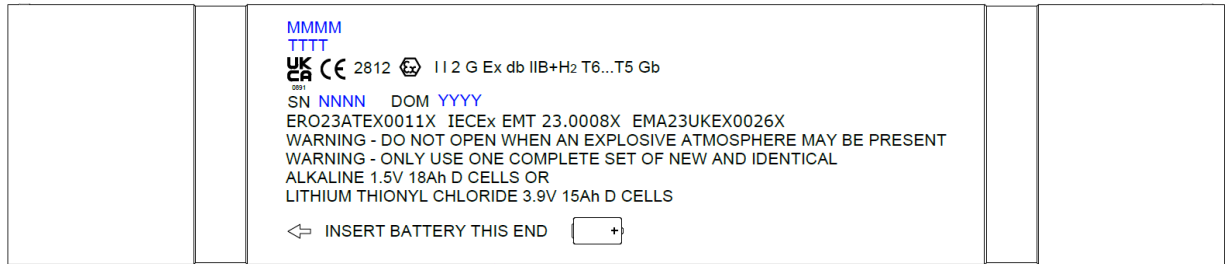

— EMTx40 HOUSING

1. MARKINGS MUST BE ENGRAVED OR ETCHED.
2. **MMMM** SHOWS LATEST NAME AND ADDRESS OF MANUFACTURER AS PER THE CERTIFICATION E.G. ONLINE ELECTRONICS LTD, AB21 0PS, UK.
3. **TTTT** SHOWS THE MODEL NUMBER OF THE HOUSING E.G. EMTx40X-0D5.
4. **NNNN** SUFFIX TO SN SHOWS THE SERIAL NUMBER OF THE UNIT.
5. **YYYY** SUFFIX TO DOM SHOWS THE YEAR OF MANUFACTURE.
6. ADDITIONAL NON-ATEX MARKINGS MAY BE ADDED.

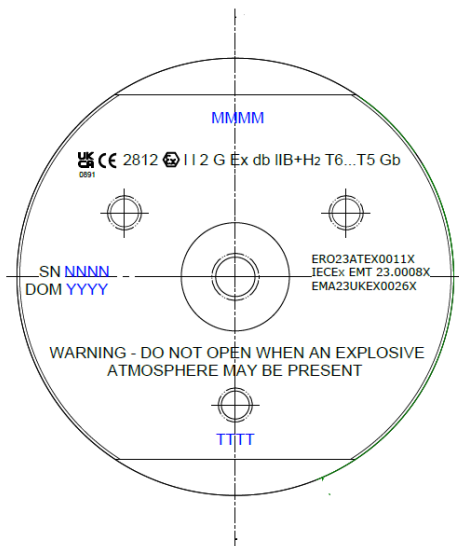

1. MARKINGS MUST BE ENGRAVED OR ETCHED.
2. **MMMM** SHOWS LATEST NAME AND ADDRESS OF MANUFACTURER AS PER THE CERTIFICATION E.G. ONLINE ELECTRONICS LTD, AB21 0PS, UK.
3. **TTTT** SHOWS THE MODEL NUMBER OF THE ENDCAP E.G. EMTx40X-ES0.
4. **NNNN** SUFFIX TO SN SHOWS THE SERIAL NUMBER OF THE UNIT.
5. **YYYY** SUFFIX TO DOM SHOWS THE YEAR OF MANUFACTURE.
6. ADDITIONAL NON-ATEX MARKINGS MAY BE ADDED.

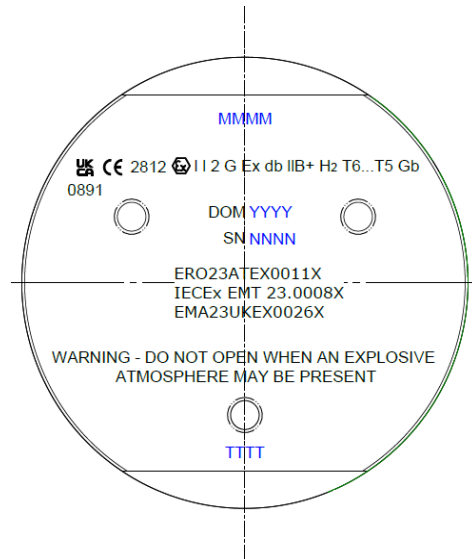

1. MARKINGS MUST BE ENGRAVED OR ETCHED.
2. **MMMM** SHOWS LATEST NAME AND ADDRESS OF MANUFACTURER AS PER THE CERTIFICATION E.G. ONLINE ELECTRONICS LTD, AB21 0PS, UK.
3. **TTTT** SHOWS THE MODEL NUMBER OF THE ENDCAP E.G. EMTx40X-ES0.
4. **NNNN** SUFFIX TO SN SHOWS THE SERIAL NUMBER OF THE UNIT.
5. **YYYY** SUFFIX TO DOM SHOWS THE YEAR OF MANUFACTURE.
6. ADDITIONAL NON-ATEX MARKINGS MAY BE ADDED.

The manufacturer's address:

Online Electronics Ltd
 Online House
 Blackburn Business Park
 Woodburn Road
 Blackburn
 Aberdeen
 AB21 0PS
 UNITED KINGDOM

9. DECLARATION OF CONFORMITY (EU)

This declaration of conformity is issued under the sole responsibility of the manufacturer:

Online Electronics Ltd
Online House
Blackburn Business Park
Woodburn Road
Blackburn
Aberdeen
AB21 0PS
UNITED KINGDOM

Object of declaration:

EMTx_40X range of electromagnetic transmitters

With the following markings:

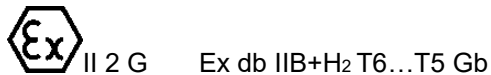

The object of the declaration described above is in conformity with the relevant Union harmonization legislation:

ATEX: ATEX Directive 2014/34/EU
EMC: EMC Directive 2014/30/EU

The following standard(s) and technical specification(s) have been applied:

ATEX: EN IEC 60079-0:2018
EN 60079-1:2014

UKEx: EN IEC 60079-0:2018
EN 60079-1:2014

IECEX: IEC 60079-0:2017
IEC 60079-1:2014

EMC: EN61000-6-4:2007
EN61000-6-2:2005

As per the certificate(s) below:

ATEX: EU Type Examination Certificate ERO23ATEX0011X issued by Element Rotterdam BV, Notified Body 2812, under GB/TRC/QAR11.0002/10. Refer to Special Conditions of Safe Use within ERO23ATEX0011X.

UKEx: UK Type Examination Certificate EMA23UKEX0026X issued by Element Skelmersdale UK, Approved Body 0891, under EMA21UKQAN0017 R04. Refer to Special Conditions of Safe Use within EMA23UKEX0026X.

IECEX: IECEX Certificate of Conformity IECEX EMT 23.0008X issued by Element Materials Technology under GB/TRC/QAR11.0002/10. Refer to Conditions of Certification within IECEX EMT 23.0008X.

The apparatus named above has been designed to comply with the relevant sections of the above referenced specifications and complies with all essential requirements of the Directives and Systems.

10. DECLARATION OF CONFORMITY (UK)

This declaration of conformity is issued under the sole responsibility of the manufacturer:

Online Electronics Ltd
Online House
Blackburn Business Park
Woodburn Road
Blackburn
Aberdeen
AB21 0PS
UNITED KINGDOM

Object of declaration:

EMTx_40X range of electromagnetic transmitters

With the following markings:

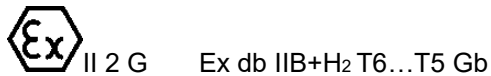

The object of the declaration described above is in conformity with the relevant Union harmonization legislation:

UKEx: Equipment and Protective Systems Intended for Use in Potentially Explosive Atmospheres UKSI 2016:1107
EMC: EMC Directive 2014/30/EU

The following standard(s) and technical specification(s) have been applied:

ATEX: EN IEC 60079-0:2018
EN 60079-1:2014
UKEx: EN IEC 60079-0:2018
EN 60079-1:2014
IECEX: IEC 60079-0:2017
IEC 60079-1:2014
EMC: EN61000-6-4:2007
EN61000-6-2:2005

As per the certificate(s) below:

ATEX: EU Type Examination Certificate ERO23ATEX0011X issued by Element Rotterdam BV, Notified Body 2812, under GB/TRC/QAR11.0002/10. Refer to Special Conditions of Safe Use within ERO23ATEX0011X.
UKEx: UK Type Examination Certificate EMA23UKEX0026X issued by Element Skelmersdale UK, Approved Body 0891, under EMA21UKQAN0017 R04. Refer to Special Conditions of Safe Use within EMA23UKEX0026X.
IECEX: IECEX Certificate of Conformity IECEX EMT 23.0008X issued by Element Materials Technology under GB/TRC/QAR11.0002/10. Refer to Conditions of Certification within IECEX EMT 23.0008X.

The apparatus named above has been designed to comply with the relevant sections of the above referenced specifications and complies with all essential requirements of the Directives and Systems.

APPENDIX A: SPECIFICATIONS

NOTE: THE SPECIFICATIONS BELOW ARE VALID FOR THE STANDARD CONFIGURATION ONLY. REFER TO PAGE 1 OF THIS MANUAL FOR THE CONFIGURATION INFORMATION SPECIFIC TO THE TRANSMITTER BEING USED.

GENERAL

Bump rating 20G

Housing material ASTM B348 Grade 5 Titanium Ti-6Al-4V

Endcap material Alloy Bronze CA 104 EN 12163

O-ring material NBR70

Transmitter weight in (including batteries) 7kg (15.5lbs)

External pressure rating 500bar (7252psi)

Length 374mm (14.7")

Diameter 76.8mm (3.02")

Frequency adjustable 10Hz to 30Hz in 0.1Hz increments

Power adjustable 10% to 100% in 10% increments

Pulse length adjustable 0.3 second to 1.0 second in 0.1 second increments

Pulse rate adjustable 1 second to 10 seconds in 1 second increments

ATEX/IECEX/UKEx code Ex db IIb+H2 T6..T5 Gb

EU Type Examination Certificate Number ERO23ATEX0011X

UK Type Examination Certificate Number EMA23UKEX0026X

IECEX Certificate Number IECEX EMT 23.0008X

ALKALINE BATTERY:

Battery Type Alkaline D Cell Pack

Lifetime in other configurations See [Appendix D Battery Life](#)

Temperature range (alkaline) -20°C to + 50°C (-4°F to + 122°F)

EMTx40 predicted lifetimes (days), 0.4s pulse length, +5°C						
Power Setting	Cont.	1 sec	2 sec	3 sec	4 sec	5 sec
100%	2.7	6	11.1	15.7	19.9	23.5

LITHIUM BATTERY:

Battery Type.....Alkaline D Cell Pack

Lifetime in other configurations..... See Appendix D Battery Life

Temperature range (lithium).....-40°C to + 80°C (-40°F to + 176°F)

EMTx40 predicted lifetimes (days), 0.4s pulse length, +5°C						
Power Setting	Cont.	1 sec	2 sec	3 sec	4 sec	5 sec
100%	4	9	16.7	23.6	29.9	35.3

APPENDIX B OPERATION WARNINGS

⚠ WARNING: The Special Conditions for Safe Use as detailed in section 9 must be followed at all times.

⚠ WARNING: Any operation involving pressure is potentially hazardous. No person should use this equipment unless they are fully aware of the potential hazards of working with pressurised vessels. The purchaser of this equipment is responsible for the training and competence of operators and the manner in which it is used. This manual should be read through and understood before installation and commissioning so that the operator is familiar with the equipment. Contact IK Trax immediately should any difficulty arise in the use of this equipment.

⚠ WARNING: DO NOT open when an explosive atmosphere may be present. Always use caution when opening equipment which has been in a pressurised environment. It is possible for pressure to leak into the equipment and remain there even after external pressure has been removed. ALWAYS point the end to be opened towards a safe area and away from yourself or others. Contact IK Trax immediately if there is a suspicion that the equipment has become pressurised.

⚠ WARNING: USE ONLY approved D Cell batteries. ALWAYS observe correct battery polarity. New batteries should be installed before each deployment.

⚠ WARNING: Do not expose to aggressive solvents or chemicals which could be harmful to the HOUSING, O-RINGS, CONNECTORS or any other parts of the equipment.

⚠ CAUTION: This equipment should only be opened in a clean laboratory environment.

⚠ CAUTION: To prevent the formation of condensation within the transmitter, allow the transmitter temperature to stabilise within the laboratory environment for a minimum of 6 hours prior to opening.

⚠ CAUTION: It is possible for liquids to become trapped in threads and/or gaps around openings. ALWAYS point the end to be opened downwards to allow any trapped liquid to drain out of and not into the equipment.

APPENDIX C: INSTALLATION

⚠ WARNING: The Special Conditions for Safe Use as detailed in SECTION 9 must be always followed.

⚠ WARNING: The transmitter must be mounted in such a way that no movement or vibration is possible whatsoever (e.g. clamped). If the transmitter is allowed to rattle and/or vibrate within the pig then the resultant hammering effect can exceed the bump rating of the transmitter leading to damage and/or failure. This is particularly important in gas pipelines.

⚠ CAUTION: All EM transmitters will induce electrical currents in any conductive materials closely surrounding them which can result in a severe reduction in signal strength and/or battery lifetime. This effect can be minimised by reducing the amount of conducting material surrounding the transmitter and leaving as much of the transmitter exposed as possible. Any slits or apertures which can be made in the surrounding material will help. Use materials with as high resistance as possible. Non-conducting materials such as plastics will not suffer from this effect. EM transmitters must not be surrounded by low resistance metals such as aluminium (including tubes or mounting clamps) under any circumstances.

⚠ CAUTION: Any magnetic material surrounding the transmitter will tend to block the EM signal from the transmitter and reduce the received signal strength outside the pipeline. This effect can be minimised by reducing the amount of magnetic material surrounding the transmitter and leaving as much of the transmitter exposed as possible. Any slits or apertures which can be made in the surrounding material will help. Use materials with as low magnetic permeability as possible. Non-magnetic materials such as plastics will not suffer from this effect. The table below shows the typical characteristics of several potential pig and mounting materials with the best choice at the top, and the worst choice at the bottom. 316 stainless steel provides a good balance of properties and cost. An aluminium alloy would be a very poor choice because of the very low resistivity and should not be used under any circumstances.

MATERIAL	RESISTIVITY ($\mu\Omega.m$)	MAGNETIC PERMEABILITY
PLASTIC	∞	1.000
316 STAINLESS STEEL	0.75	1.008
2205 DUPLEX SS	0.80	>25.0
1005 STEEL	0.20	>100
ALUMINIUM ALLOYS	0.04	1.000

For optimum performance the transmitter should be clamped inside a plastic pig body. An alternative mounting arrangement is shown below. It uses several lengths of threaded studding to clamp the transmitter between two plates. The advantage of this arrangement is that it has limited amounts of metal around the transmitter and will therefore have limited effect on the transmitter performance. Please contact IKTRAX for further information and guidelines regarding EM transmitter mounting and installation.

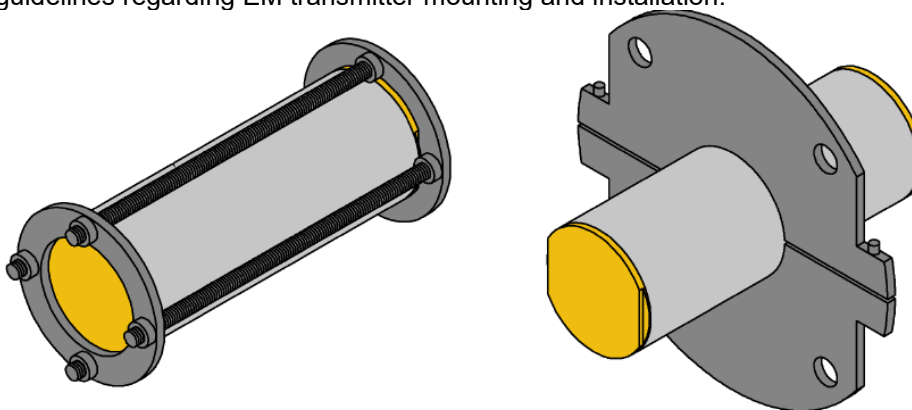

⚠ CAUTION: In extreme circumstances strong magnets in close proximity to EM transmitters may dramatically impact signal and lifetime. Where possible maintain a separation of at least 200mm between the EM transmitter and any magnets.

APPENDIX D: ADDITIONAL FUNCTIONS

DIGITAL PRESSURE SWITCH and/or DUAL RATE ENDCAP (NON-CERTIFIED)

The EMTx40 Digital Pressure Switch (DPS) and Dual Rate (DR) Endcap is a non-ATEX/IECEX-certified endcap designed to replace the standard PCB endcap. It can have either or both options fitted.

⚠ WARNING: If this Endcap is fitted to an ATEX/IECEX certified transmitter body, the transmitter must **not** be used in an ATEX/IECEX only environment.

This Endcap variant is supplied fully assembled and is not interchangeable with the standard EMTx40 version.

PRESSURE SWITCH ENDCAP (NON-CERTIFIED)

When the digital pressure switch activation is ENABLED and the ON pressure is set, the unit activates when external pressure exceeds the pre-configured ON pressure.

Transmitters configured, using the software apps, as a NON-LATCHING pressure switch will stop transmitting when external pressure drops below the ON pressure minus the dead band. In contrast, transmitters as a LATCHING pressure switch will continue transmitting until the batteries are depleted or the Bleedscrew is removed.

DUAL RATE ENDCAP (NON-CERTIFIED)

When dual rate functionality is required, the unit allows external equipment (e.g., an IK Trax 7000 ARGF) to switch it between two pre-configured pulse rates.

Transmitters configured with LATCHING dual rate functionality operate as non-latching units, except that the unit will permanently switch from pulse rate 2 to pulse rate 1 when an open circuit is detected between pins 1 and 2 on the IE55 connector.

Each of these Endcap variants are supplied fully assembled and are not interchangeable with the standard EMTx40 version.

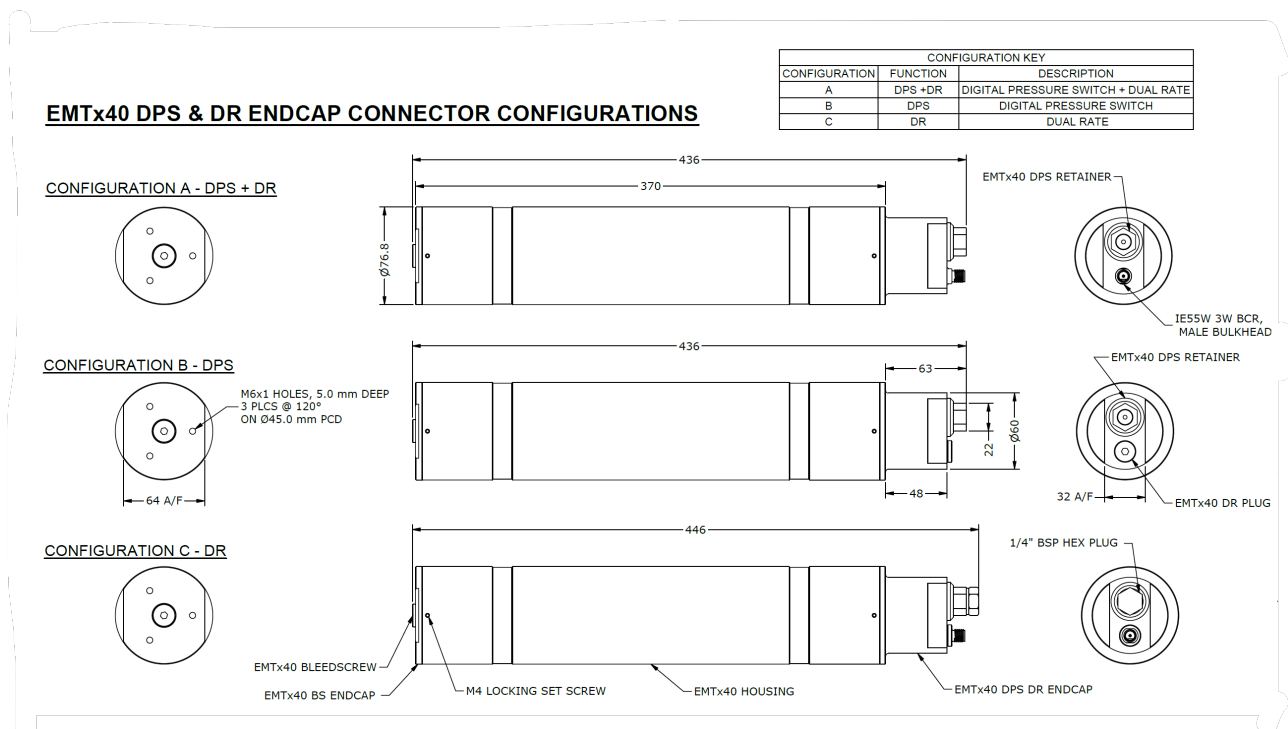

APPENDIX E: BATTERY LIFE

The operating temperature at which the transmitter is used alters the operating lifetime with colder temperatures typically shortening achievable lifetime.

Transmitter frequency affects lifetime because pulse lengths are restricted to a whole number of cycles of the transmitter frequency. The lifetimes stated in this manual are all at 22.0Hz unless stated otherwise and will not vary by more than 10% at other frequencies. The EMTx Config Windows and Android applications include the effects of frequency in their lifetime predictions.

In extreme circumstances the transmitter operating lifetime may be reduced by how the transmitter is installed on a pig. Refer to [Appendix C](#) within this manual for tips on how to achieve optimum performance from the transmitter with regards to the mounting arrangement.

The tables below show predicted lifetimes for a range of configurations. The mVpp values show the predicted signal received in open air at 1m with IK Trax reference antenna.

Please contact IK Trax to discuss any project specific requirements.

EMTx40 predicted lifetimes (days), 0.4s pulse length, +5°C - ALKALINE						
Power Setting	Cont.	1 sec	2 sec	3 sec	4 sec	5 sec
100% (650mVpp)	2.7	6	11.1	15.7	19.9	23.5
50% (433mVpp)	5.4	12	22.2	31.5	39.8	47
20% (260mVpp)	13.5	30	55.6	78.7	99.4	117.6

EMTx40 predicted lifetimes (days), 0.4s pulse length, +20°C - ALKALINE						
Power Setting	Cont.	1 sec	2 sec	3 sec	4 sec	5 sec
100% (650mVpp)	3.4	7.5	13.9	19.6	24.9	29.4
50% (433mVpp)	6.8	15	27.8	39.4	49.8	58.8
20% (260mVpp)	16.9	37.5	69.5	98.4	124.3	147

EMTx40 predicted lifetimes (days), 0.4s pulse length, +5°C - LITHIUM						
Power Setting	Cont.	1 sec	2 sec	3 sec	4 sec	5 sec
100% (650mVpp)	4	9	16.7	23.6	29.9	35.5
50% (433mVpp)	8	18	33.3	47.3	59.7	70.5
20% (260mVpp)	20	45	83.4	118	149.1	176.4

EMTx40 predicted lifetimes (days), 0.4s pulse length, +20°C - LITHIUM						
Power Setting	Cont.	1 sec	2 sec	3 sec	4 sec	5 sec
100% (650mVpp)	5	11.3	20.9	29.5	37.4	44.1
50% (433mVpp)	10	22.5	41.6	59.1	74.6	88.1
20% (260mVpp)	25	56.3	104.3	147.5	186.4	220.5